

PPU WENDEPLATTEN + VORTEX BAR

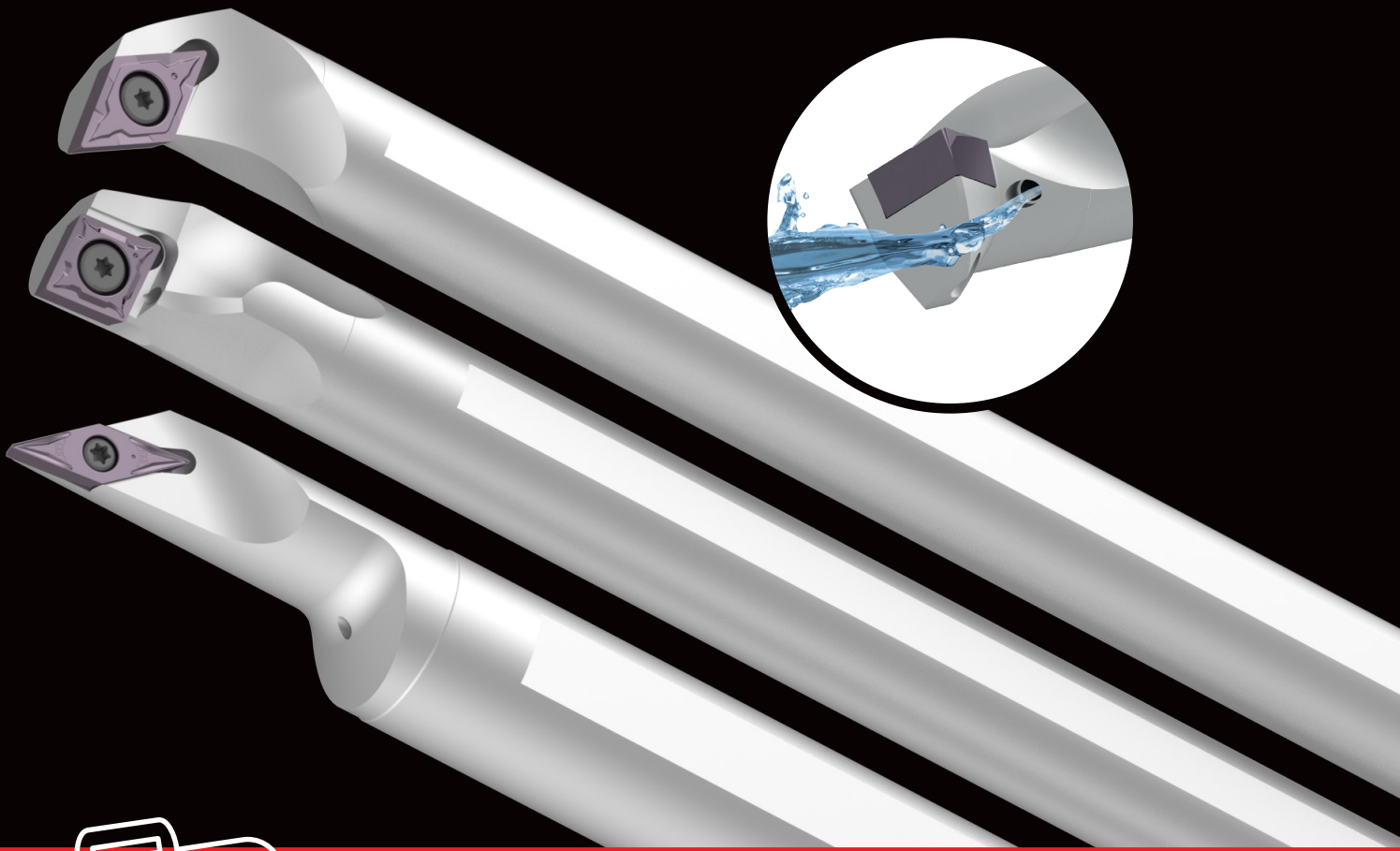

SPECIAL
KIT Action

PPU-Wendeplatten mit Vortex Bar - Sonderstahl Borstangen
Ihr Lösungspaket für das Präzisionsausdrehen auch bei
Schlichtbearbeitung bei unterbrochenem Schnitt und
Ausdrehen geringer Wandstärken.

nikkoTOOLS
SORMA CUTTING SOLUTIONS

PPU WENDEPLATTEN + VORTEX BAR











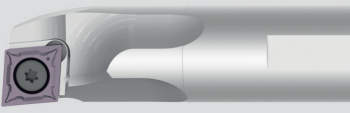

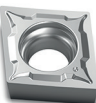
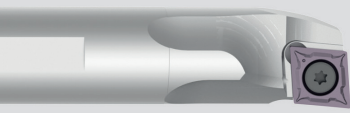
nikkoTOOLS
SORMA CUTTING SOLUTIONS

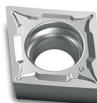
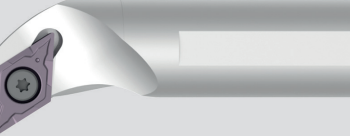
**SPECIAL
KIT**

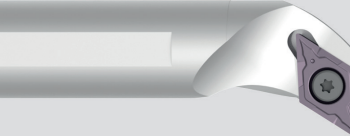

Testen Sie Vortex Bar + PPU Einsätzen!

Jedes Kit besteht aus 4 Vortex Bars und 10 PPU Wendepplatten

<h1>R</h1>   <p>DMIN</p>	1 x NT-V10K-SCLCR06-12 (Ø10)	<p>INTERNAL COOLANT</p> 	12
	1 x NT-V12M-SCLCR06-14 (Ø12)		14
	1 x NT-V16Q-SCLCR09-18 (Ø16)		18
	1 x NT-V20R-SCLCR09-22 (Ø20)		22
	 <p>5 x CCGT060204-PPU 5 x CCGT09T304-PPU</p> <p>JP5125 U-VORTEX-CC01R</p>		
<h1>L</h1>   <p>DMIN</p>	1 x NT-V10K-SCLCL06-12 (Ø10)	<p>INTERNAL COOLANT</p> 	12
	1 x NT-V12M-SCLCL06-14 (Ø12)		14
	1 x NT-V16Q-SCLCL09-18 (Ø16)		18
	1 x NT-V20R-SCLCL09-22 (Ø20)		22
	 <p>5 x CCGT060204-PPU 5 x CCGT09T304-PPU</p> <p>JP5125 U-VORTEX-CC01L</p>		
<h1>R</h1>   <p>DMIN</p>	1 x NT-V10K-SDUCR07-14 (Ø10)	<p>INTERNAL COOLANT</p> 	14
	1 x NT-V12M-SDUCR07-16 (Ø12)		16
	1 x NT-V16Q-SDUCR11-23 (Ø16)		23
	1 x NT-V20R-SDUCR11-27 (Ø20)		27
	 <p>5 x DCGT070204-PPU 5 x DCGT11T304-PPU</p> <p>JP5125 U-VORTEX-DC01R</p>		
<h1>L</h1>   <p>DMIN</p>	1 x NT-V10K-SDUCL07-14 (Ø10)	<p>INTERNAL COOLANT</p> 	14
	1 x NT-V12M-SDUCL07-16 (Ø12)		16
	1 x NT-V16Q-SDUCL11-23 (Ø16)		23
	1 x NT-V20R-SDUCL11-27 (Ø20)		27
	 <p>5 x DCGT070204-PPU 5 x DCGT11T304-PPU</p> <p>JP5125 U-VORTEX-DC01L</p>		

PPU WENDEPLATTEN + VORTEX BAR



nikkoTOOLS
SORMA CUTTING SOLUTIONS



239,00
Euro



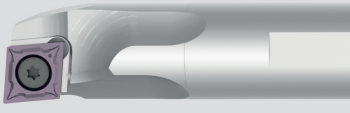

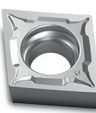
Testen Sie Vortex Bar + PPU Einsätze!

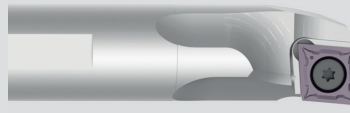

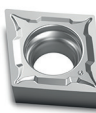
Jedes Kit besteht aus 3 Vortex Bars und 10 PPU Wendepplatten

R						
			INTERNAL COOLANT			DMIN
1 x NT-V08H-SCLCR06-10 (Ø8)				10		
1 x NT-V10K-SCLCR06-12 (Ø10)				12		
1 x NT-V12M-SCLCR06-14 (Ø12)				14		
	5 x CCGT060204-PPU	JP5125		U-VORTEX-3CCR		

L						
			INTERNAL COOLANT			DMIN
1 x NT-V08H-SCLCL06-10 (Ø8)				10		
1 x NT-V10K-SCLCL06-12 (Ø10)				12		
1 x NT-V12M-SCLCL06-14 (Ø12)				14		
	5 x CCGT060204-PPU	JP5125		U-VORTEX-3CCL		

Jedes Kit besteht aus 2 Vortex Bars und 10 PPU Wendepplatten

R						
			INTERNAL COOLANT			DMIN
1 x NT-V20R-SVJBR11-25 (Ø20)				25		
1 x NT-V25S-SVJBR11-30 (Ø25)				30		
	10 x VCGT110304-PPU	JP5125		U-VORTEX-VC01R		

L						
			INTERNAL COOLANT			DMIN
1 x NT-V20R-SVJBL11-25 (Ø20)				25		
1 x NT-V25S-SVJBL11-30 (Ø25)				30		
	10 x VCGT110304-PPU	JP5125		U-VORTEX-VC01L		

Warum sollten Sie Vortex Bar testen?

- Verbesserter Spanauswurf durch das spezielle Spanraumdesign
- Hochwertiger Sonderstahl reduziert Vibrationen selbst bei großem Überhang (max. 5XD)
- Interne Kühlmittelkanäle im gesamten Sortiment

Warum sollten Sie PPU Einsätze testen?

- Reduzierte Vibrationen bei Ausdreheroperationen ohne Abdrengung der Teile, dank der robusten und zuverlässigen Geometrie die eine geringe Schnittkraft benötigt
- Hitzebeständiges Substrat für hohe Standzeiten, die speziell für Edelstahl und Superlegierungen geeignet sind
- Dank der optimierten Schnittgeometrie können auch große Herausforderungen gemeistert werden, wie beispielsweise das Ausdrehen geringer Wandstärken
- Universelle Lösung, geeignet für schwierige Anwendungen bis hin zur konventionellen Bearbeitung



Via Don F. Tosatto, 8
30174 Mestre - Venezia
+39 041.959179
info@nikkotools.com

www.nikkotools.com

