

+ 5%

Teuerungszuschlag

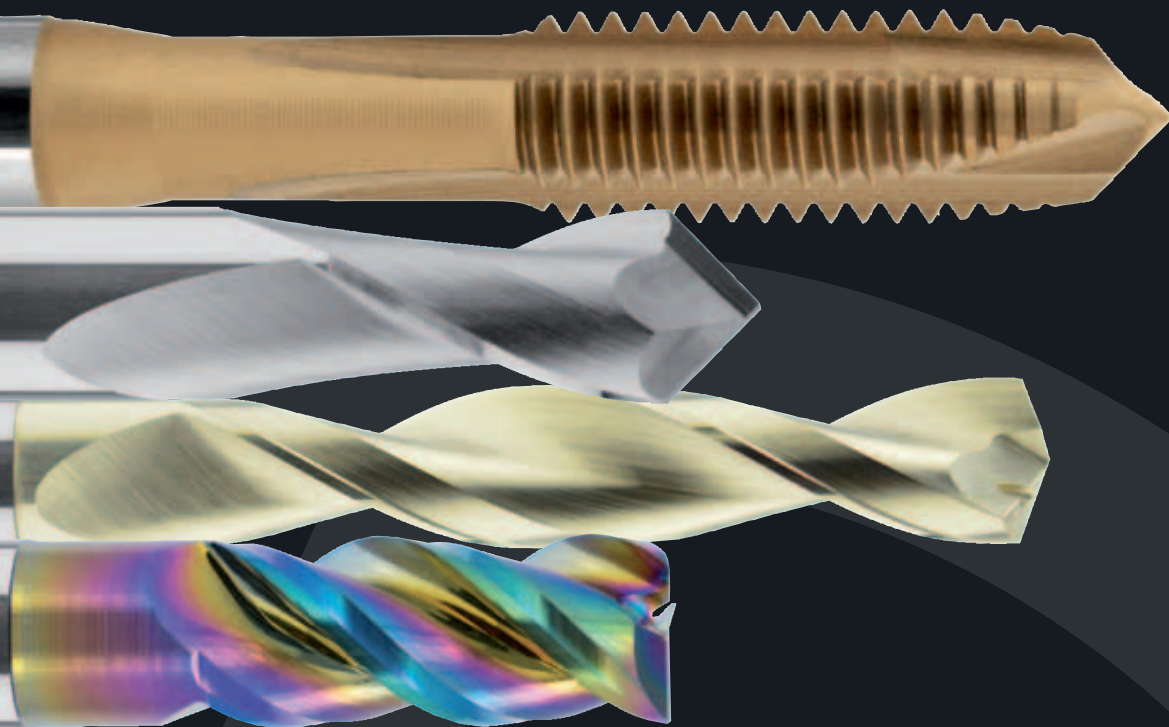

HALLAS
TOOLS

TOPSELLER

AUF EIN WORT

Man meistert seine Zukunft mit den Erfahrungen der Vergangenheit.

Dieser Sinnspruch ist mir Grundsatz und Motivation zugleich. Seit vielen Jahren in der Werkzeugbranche tätig, konnte ich einen reichen Schatz an Erfahrungen sammeln – einen Schatz, den nun Hallas Tools zum Vorteil seiner Kundinnen und Kunden nutzt!

In den ersten zweieinhalb Jahrzehnten meiner Berufstätigkeit durfte ich als Führungskraft unter anderem einen wesentlichen Beitrag dazu leisten, einen kleinen Handelsbetrieb zu einem international anerkannten Werkzeughersteller auf- und auszubauen. Ob Werkzeugentwicklung, Prozessoptimierung, Werkzeugpräsentation oder die Begleitung von in- und ausländischen Vertriebspartnern bei der Markteinführung mit Produktschulung und technischem Support – das Aufgabenspektrum war ebenso fordernd wie abwechslungsreich. Mit all diesen wertvollen Erfahrungen im Gepäck machte ich mich Anfang 2022 auf, um mit einem jungen, engagierten Team unter der Marke Hallas Tools als innovativer Anbieter hochwertiger Standard- und Sonderwerkzeuge neu durchzustarten.

Unser Anspruch ist klar definiert – und hochgesteckt: Wir bieten Ihnen einen Mehrwert, der Seinesgleichen sucht.

Konkret bedeutet dies: Wir helfen Ihnen, Ihre Prozesse zu optimieren und damit Kosten zu sparen. Denn wir liefern einzigartige Produkt- und Dienstleistungsqualität, die dank eines optimalen Preis-Leistungsverhältnisses schnelle Entscheidungen ermöglicht. Weitreichende Flexibilität und absolute Zuverlässigkeit sind für uns ebenso selbstverständlich, wie eine engagierte persönliche Betreuung, die auch das scheinbar Unmögliche möglich macht. Darüber hinaus bietet Hallas Tools einen hochqualifizierten technischen Support, der Ihnen jederzeit mit



Rat und Tat zur Seite steht. Und last but not least können wir auch bei der Verfügbarkeit unserer Produkte punkten. So sind bei Hallas Tools z.B. sogar VHM-Sonderwerkzeuge inklusive Beschichtung innerhalb von fünf bis acht Werktagen lieferbar.

Zögern Sie also nicht und geben Sie uns die Chance, unsere Erfahrung und unser Know-how unter Beweis zu stellen. Sie werden sehen, es zahlt sich aus! Denn wir setzen alles daran, Sie nicht nur zufrieden zu stellen, sondern rundum zu begeistern.

In diesem Sinne: Auf bald bei Hallas Tools!

Ihr
Markus Hallas
mit dem Team der Hallas Tools GmbH





Allgemeine Hinweise:

Der Topsellerkatalog ist ab dem 01. Januar 2024 gültig.

**Alle Preise sind unverbindliche Preisempfehlungen
zuzüglich Mehrwertsteuer.**

**Mögliche Druckfehler aller Art bei technischen Daten
oder Preisen berechtigen nicht zu Forderungen.**

**Maß- bzw. Preisänderungen im Zuge von einer Weiterentwicklung
oder einer Normänderung behalten wir uns vor.**

**Die angegebenen Schnittdaten sind Richtwerte.
Die tatsächlichen Schnittgeschwindigkeiten und Vorschübe
sind von der jeweiligen Arbeitsbedingung abhängig.**



MATERIALGRUPPEN

MATERIALBESCHREIBUNG

BEISPIELE

P.1	allg. Stähle/general steels <500 N/mm	10037 (St37-2) 1.0044 (St44-2) 1.5419 (GS-22M04) 1.1014 (R-Fe80)
P.2	allg. Stähle/general steels <650 N/mm	1.0570 (St52-3) 1.0970 (QStE260N) 1.0726 (35520) 1.7337 (16CrMo4-4)
P.3	allg. Stähle/general steels <800 N/mm	1.0060 (St60-2) 1.0715 (9SMn28) 1.6587 (17CrNiMo6) 1.0482 (19Mns)
P.4	allg. Stähle/general steels <1000 N/mm	1.0728 (60S20) 1.0727 (46S20) 1.0757 (46SP620) 1.8070 (21CrMoVS11)
P.5	allg. Stähle/general steels <1400 N/mm	1.2311 (40CRMnMo7) 1.2344 (X40CRM0V5-1) 1.3343 (S6-5-2) 1.8550 (34CrAlNi7)
P.6	Einsatzstähle/case hardening steels <1000 N/mm	1.0301 (C10) 1.7131 (16MnCr5) 1.5752 (14NiCr14) 1.1141 (Ck15)
P.7	Nitrierstähle/nitriding steels <1000 N/mm	1.8504 (34CrAl6) 1.8507 (34CrAlMo5) 1.8506 (31CrAlS5) 1.8519 (31CrMoV9)
P.8	Vergütungsstähle/heart tempered steels <850 N/mm	1.7225 (42CrMo4) 1.7707 (30CrMoV9) 1.5864 (35NiCr8) 1.601 (C60)
P.9	Werkzeugstähle (legiert und unlegiert)/tool steels <1000 N/mm	1.2056 (90Cr3) 1.2823 (70Si7) 1.2080 (X210Cr12) 12312 (40CrMnMoS86)
M.1	Rost- und säurebeständige Stähle <750 N/mm corrosion- and acid-resistant steels <750 N/mm	1.4301 (X5CrNi1810) 1.4305 (X8CrNiS18.9) 1.4404 (X2CrNiMo17-12-2) 1.4573 (X10CrNiMoTi18-12)
M.2	Rost- und säurebeständige Stähle <750 N/mm corrosion- and acid-resistant steels <750 N/mm	1.4021 (X20Cr13) 1.4112 (X90CrMoV18) 1.4512 (X6CrTi12) 1.4125 (X105CrMo17)
K.1	Gusseisen/cast iron <200 HB	0.6015 (GG-15) 0.6030 (GG-30) 0.6025 (GG-25) 0.6020 (GG-20)
K.2	Temperguss/malleable cast iron	0.8035 (GTW-35-04) 0.8045 (GTW-4507) 0.8145 (GTS-45-06) 0.8165 (GTS-65-02)
K.3	Gusseisen mit Kugelgraphit/ductile cast iron	0.7040 (GGG-40) 0.7050 (GGG-50) 0.7060 (GGG-60)
N.1	AL- und AL-Legierung/AL- and AL-alloys <5% Si	3.1841 (G-AlCu4Ti) 3.2134 (G-AlSi5Cu1Mg) 3.0255 (AL99.5) 3.0515 AlMn1
N.2	AL- und AL-Legierung/AL- and AL-alloys <10% Si	3.2152 (GD-AlSi6Cu4) 3.2373 (G-ALSi9Mg) 3.2581 (G-ALSi12) 3.2982 (GD-AlSi12)
N.3	AL-Legierung/AL-alloys <10% Si	G-AlSi17Cu4Mg, G-AiSi18CuNiMg, G-AlSi21CuNiMg, G-AlSi25CuNiMg
N.4	Messing, Kupfer, Bronze, Rotguss brass, copper, bronze, red brass	2.0250 (CuZn20) 2.0332 (CuZn37Pb0,5) 2.0916 (CuAL5) 2.0960 (CuAL9Mn2)
N.5	Duro- und Thermoplaste/duro- and thermoplastics	PF (Bakelit) MF (Albarnit) PTFE (Teflon) POM (Delrin)
N.6	Grafit, GFK/graphite	
S.1	Titan und Titanlegierung/titanium and tit.-alloys	3.7024 (Ti99.5) 3.7164 (TiAl6V4) 3.7124 (TiCu2) 3.7184 (TiAl4Mo4Sn2)
S.1	Nickel/nickel	2.4060 (Nickel 200) 2.4360 (Monel 400) 2.4812 (Hastelloy C) 1.4876 (Incoloy 800)
H.1	gehärtete Stähle/hardened steels 45-52 HRC	Hardox 500, Weldox 1100, 1.2713 (55NiCrMoV6)
H.2	gehärtete Stähle/hardened steels 52-60 HRC	Armox 600T, 1.2542 (4SWcrV7)
H.3	gehärtete Stähle/hardened steels 60-65 HRC	1.2379 (X55CrVmo12-1) 1.2436 (X210CrW12) HSSE



PRODUKTFINDER



Artikel		BV-H30002	BV-H31002	BV-H51002	BV-D00338	BV-DB0338	BV-D01897	BV-DB1897
Substrat		VHM	VHM	VHM	VHM	VHM	VHM	VHM
Drm.-Bereich		1-20	3-20	1-20	0,5-12	0,5-12	0,5-12	0,5-12
Spitze		140°	140°	140°	118°	118°	118°	118°
DIN		WN	WN	WN	DN338	DN338	DN1897	DN1897
Einsatztiefe		3xD	3xD	5xD	-	-	-	-
Seite		22	27	31	36	36	43	43
	BOHRWERKZEUGE							
P.1		●	●	●	●	●	●	●
P.2		●	●	●	●	●	●	●
P.3		●	●	●	●	●	●	●
P.4		●	●	●	●	●	●	●
P.5		●	●	●	●	●	●	●
P.6		●	●	●	●	●	●	●
P.7		●	●	●	●	●	●	●
P.8		●	●	●	●	●	●	●
P.9		●	●	●	●	●	●	●
M.1		●	●	●	●	●	●	●
M.2		●	●	●	●	●	●	●
K.1		●	●	●	●	●	●	●
K.2		●	●	●	●	●	●	●
K.3		●	●	●	●	●	●	●
N.1		●	●	●	●	●	●	●
N.2		●	●	●	●	●	●	●
N.3		●	●	●	●	●	●	●
N.4		●	●	●	●	●	●	●
N.5		●	●	●	●	●	●	●
N.6	●	●	●	●	●	●	●	
S.1	●	●	●	●	●	●	●	
S.1	●	●	●	●	●	●	●	
H.1	●	●	●	●	●	●	●	
H.2	●	●	●	●	●	●	●	
H.3	●	●	●	●	●	●	●	



PRODUKTFINDER



Artikel	BV-NC0901	BV-NC1201	BV-NC1421	BH-NC0911	BH-NC1212	BH-ZA001	BH-ZR002
Substrat	VHM	VHM	VHM	HSS-E	HSS-E	HSS	HSS
Drm.-Bereich	2-16	2-16	3-16	3-25	3-25	0,5-10	0,5-10
Spitze	90°	120°	142°	90°	120°	60°	60°
DIN	WN	WN	WN	WN	WN	333	333
Einsatztiefe	-	-	-	-	-	-	-
Seite	50	52	54	56	58	60	62
P.1	●	●	●	●	●	●	●
P.2	●	●	●	●	●	●	●
P.3	●	●	●	●	●	●	●
P.4	●	●	●	●	●	●	●
P.5	●	●	●	●	●	●	●
P.6	●	●	●	●	●	●	●
P.7	●	●	●	●	●	●	●
P.8	●	●	●	●	●	●	●
P.9	●	●	●	●	●	●	●
M.1	●	●	●	●	●	●	●
M.2	●	●	●	●	●	●	●
K.1	●	●	●	●	●	●	●
K.2	●	●	●	●	●	●	●
K.3	●	●	●	●	●	●	●
N.1	●	●	●	●	●	●	●
N.2	●	●	●	●	●	●	●
N.3	●	●	●	●	●	●	●
N.4	●	●	●			●	●
N.5	●	●	●				
N.6							
S.1							
S.1							
H.1							
H.2							
H.3							



PRODUKTFINDER



Artikel		GH-B10001	GH-B20001	GH-B10002	GH-B20002	GH-F10001	GH-S10002
Typ		Dulo	Salo	Dulo	Salo		INOX
Gewindeart		M	M	M	M	M	M
Form		B/4-5P	C/2-3P	B/4-5P	C/2-3P	C/2-3P	2,25P
Toleranz		6H	6H	6HX	6HX	6HX	6g
DIN		371/376	371/376	371/376	371/376	371/376	13
Substrat		HSSE/PM	HSSE/PM	HSSE/PM	HSSE/PM	HSSE/PM	HSSE
Seite		68	70	72	76	80	82
P.1	GEWINDEWERKZEUGE	●	●	●	●	●	
P.2		●	●	●	●	●	
P.3		●	●	●	●	●	
P.4		●	●	●	●	●	
P.5		●	●	●	●	●	
P.6		●	●	●	●	●	
P.7		●	●	●	●	●	
P.8		●	●	●	●	●	
P.9		●	●	●	●	●	
M.1		●	●	●	●	●	
M.2		●	●	●	●	●	
K.1		●	●	●	●	●	
K.2		●	●	●	●	●	
K.3		●	●	●	●	●	
N.1		●	●	●	●	●	
N.2		●	●	●	●	●	
N.3		●	●	●	●	●	
N.4		●	●	●	●	●	
N.5		●	●	●	●	●	
N.6		●	●	●	●	●	
S.1				●	●		
S.1				●	●		
H.1							
H.2							
H.3							



Artikel		RV-VE4501	RV-E06001	RV-E09001	Artikel	RV-R01001	RV-R01002
Substrat		VHM	VHM	VHM	Substrat	VHM	VHM
Drm.-Bereich		2-16	4-20	1-20	Drm.-Bereich	0,1-20,1	1,10-20,1
Winkel		45°	60°	90°	Drall	Linksdrall	Rechtsdrall
DIN		WN	WN	WN	DIN	WN	WN
Zähnezahl		3-4	4-6	3-6	Art	1/100	1/100
Seite		86	88	90	Seite	94	97
P.1	ENTGRATWERKZEUGE	•	•	•	REIBAHLEN	•	•
P.2		•	•	•		•	•
P.3		•	•	•		•	•
P.4		•	•	•		•	•
P.5		•	•	•		•	•
P.6		•	•	•		•	•
P.7		•	•	•		•	•
P.8		•	•	•		•	•
P.9		•	•	•		•	•
M.1		•	•	•		•	•
M.2		•	•	•		•	•
K.1		•	•	•		•	•
K.2		•	•	•		•	•
K.3		•	•	•		•	•
N.1		•	•	•		•	•
N.2		•	•	•		•	•
N.3		•	•	•		•	•
N.4		•	•	•		•	•
N.5		•	•	•		•	•
N.6		•	•	•		•	•
S.1			•	•			
S.1			•	•			
H.1							
H.2							
H.3							



PRODUKTFINDER



Artikel	RV-R12001	RV-R11001	RV-R01003	RH-RA005	RH-R01006	RH-R01007
Substrat	VHM	VHM	VHM	HSS-E	HSS-E	HSS-E
Drm.-Bereich	2,95-16,25	2,90-14,1	1,0-12,0	1,5-20,0	0,9-13,2	1,0-20,0
Drall	gerade genutet	gerade genutet	Linksdrall	Linksdrall	Linksdrall	Linksdrall
DIN	WN	WN	DIN 212	DIN 8089	DIN 212	DIN 212
Art	1/100	1/100	H7	H7	1/100	H7
Seite	100	102	104	110	112	114
P.1	●	●	●	●	●	●
P.2	●	●	●	●	●	●
P.3	●	●	●	●	●	●
P.4	●	●	●	●	●	●
P.5	●	●	●	●	●	●
P.6	●	●	●	●	●	●
P.7	●	●	●	●	●	●
P.8	●	●	●	●	●	●
P.9	●	●	●	●	●	●
M.1	●	●	●	●	●	●
M.2	●	●	●	●	●	●
K.1	●	●	●	●	●	●
K.2	●	●	●	●	●	●
K.3						
N.1			●	●	●	●
N.2			●	●	●	●
N.3			●			
N.4			●	●	●	●
N.5			●			
N.6			●			
S.1				●	●	●
S.1						
H.1						
H.2						
H.3						



PRODUKTFINDER



Artikel		RH-K09001	RH-K09011	RH-K09002	RH-K09013	Artikel	FV-HPC101	FV-HPC102
Substrat		HSS	HSS-TIN	HSS	HSS-UT	Substrat	VHM	VHM
Drm.-Bereich		4,3-40,0	4,3-40,0	6,3-31,0	4,3-31,0	Drm.-Bereich	3-20	3-20
Winkel		90°	90°	90°	90°	Länge	kurz	lang abgesetzt
DIN		335	335	überlang	335	Schaftart	HB	HB
Zähnezahl		3	3	3	3	Zähnezahl	4	4
Seite		116	120	122	124	Seite	132	134

P.1	KEGELSENKER	●	●	●	●	FRÄSWERKZEUGE	●	●
P.2		●	●	●	●		●	●
P.3		●	●	●	●		●	●
P.4		●	●	●	●		●	●
P.5		●	●	●	●		●	●
P.6		●	●	●	●		●	●
P.7		●	●	●	●		●	●
P.8		●	●	●	●		●	●
P.9		●	●	●	●		●	●
M.1		●	●	●	●			
M.2		●	●	●	●			
K.1		●	●	●	●	●	●	
K.2		●	●	●	●	●	●	
K.3					●	●	●	
N.1		●	●	●	●			
N.2		●	●	●	●			
N.3		●	●	●	●			
N.4		●	●	●	●			
N.5		●	●	●	●			
N.6								
S.1			●					
S.1								
H.1								
H.2								
H.3								



PRODUKTFINDER



Artikel	FV-HPC103	FV-HPC104	FV-MTC120	FV-FIN530	FV-HPC205	FV-HPC206	FV-HPC510	FV-HPC511
Substrat	VHM	VHM	VHM	VHM	VHM	VHM	VHM	VHM
Drm.-Bereich	3-20	3-20	6-20	3-25	3-20	3-20	3-20	3-20
Länge	kurz	lang abgesetzt	lang abgesetzt	lang abgesetzt	kurz	lang abgesetzt	kurz	lang abgesetzt
Schaftart	HB	HB	HB	HA	HB	HB	HB	HB
Zähnezahl	4	4	4	5-6	4	4	4	4
Seite	136	138	140	142	144	146	148	150
P.1	●	●	●	●	●	●	●	●
P.2	●	●	●	●	●	●	●	●
P.3	●	●	●	●	●	●	●	●
P.4	●	●	●	●				
P.5	●	●	●	●				
P.6	●	●	●	●				
P.7	●	●	●	●				
P.8	●	●	●	●				
P.9	●	●	●	●				
M.1			●	●	●	●	●	●
M.2			●	●	●	●	●	●
K.1	●	●	●	●	●	●	●	●
K.2	●	●	●	●	●	●	●	●
K.3	●	●	●	●	●	●	●	●
N.1								
N.2								
N.3								
N.4								
N.5								
N.6								
S.1			●		●	●	●	●
S.1			●		●	●	●	●
H.1								
H.2								
H.3								



PRODUKTFINDER



Artikel		FV-MTC221	FV-FIN231	FV-KON362	FV-KON360	FV-HPC361	FV-MTC365	FV-MTC375	
Substrat		VHM	VHM	VHM	VHM	VHM	VHM	VHM	
Drm.-Bereich		4-25	6-20	1-12	1-20	3-20	6-20	6-20	
Länge		lang abgesetzt	überlang	kurz	lang	lang abgesetzt	lang abgesetzt	lang abgesetzt	
Schaftart		HB	HB	HA	HA	HA	HA	HA	
Zähnezahl		3-6	5	1	2	3	3	3	
Seite		152	154	156	158	160	162	164	
	FRÄSWERKZEUGE								
P.1		●	●						
P.2		●	●						
P.3		●	●						
P.4		●	●						
P.5		●	●						
P.6		●	●						
P.7		●	●						
P.8		●	●						
P.9		●	●						
M.1		●	●						
M.2		●	●						
K.1		●	●						
K.2		●	●						
K.3		●	●						
N.1				●	●	●	●	●	●
N.2					●	●	●	●	●
N.3					●	●	●	●	●
N.4				●	●	●	●	●	●
N.5					●	●	●	●	●
N.6									
S.1			●						
S.1			●						
H.1									
H.2									
H.3									



PRODUKTFINDER



Artikel		KS-VF10001	KS-VG20001	KS-HF10001	KS-HG20001	KS-HG30001
Substrat		VHM	VHM	HSS	HSS	HSS
Drm.-Bereich		15-200	15-200	20-315	50-315	50-315
DIN		1837	1838	1837	1838	1838
Form		A	B	A	B	C
Seite		172	184	196	203	208
P.1	KREISSÄGEBLÄTTER	•	•	•	•	•
P.2		•	•	•	•	•
P.3		•	•	•	•	•
P.4		•	•	•	•	•
P.5		•	•	•	•	•
P.6		•	•	•	•	•
P.7		•	•	•	•	•
P.8		•	•	•	•	•
P.9		•	•	•	•	•
M.1	SÄGEBLÄTTER	•	•	•	•	•
M.2		•	•	•	•	•
K.1		•	•	•	•	•
K.2	•	•	•	•	•	
K.3						
N.1	SÄGEBLÄTTER	•	•	•	•	•
N.2		•	•	•	•	•
N.3		•	•	•	•	•
N.4		•	•	•	•	•
N.5		•	•	•	•	•
N.6						
S.1						
S.1						
H.1						
H.2						
H.3						



**HALLAS
TOOLS**

Sonderwerkzeuge
im **Fräs-** und **Bohrbereich**
auch als Express-Service
innerhalb von

5-8 ARBEITSTAGEN

inklusive Beschichtung
lieferbar!

VHM-Reibahlen in
unseren Werksausführungen
mit 2 Stellen nach
dem Komma
(z.Bsp. 7,58mm),
als Passungsreibahlen
(z. Bsp. 8H11) oder
Reibahlen mit einer
eingeschränkten Toleranz
(z. Bsp. 12,089 +0,002/+0,006)
können wir innerhalb von

48 STUNDEN

liefern!



**HALLAS
TOOLS**



BESCHREIBUNG WERKZEUGE

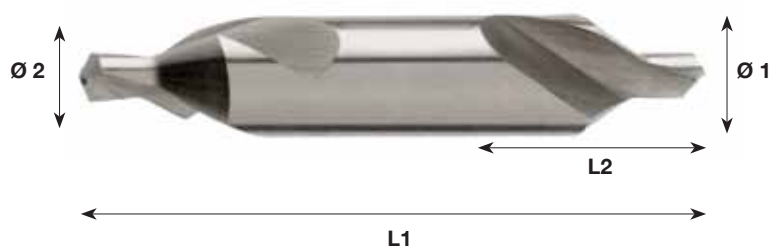
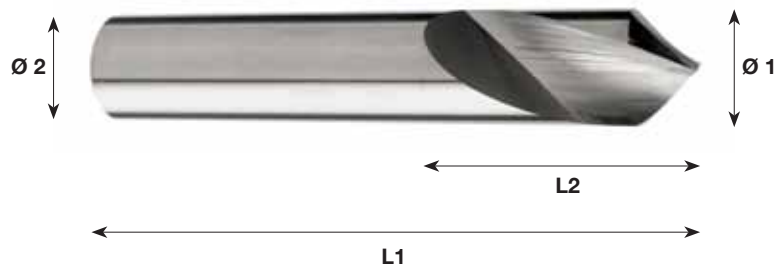
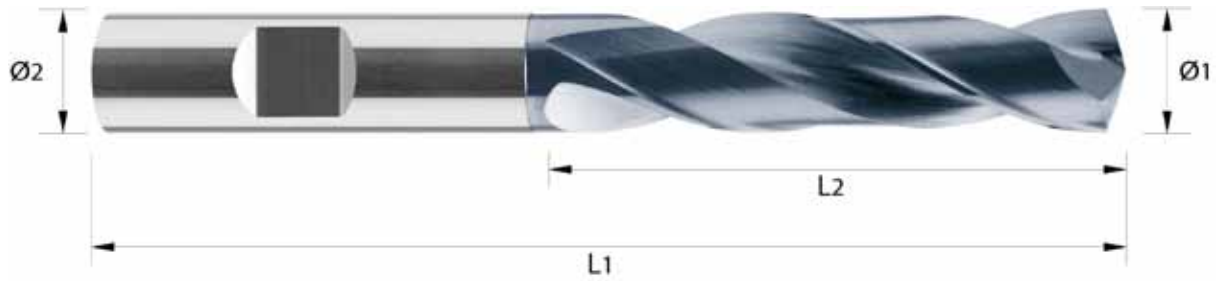

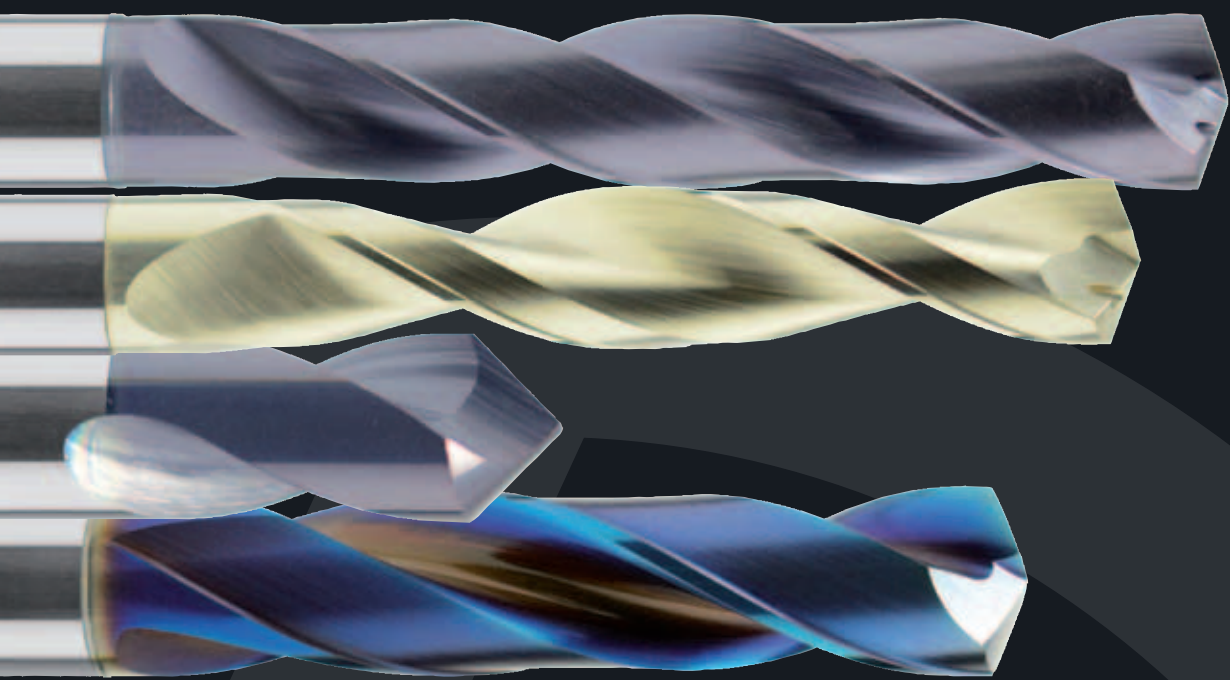

HALLAS
TOOLS

BOHRWERKZEUGE

**INHALTSVERZEICHNIS BOHRWERKZEUGE**

Artikel	BV-H30002	BV-H31002	BV-H51002	BV-D00338	BV-DB0338	BV-D01897	BV-DB1897
Substrat	VHM	VHM	VHM	VHM	VHM	VHM	VHM
Drm.-Bereich	1-20	3-20	1-20	0,5-12	0,5-12	0,5-12	0,5-12
Spitze	140°	140°	140°	118°	118°	118°	118°
DIN	WN	WN	WN	DN338	DN338	DN1897	DN1897
Einsatztiefe	3xD	3xD	5xD	-	-	-	-
Seite	22	27	31	36	36	43	43
P.1	●	●	●	●	●	●	●
P.2	●	●	●	●	●	●	●
P.3	●	●	●	●	●	●	●
P.4	●	●	●	●	●	●	●
P.5	●	●	●	●	●	●	●
P.6	●	●	●	●	●	●	●
P.7	●	●	●	●	●	●	●
P.8	●	●	●	●	●	●	●
P.9	●	●	●	●	●	●	●
M.1	●	●	●	●	●	●	●
M.2	●	●	●	●	●	●	●
K.1	●	●	●	●	●	●	●
K.2	●	●	●	●	●	●	●
K.3	●	●	●	●	●	●	●
N.1	●	●	●	●	●	●	●
N.2	●	●	●	●	●	●	●
N.3	●	●	●	●	●	●	●
N.4	●	●	●	●	●	●	●
N.5	●	●	●	●	●	●	●
N.6	●	●	●	●	●	●	●
S.1	●	●	●	●	●	●	●
S.1	●	●	●	●	●	●	●
H.1							
H.2							
H.3							



Artikel	BV-NC0901	BV-NC1201	BV-NC1421	BH-NC0911	BH-NC1212	BH-ZA001	BH-ZR002
Substrat	VHM	VHM	VHM	HSS-E	HSS-E	HSS	HSS
Drm.-Bereich	2-16	2-16	3-16	3-25	3-25	0,5-10	0,5-10
Spitze	90°	120°	142°	90°	120°	60°	60°
DIN	WN	WN	WN	WN	WN	333	333
Einsatztiefe	-	-	-	-	-	-	-
Seite	50	52	54	56	58	60	62
P.1	●	●	●	●	●	BHZA001	BHZR002
P.2	●	●	●	●	●	HSS	HSS
P.3	●	●	●	●	●	0,5-12,5	0,5-12,5
P.4	●	●	●	●	●	60°	60°
P.5	●	●	●	●	●	333	333
P.6	●	●	●	●	●	-	-
P.7	●	●	●	●	●	44	46
P.8	●	●	●	●	●		
P.9	●	●	●	●	●		
M.1	●	●	●	●	●	●	●
M.2	●	●	●	●	●	●	●
K.1	●	●	●	●	●	●	●
K.2	●	●	●	●	●	●	●
K.3	●	●	●	●			
N.1	●	●	●	●	●	●	●
N.2	●	●	●	●	●	●	●
N.3	●	●	●	●	●	●	●
N.4	●	●	●			●	●
N.5	●	●	●				
N.6							
S.1							
S.1							
H.1							
H.2							
H.3							



BV-H30002

VHM SPIRALBOHRER 3XD OHNE INNENKÜHLUNG

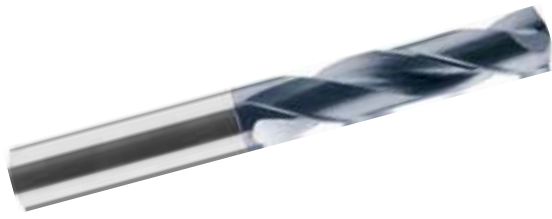
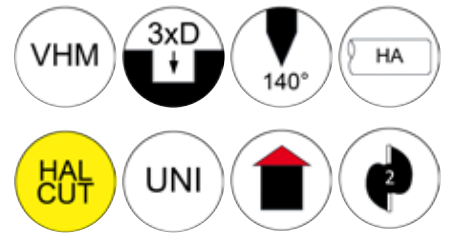

Artikel-Nr. Article-No.	D1 m7	D2 h6	L2	L1	Preis/Euro Price/Euro
BV-H30002.0100B.3D	1,00	4	7	45	31,90 €
BV-H30002.0110B.3D	1,10	4	7	45	31,90 €
BV-H30002.0120B.3D	1,20	4	7	45	31,90 €
BV-H30002.0130B.3D	1,30	4	7	45	31,90 €
BV-H30002.0140B.3D	1,40	4	7	45	31,90 €
BV-H30002.0150B.3D	1,50	4	14	55	31,90 €
BV-H30002.0160B.3D	1,60	4	14	55	31,90 €
BV-H30002.0170B.3D	1,70	4	14	55	31,90 €
BV-H30002.0180B.3D	1,80	4	14	55	31,90 €
BV-H30002.0190B.3D	1,90	4	14	55	31,90 €
BV-H30002.0200B.3D	2,00	4	20	55	31,90 €
BV-H30002.0210B.3D	2,10	4	20	55	31,90 €
BV-H30002.0220B.3D	2,20	4	20	55	31,90 €
BV-H30002.0230B.3D	2,30	4	20	55	31,90 €
BV-H30002.0240B.3D	2,40	4	20	55	31,90 €
BV-H30002.0250B.3D	2,50	4	20	55	31,90 €
BV-H30002.0260B.3D	2,60	4	20	55	31,90 €
BV-H30002.0270B.3D	2,70	4	20	55	31,90 €
BV-H30002.0280B.3D	2,80	4	20	55	31,90 €
BV-H30002.0290B.3D	2,90	4	20	55	31,90 €
BV-H30002.0300B.3D	3,00	6	20	62	31,90 €
BV-H30002.0310B.3D	3,10	6	20	62	31,90 €
BV-H30002.0320B.3D	3,20	6	20	62	31,90 €
BV-H30002.0325B.3D	3,25	6	20	62	31,90 €
BV-H30002.0330B.3D	3,30	6	20	62	31,90 €
BV-H30002.0340B.3D	3,40	6	20	62	31,90 €
BV-H30002.0350B.3D	3,50	6	20	62	31,90 €
BV-H30002.0360B.3D	3,60	6	20	62	31,90 €
BV-H30002.0370B.3D	3,70	6	20	62	31,90 €
BV-H30002.0380B.3D	3,80	6	24	66	31,90 €
BV-H30002.0390B.3D	3,90	6	24	66	31,90 €
BV-H30002.0400B.3D	4,00	6	24	66	31,90 €
BV-H30002.0410B.3D	4,10	6	24	66	31,90 €
BV-H30002.0420B.3D	4,20	6	24	66	31,90 €
BV-H30002.0430B.3D	4,30	6	24	66	31,90 €
BV-H30002.0440B.3D	4,40	6	24	66	31,90 €
BV-H30002.0450B.3D	4,50	6	24	66	31,90 €

**BV-H30002
VHM SPIRALBOHRER 3XD OHNE INNENKÜHLUNG**

BV-H30002.0460B.3D	4,60	6	24	66	31,90 €
BV-H30002.0465B.3D	4,65	6	24	66	31,90 €
BV-H30002.0470B.3D	4,70	6	24	66	31,90 €
BV-H30002.0480B.3D	4,80	6	28	66	31,90 €
BV-H30002.0490B.3D	4,90	6	28	66	31,90 €
BV-H30002.0500B.3D	5,00	6	28	66	31,90 €
BV-H30002.0510B.3D	5,10	6	28	66	31,90 €
BV-H30002.0520B.3D	5,20	6	28	66	31,90 €
BV-H30002.0530B.3D	5,30	6	28	66	31,90 €
BV-H30002.0540B.3D	5,40	6	28	66	31,90 €
BV-H30002.0550B.3D	5,50	6	28	66	31,90 €
BV-H30002.0555B.3D	5,55	6	28	66	31,90 €
BV-H30002.0560B.3D	5,60	6	28	66	31,90 €
BV-H30002.0570B.3D	5,70	6	28	66	31,90 €
BV-H30002.0580B.3D	5,80	6	28	66	31,90 €
BV-H30002.0590B.3D	5,90	6	28	66	31,90 €
BV-H30002.0600B.3D	6,00	6	28	66	31,90 €
BV-H30002.0610B.3D	6,10	8	34	79	37,65 €
BV-H30002.0620B.3D	6,20	8	34	79	37,65 €
BV-H30002.0630B.3D	6,30	8	34	79	37,65 €
BV-H30002.0640B.3D	6,40	8	34	79	37,65 €
BV-H30002.0650B.3D	6,50	8	34	79	37,65 €
BV-H30002.0660B.3D	6,60	8	34	79	37,65 €
BV-H30002.0670B.3D	6,70	8	34	79	37,65 €
BV-H30002.0680B.3D	6,80	8	34	79	37,65 €
BV-H30002.0690B.3D	6,90	8	34	79	37,65 €
BV-H30002.0700B.3D	7,00	8	34	79	37,65 €
BV-H30002.0710B.3D	7,10	8	41	79	37,65 €
BV-H30002.0720B.3D	7,20	8	41	79	37,65 €
BV-H30002.0730B.3D	7,30	8	41	79	37,65 €
BV-H30002.0740B.3D	7,40	8	41	79	37,65 €
BV-H30002.0750B.3D	7,50	8	41	79	37,65 €
BV-H30002.0760B.3D	7,60	8	41	79	37,65 €
BV-H30002.0770B.3D	7,70	8	41	79	37,65 €
BV-H30002.0780B.3D	7,80	8	41	79	37,65 €
BV-H30002.0790B.3D	7,90	8	41	79	37,65 €
BV-H30002.0800B.3D	8,00	8	41	79	37,65 €
BV-H30002.0810B.3D	8,10	10	47	89	50,55 €
BV-H30002.0820B.3D	8,20	10	47	89	50,55 €
BV-H30002.0830B.3D	8,30	10	47	89	50,55 €
BV-H30002.0840B.3D	8,40	10	47	89	50,55 €
BV-H30002.0850B.3D	8,50	10	47	89	50,55 €
BV-H30002.0860B.3D	8,60	10	47	89	50,55 €
BV-H30002.0870B.3D	8,70	10	47	89	50,55 €
BV-H30002.0880B.3D	8,80	10	47	89	50,55 €



BV-H30002 VHM SPIRALBOHRER 3XD OHNE INNENKÜHLUNG

BV-H30002.0890B.3D	8,90	10	47	89	50,55 €
BV-H30002.0900B.3D	9,00	10	47	89	50,55 €
BV-H30002.0910B.3D	9,10	10	47	89	50,55 €
BV-H30002.0920B.3D	9,20	10	47	89	50,55 €
BV-H30002.0930B.3D	9,30	10	47	89	50,55 €
BV-H30002.0940B.3D	9,40	10	47	89	50,55 €
BV-H30002.0950B.3D	9,50	10	47	89	50,55 €
BV-H30002.0960B.3D	9,60	10	47	89	50,55 €
BV-H30002.0970B.3D	9,70	10	47	89	50,55 €
BV-H30002.0980B.3D	9,80	10	47	89	50,55 €
BV-H30002.0990B.3D	9,90	10	47	89	50,55 €
BV-H30002.1000B.3D	10,00	10	47	89	50,55 €
BV-H30002.1010B.3D	10,10	12	55	102	67,25 €
BV-H30002.1020B.3D	10,20	12	55	102	67,25 €
BV-H30002.1030B.3D	10,30	12	55	102	67,25 €
BV-H30002.1040B.3D	10,40	12	55	102	67,25 €
BV-H30002.1050B.3D	10,50	12	55	102	67,25 €
BV-H30002.1060B.3D	10,60	12	55	102	67,25 €
BV-H30002.1070B.3D	10,70	12	55	102	67,25 €
BV-H30002.1080B.3D	10,80	12	55	102	67,25 €
BV-H30002.1090B.3D	10,90	12	55	102	67,25 €
BV-H30002.1100B.3D	11,00	12	55	102	67,25 €
BV-H30002.1110B.3D	11,10	12	55	102	67,25 €
BV-H30002.1120B.3D	11,20	12	55	102	67,25 €
BV-H30002.1130B.3D	11,30	12	55	102	67,25 €
BV-H30002.1140B.3D	11,40	12	55	102	67,25 €
BV-H30002.1150B.3D	11,50	12	55	102	67,25 €
BV-H30002.1160B.3D	11,60	12	55	102	67,25 €
BV-H30002.1170B.3D	11,70	12	55	102	67,25 €
BV-H30002.1180B.3D	11,80	12	55	102	67,25 €
BV-H30002.1190B.3D	11,90	12	55	102	67,25 €
BV-H30002.1200B.3D	12,00	12	55	102	67,25 €
BV-H30002.1220B.3D	12,20	14	60	107	88,45 €
BV-H30002.1230B.3D	12,30	14	60	107	88,45 €
BV-H30002.1250B.3D	12,50	14	60	107	88,45 €
BV-H30002.1280B.3D	12,80	14	60	107	88,45 €
BV-H30002.1300B.3D	13,00	14	60	107	88,45 €
BV-H30002.1350B.3D	13,50	14	60	107	88,45 €
BV-H30002.1380B.3D	13,80	14	60	107	88,45 €
BV-H30002.1400B.3D	14,00	14	60	107	88,45 €
BV-H30002.1420B.3D	14,20	16	65	115	113,10 €
BV-H30002.1450B.3D	14,50	16	65	115	113,10 €
BV-H30002.1480B.3D	14,80	16	65	115	113,10 €
BV-H30002.1500B.3D	15,00	16	65	115	113,10 €
BV-H30002.1510B.3D	15,10	16	65	115	113,10 €



BV-H30002
VHM SPIRALBOHRER 3XD OHNE INNENKÜHLUNG

BV-H30002.1520B.3D	15,20	16	65	115	113,10 €
BV-H30002.1550B.3D	15,50	16	65	115	113,10 €
BV-H30002.1580B.3D	15,80	16	65	115	113,10 €
BV-H30002.1600B.3D	16,00	16	65	115	113,10 €
BV-H30002.1650B.3D	16,50	18	73	123	131,00 €
BV-H30002.1680B.3D	16,80	18	73	123	131,00 €
BV-H30002.1700B.3D	17,00	18	73	123	131,00 €
BV-H30002.1730B.3D	17,30	18	73	123	148,10 €
BV-H30002.1750B.3D	17,50	18	73	123	148,10 €
BV-H30002.1770B.3D	17,70	18	73	123	148,10 €
BV-H30002.1780B.3D	17,80	18	73	123	148,10 €
BV-H30002.1800B.3D	18,00	18	73	123	148,10 €
BV-H30002.1850B.3D	18,50	20	79	131	193,05 €
BV-H30002.1900B.3D	19,00	20	79	131	193,05 €
BV-H30002.1930B.3D	19,30	20	79	131	193,05 €
BV-H30002.1950B.3D	19,50	20	79	131	193,05 €
BV-H30002.1980B.3D	19,80	20	79	131	193,05 €
BV-H30002.2000B.3D	20,00	20	79	131	193,05 €





BV-H30002

VHM SPIRALBOHRER 3XD OHNE INNENKÜHLUNG

MATERIALBESCHREIBUNG

		Vc m/min		f mm/U		f mm/U		f mm/U		f mm/U	
		von	bis	Ø 3,0-6,0	von/bis	Ø 6,0-10,0	von/bis	Ø 10,0-16,0	von/bis	Ø 16,0-20,0	von/bis
P.1	<500N/mm	80	100	0,080	0,150	0,150	0,200	0,200	0,250	0,250	0,350
P.2	<650N/mm	80	100	0,080	0,150	0,150	0,200	0,200	0,250	0,250	0,350
P.3	<800N/mm	80	100	0,080	0,150	0,150	0,200	0,200	0,250	0,250	0,350
P.4	<1000N/mm	70	90	0,080	0,150	0,150	0,200	0,200	0,250	0,250	0,350
P.5	<1400N/mm	30	50	0,060	0,120	0,120	0,150	0,150	0,200	0,200	0,300
P.6	Einsatz-ST <1000N/mm	60	80	0,070	0,130	0,130	0,160	0,160	0,220	0,220	0,300
P.7	Nitrier-ST <1000N/mm	60	80	0,070	0,130	0,130	0,160	0,160	0,220	0,220	0,300
P.8	Vergütung-ST 850N/mm	50	70	0,070	0,130	0,130	0,160	0,160	0,220	0,220	0,300
P.9	Werkzeug-ST 1000N/mm	30	50	0,060	0,120	0,120	0,150	0,150	0,200	0,200	0,300
M.1	VA <750N/mm	30	50	0,060	0,100	0,100	0,150	0,150	0,180	0,180	0,250
M.2	VA >750N/mm	25	40	0,060	0,100	0,100	0,150	0,150	0,180	0,180	0,250
K.1	Gusseisen <200HB	100	120	0,050	0,130	0,130	0,170	0,170	0,220	0,220	0,350
K.2	Temperguss	100	120	0,050	0,130	0,130	0,170	0,170	0,220	0,220	0,350
K.3	Gusseisen mit Kugelgraphit	80	110	0,050	0,130	0,130	0,170	0,170	0,220	0,220	0,350
N.1	AL <5%	200	250	0,080	0,150	0,150	0,200	0,200	0,250	0,250	0,350
N.2	AL <10%	160	200	0,080	0,150	0,150	0,200	0,200	0,250	0,250	0,350
N.3	AL >10%	120	180	0,080	0,150	0,150	0,200	0,200	0,250	0,250	0,350
N.4	Ms, Cu, Bronze, Rotguss	10	200	0,080	0,150	0,150	0,200	0,200	0,250	0,250	0,350
N.5	Duro-Thermoplast										
N.6	Grafit, GFK										
S.1	Titan	25	40	0,060	0,100	0,100	0,150	0,150	0,180	0,180	0,250
S.2	Nickel										
H.1	45-52 HRC										
H.2	52-60 HRC										
H.3	60-65 HRC										

BV-H31002

VHM SPIRALBOHRER 3XD MIT INNENKÜHLUNG

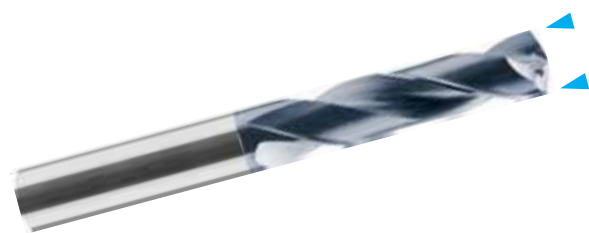

Artikel-Nr. Article-No.	D1 m7	D2 h6	L2	L1	Preis/Euro Price/Euro
BV-H31002.0300B.3D	3,00	6	20	62	42,25 €
BV-H31002.0310B.3D	3,10	6	20	62	42,25 €
BV-H31002.0320B.3D	3,20	6	20	62	42,25 €
BV-H31002.0325B.3D	3,25	6	20	62	42,25 €
BV-H31002.0330B.3D	3,30	6	20	62	42,25 €
BV-H31002.0340B.3D	3,40	6	20	62	42,25 €
BV-H31002.0350B.3D	3,50	6	20	62	42,25 €
BV-H31002.0360B.3D	3,60	6	20	62	42,25 €
BV-H31002.0370B.3D	3,70	6	20	62	42,25 €
BV-H31002.0380B.3D	3,80	6	24	66	42,25 €
BV-H31002.0390B.3D	3,90	6	24	66	42,25 €
BV-H31002.0400B.3D	4,00	6	24	66	42,25 €
BV-H31002.0410B.3D	4,10	6	24	66	42,25 €
BV-H31002.0420B.3D	4,20	6	24	66	42,25 €
BV-H31002.0430B.3D	4,30	6	24	66	42,25 €
BV-H31002.0440B.3D	4,40	6	24	66	42,25 €
BV-H31002.0450B.3D	4,50	6	24	66	42,25 €
BV-H31002.0460B.3D	4,60	6	24	66	42,25 €
BV-H31002.0465B.3D	4,65	6	24	66	42,25 €
BV-H31002.0470B.3D	4,70	6	24	66	42,25 €
BV-H31002.0480B.3D	4,80	6	28	66	42,25 €
BV-H31002.0490B.3D	4,90	6	28	66	42,25 €
BV-H31002.0500B.3D	5,00	6	28	66	42,25 €
BV-H31002.0510B.3D	5,10	6	28	66	42,25 €
BV-H31002.0520B.3D	5,20	6	28	66	42,25 €
BV-H31002.0530B.3D	5,30	6	28	66	42,25 €
BV-H31002.0540B.3D	5,40	6	28	66	42,25 €
BV-H31002.0550B.3D	5,50	6	28	66	42,25 €
BV-H31002.0555B.3D	5,55	6	28	66	42,25 €
BV-H31002.0560B.3D	5,60	6	28	66	42,25 €
BV-H31002.0570B.3D	5,70	6	28	66	42,25 €
BV-H31002.0580B.3D	5,80	6	28	66	42,25 €
BV-H31002.0590B.3D	5,90	6	28	66	42,25 €
BV-H31002.0600B.3D	6,00	6	28	66	42,25 €
BV-H31002.0610B.3D	6,10	8	34	79	57,15 €
BV-H31002.0620B.3D	6,20	8	34	79	57,15 €
BV-H31002.0630B.3D	6,30	8	34	79	57,15 €



BV-H31002

VHM SPIRALBOHRER 3XD MIT INNENKÜHLUNG

BV-H31002.0640B.3D	6,40	8	34	79	57,15 €
BV-H31002.0650B.3D	6,50	8	34	79	57,15 €
BV-H31002.0660B.3D	6,60	8	34	79	57,15 €
BV-H31002.0670B.3D	6,70	8	34	79	57,15 €
BV-H31002.0680B.3D	6,80	8	34	79	57,15 €
BV-H31002.0690B.3D	6,90	8	34	79	57,15 €
BV-H31002.0700B.3D	7,00	8	34	79	57,15 €
BV-H31002.0710B.3D	7,10	8	41	79	57,15 €
BV-H31002.0720B.3D	7,20	8	41	79	57,15 €
BV-H31002.0730B.3D	7,30	8	41	79	57,15 €
BV-H31002.0740B.3D	7,40	8	41	79	57,15 €
BV-H31002.0750B.3D	7,50	8	41	79	57,15 €
BV-H31002.0760B.3D	7,60	8	41	79	57,15 €
BV-H31002.0770B.3D	7,70	8	41	79	57,15 €
BV-H31002.0780B.3D	7,80	8	41	79	57,15 €
BV-H31002.0790B.3D	7,90	8	41	79	57,15 €
BV-H31002.0800B.3D	8,00	8	41	79	57,15 €
BV-H31002.0810B.3D	8,10	10	47	89	70,55 €
BV-H31002.0820B.3D	8,20	10	47	89	70,55 €
BV-H31002.0830B.3D	8,30	10	47	89	70,55 €
BV-H31002.0840B.3D	8,40	10	47	89	70,55 €
BV-H31002.0850B.3D	8,50	10	47	89	70,55 €
BV-H31002.0860B.3D	8,60	10	47	89	70,55 €
BV-H31002.0870B.3D	8,70	10	47	89	70,55 €
BV-H31002.0880B.3D	8,80	10	47	89	70,55 €
BV-H31002.0890B.3D	8,90	10	47	89	70,55 €
BV-H31002.0900B.3D	9,00	10	47	89	70,55 €
BV-H31002.0910B.3D	9,10	10	47	89	70,55 €
BV-H31002.0920B.3D	9,20	10	47	89	70,55 €
BV-H31002.0930B.3D	9,30	10	47	89	70,55 €
BV-H31002.0940B.3D	9,40	10	47	89	70,55 €
BV-H31002.0950B.3D	9,50	10	47	89	70,55 €
BV-H31002.0960B.3D	9,60	10	47	89	70,55 €
BV-H31002.0970B.3D	9,70	10	47	89	70,55 €
BV-H31002.0980B.3D	9,80	10	47	89	70,55 €
BV-H31002.0990B.3D	9,90	10	47	89	70,55 €
BV-H31002.1000B.3D	10,00	10	47	89	70,55 €
BV-H31002.1010B.3D	10,10	12	55	102	100,55 €
BV-H31002.1020B.3D	10,20	12	55	102	100,55 €
BV-H31002.1030B.3D	10,30	12	55	102	100,55 €
BV-H31002.1040B.3D	10,40	12	55	102	100,55 €
BV-H31002.1050B.3D	10,50	12	55	102	100,55 €
BV-H31002.1060B.3D	10,60	12	55	102	100,55 €
BV-H31002.1070B.3D	10,70	12	55	102	100,55 €

**BV-H31002
VHM SPIRALBOHRER 3XD MIT INNENKÜHLUNG**

BV-H31002.1080B.3D	10,80	12	55	102	100,55 €
BV-H31002.1090B.3D	10,90	12	55	102	100,55 €
BV-H31002.1100B.3D	11,00	12	55	102	100,55 €
BV-H31002.1110B.3D	11,10	12	55	102	100,55 €
BV-H31002.1120B.3D	11,20	12	55	102	100,55 €
BV-H31002.1130B.3D	11,30	12	55	102	100,55 €
BV-H31002.1140B.3D	11,40	12	55	102	100,55 €
BV-H31002.1150B.3D	11,50	12	55	102	100,55 €
BV-H31002.1160B.3D	11,60	12	55	102	100,55 €
BV-H31002.1170B.3D	11,70	12	55	102	100,55 €
BV-H31002.1180B.3D	11,80	12	55	102	100,55 €
BV-H31002.1190B.3D	11,90	12	55	102	100,55 €
BV-H31002.1200B.3D	12,00	12	55	102	100,55 €
BV-H31002.1220B.3D	12,20	14	60	107	129,05 €
BV-H31002.1230B.3D	12,30	14	60	107	129,05 €
BV-H31002.1250B.3D	12,50	14	60	107	129,05 €
BV-H31002.1280B.3D	12,80	14	60	107	129,05 €
BV-H31002.1300B.3D	13,00	14	60	107	129,05 €
BV-H31002.1350B.3D	13,50	14	60	107	129,05 €
BV-H31002.1380B.3D	13,80	14	60	107	129,05 €
BV-H31002.1400B.3D	14,00	14	60	107	129,05 €
BV-H31002.1420B.3D	14,20	16	65	115	151,55 €
BV-H31002.1450B.3D	14,50	16	65	115	151,55 €
BV-H31002.1480B.3D	14,80	16	65	115	151,55 €
BV-H31002.1500B.3D	15,00	16	65	115	151,55 €
BV-H31002.1510B.3D	15,10	16	65	115	151,55 €
BV-H31002.1520B.3D	15,20	16	65	115	151,55 €
BV-H31002.1550B.3D	15,50	16	65	115	151,55 €
BV-H31002.1580B.3D	15,80	16	65	115	151,55 €
BV-H31002.1600B.3D	16,00	16	65	115	151,55 €
BV-H31002.1650B.3D	16,50	18	73	123	236,80 €
BV-H31002.1680B.3D	16,80	18	73	123	236,80 €
BV-H31002.1700B.3D	17,00	18	73	123	236,80 €
BV-H31002.1730B.3D	17,30	18	73	123	236,80 €
BV-H31002.1750B.3D	17,50	18	73	123	236,80 €
BV-H31002.1770B.3D	17,70	18	73	123	236,80 €
BV-H31002.1780B.3D	17,80	18	73	123	236,80 €
BV-H31002.1800B.3D	18,00	18	73	123	236,80 €
BV-H31002.1850B.3D	18,50	20	79	131	248,48 €
BV-H31002.1900B.3D	19,00	20	79	131	265,65 €
BV-H31002.1930B.3D	19,30	20	79	131	265,65 €
BV-H31002.1950B.3D	19,50	20	79	131	265,65 €
BV-H31002.1980B.3D	19,80	20	79	131	265,65 €
BV-H31002.2000B.3D	20,00	20	79	131	265,65 €



BV-H31002

VHM SPIRALBOHRER 3XD MIT INNENKÜHLUNG

MATERIALBESCHREIBUNG

		Vc m/min von/bis		f mm/U		f mm/U		f mm/U		f mm/U	
				Ø 3,0-6,0 von/bis		Ø 6,0-10,0 von/bis		Ø 10,0-16,0 von/bis		Ø 16,0-20,0 von/bis	
P.1	<500N/mm	100	130	0,120	0,180	0,180	0,230	0,230	0,270	0,270	0,300
P.2	<650N/mm	100	130	0,120	0,180	0,180	0,230	0,230	0,270	0,270	0,300
P.3	<800N/mm	100	130	0,120	0,180	0,180	0,230	0,230	0,270	0,270	0,300
P.4	<1000N/mm	90	120	0,120	0,180	0,180	0,230	0,230	0,270	0,270	0,300
P.5	<1400N/mm	35	55	0,060	0,090	0,090	0,150	0,150	0,200	0,200	0,230
P.6	Einsatz-ST <1000N/mm	80	100	0,100	0,160	0,160	0,200	0,200	0,220	0,220	0,250
P.7	Nitrier-ST <1000N/mm	80	100	0,100	0,160	0,160	0,200	0,200	0,220	0,220	0,250
P.8	Vergütung-ST 850N/mm	80	100	0,100	0,160	0,160	0,200	0,200	0,220	0,220	0,250
P.9	Werkzeug-ST 1000N/mm	50	80	0,100	0,160	0,160	0,200	0,200	0,220	0,220	0,250
M.1	VA <750N/mm	40	60	0,008	0,120	0,120	0,160	0,160	0,200	0,200	0,250
M.2	VA >750N/mm	30	60	0,008	0,120	0,120	0,160	0,160	0,200	0,200	0,250
K.1	Gusseisen <200HB	100	120	0,050	0,130	0,130	0,170	0,170	0,220	0,220	0,300
K.2	Temperguss	100	120	0,050	0,130	0,130	0,170	0,170	0,220	0,220	0,300
K.3	Gusseisen mit Kugelgraphit	100	120	0,050	0,130	0,130	0,170	0,170	0,220	0,220	0,300
N.1	AL <5%	220	260	0,150	0,250	0,250	0,380	0,380	0,420	0,420	0,550
N.2	AL <10%	220	260	0,150	0,250	0,250	0,380	0,380	0,420	0,420	0,550
N.3	AL >10%	90	110	0,150	0,220	0,220	0,300	0,300	0,400	0,400	0,500
N.4	Ms, Cu, Bronze, Rotguss	90	110	0,150	0,220	0,220	0,300	0,300	0,400	0,400	0,500
N.5	Duro-Thermoplast										
N.6	Grafit, GFK										
S.1	Titan										
S.2	Nickel										
H.1	45-52 HRC										
H.2	52-60 HRC										
H.3	60-65 HRC										

BV-H51002

VHM-SPIRALBOHRER 5XD MIT INNENKÜHLUNG

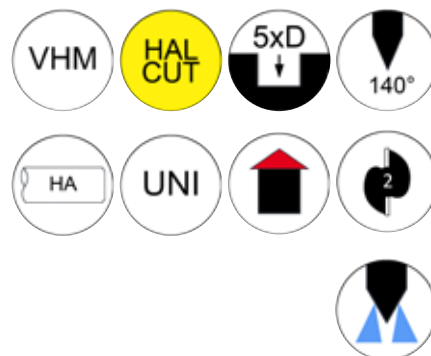
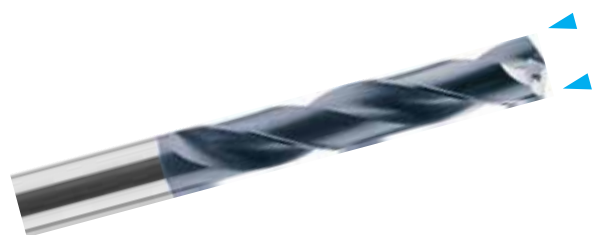

Artikel-Nr. Article-No.	D1 m7	D2 h6	L2	L1	Preis/Euro Price/Euro
BV-H51002.0100B.5D	1,00	3	10	55	53,50 €
BV-H51002.0110B.5D	1,10	3	12	55	53,50 €
BV-H51002.0120B.5D	1,20	3	12	55	53,50 €
BV-H51002.0130B.5D	1,30	3	12	55	53,50 €
BV-H51002.0140B.5D	1,40	3	12	55	53,50 €
BV-H51002.0150B.5D	1,50	3	12	55	53,50 €
BV-H51002.0160B.5D	1,60	3	16	55	53,50 €
BV-H51002.0170B.5D	1,70	3	16	55	53,50 €
BV-H51002.0180B.5D	1,80	3	16	55	53,50 €
BV-H51002.0190B.5D	1,90	3	16	55	53,50 €
BV-H51002.0200B.5D	2,00	3	21	57	53,50 €
BV-H51002.0210B.5D	2,10	3	21	57	53,50 €
BV-H51002.0220B.5D	2,20	3	21	57	53,50 €
BV-H51002.0230B.5D	2,30	3	21	57	53,50 €
BV-H51002.0240B.5D	2,40	3	21	57	53,50 €
BV-H51002.0250B.5D	2,50	3	21	57	53,50 €
BV-H51002.0260B.5D	2,60	3	21	57	53,50 €
BV-H51002.0270B.5D	2,70	3	21	57	53,50 €
BV-H51002.0280B.5D	2,80	3	21	57	53,50 €
BV-H51002.0290B.5D	2,90	3	21	57	53,50 €
BV-H51002.0300B.5D	3,00	6	28	66	53,50 €
BV-H51002.0310B.5D	3,10	6	28	66	53,50 €
BV-H51002.0320B.5D	3,20	6	28	66	53,50 €
BV-H51002.0325B.5D	3,25	6	28	66	53,50 €
BV-H51002.0330B.5D	3,30	6	28	66	53,50 €
BV-H51002.0340B.5D	3,40	6	28	66	53,50 €
BV-H51002.0350B.5D	3,50	6	28	66	53,50 €
BV-H51002.0360B.5D	3,60	6	28	66	53,50 €
BV-H51002.0370B.5D	3,70	6	28	66	53,50 €
BV-H51002.0380B.5D	3,80	6	36	74	53,50 €
BV-H51002.0390B.5D	3,90	6	36	74	53,50 €
BV-H51002.0400B.5D	4,00	6	36	74	53,50 €
BV-H51002.0410B.5D	4,10	6	36	74	53,50 €
BV-H51002.0420B.5D	4,20	6	36	74	53,50 €
BV-H51002.0430B.5D	4,30	6	36	74	53,50 €
BV-H51002.0440B.5D	4,40	6	36	74	53,50 €
BV-H51002.0450B.5D	4,50	6	36	74	53,50 €



BV-H51002 VHM-SPIRALBOHRER 5XD MIT INNENKÜHLUNG

BV-H51002.0460B.5D	4,60	6	36	74	53,50 €
BV-H51002.0465B.5D	4,65	6	36	74	53,50 €
BV-H51002.0470B.5D	4,70	6	36	74	53,50 €
BV-H51002.0480B.5D	4,80	6	44	82	53,50 €
BV-H51002.0490B.5D	4,90	6	44	82	53,50 €
BV-H51002.0500B.5D	5,00	6	44	82	53,50 €
BV-H51002.0510B.5D	5,10	6	44	82	53,50 €
BV-H51002.0520B.5D	5,20	6	44	82	53,50 €
BV-H51002.0530B.5D	5,30	6	44	82	53,50 €
BV-H51002.0540B.5D	5,40	6	44	82	53,50 €
BV-H51002.0550B.5D	5,50	6	44	82	53,50 €
BV-H51002.0555B.5D	5,55	6	44	82	53,50 €
BV-H51002.0560B.5D	5,60	6	44	82	53,50 €
BV-H51002.0570B.5D	5,70	6	44	82	53,50 €
BV-H51002.0580B.5D	5,80	6	44	82	53,50 €
BV-H51002.0590B.5D	5,90	6	44	82	53,50 €
BV-H51002.0600B.5D	6,00	6	44	82	53,50 €
BV-H51002.0610B.5D	6,10	8	53	91	61,25 €
BV-H51002.0620B.5D	6,20	8	53	91	61,25 €
BV-H51002.0630B.5D	6,30	8	53	91	61,25 €
BV-H51002.0640B.5D	6,40	8	53	91	61,25 €
BV-H51002.0650B.5D	6,50	8	53	91	61,25 €
BV-H51002.0660B.5D	6,60	8	53	91	61,25 €
BV-H51002.0670B.5D	6,70	8	53	91	61,25 €
BV-H51002.0680B.5D	6,80	8	53	91	61,25 €
BV-H51002.0690B.5D	6,90	8	53	91	61,25 €
BV-H51002.0700B.5D	7,00	8	53	91	61,25 €
BV-H51002.0710B.5D	7,10	8	53	91	61,25 €
BV-H51002.0720B.5D	7,20	8	53	91	61,25 €
BV-H51002.0730B.5D	7,30	8	53	91	61,25 €
BV-H51002.0740B.5D	7,40	8	53	91	61,25 €
BV-H51002.0750B.5D	7,50	8	53	91	61,25 €
BV-H51002.0760B.5D	7,60	8	53	91	61,25 €
BV-H51002.0770B.5D	7,70	8	53	91	61,25 €
BV-H51002.0780B.5D	7,80	8	53	91	61,25 €
BV-H51002.0790B.5D	7,90	8	53	91	61,25 €
BV-H51002.0800B.5D	8,00	8	53	91	61,25 €
BV-H51002.0810B.5D	8,10	10	61	103	77,85 €
BV-H51002.0820B.5D	8,20	10	61	103	77,85 €
BV-H51002.0830B.5D	8,30	10	61	103	77,85 €
BV-H51002.0840B.5D	8,40	10	61	103	77,85 €
BV-H51002.0850B.5D	8,50	10	61	103	77,85 €
BV-H51002.0860B.5D	8,60	10	61	103	77,85 €
BV-H51002.0870B.5D	8,70	10	61	103	77,85 €

**BV-H51002
VHM-SPIRALBOHRER 5XD MIT INNENKÜHLUNG**

BV-H51002.0880B.5D	8,80	10	61	103	77,85 €
BV-H51002.0890B.5D	8,90	10	61	103	77,85 €
BV-H51002.0900B.5D	9,00	10	61	103	77,85 €
BV-H51002.0910B.5D	9,10	10	61	103	77,85 €
BV-H51002.0920B.5D	9,20	10	61	103	77,85 €
BV-H51002.0930B.5D	9,30	10	61	103	77,85 €
BV-H51002.0940B.5D	9,40	10	61	103	77,85 €
BV-H51002.0950B.5D	9,50	10	61	103	77,85 €
BV-H51002.0960B.5D	9,60	10	61	103	77,85 €
BV-H51002.0970B.5D	9,70	10	61	103	77,85 €
BV-H51002.0980B.5D	9,80	10	61	103	77,85 €
BV-H51002.0990B.5D	9,90	10	61	103	77,85 €
BV-H51002.1000B.5D	10,00	10	61	103	77,85 €
BV-H51002.1010B.5D	10,10	12	71	118	100,85 €
BV-H51002.1020B.5D	10,20	12	71	118	100,85 €
BV-H51002.1030B.5D	10,30	12	71	118	100,85 €
BV-H51002.1040B.5D	10,40	12	71	118	100,85 €
BV-H51002.1050B.5D	10,50	12	71	118	100,85 €
BV-H51002.1060B.5D	10,60	12	71	118	100,85 €
BV-H51002.1070B.5D	10,70	12	71	118	100,85 €
BV-H51002.1080B.5D	10,80	12	71	118	100,85 €
BV-H51002.1090B.5D	10,90	12	71	118	100,85 €
BV-H51002.1100B.5D	11,00	12	71	118	100,85 €
BV-H51002.1110B.5D	11,10	12	71	118	100,85 €
BV-H51002.1120B.5D	11,20	12	71	118	100,85 €
BV-H51002.1130B.5D	11,30	12	71	118	100,85 €
BV-H51002.1140B.5D	11,40	12	71	118	100,85 €
BV-H51002.1150B.5D	11,50	12	71	118	100,85 €
BV-H51002.1160B.5D	11,60	12	71	118	100,85 €
BV-H51002.1170B.5D	11,70	12	71	118	100,85 €
BV-H51002.1180B.5D	11,80	12	71	118	100,85 €
BV-H51002.1190B.5D	11,90	12	71	118	100,85 €
BV-H51002.1200B.5D	12,00	12	71	118	100,85 €
BV-H51002.1220B.5D	12,20	14	77	124	128,90 €
BV-H51002.1230B.5D	12,30	14	77	124	128,90 €
BV-H51002.1250B.5D	12,50	14	77	124	128,90 €
BV-H51002.1280B.5D	12,80	14	77	124	128,90 €
BV-H51002.1300B.5D	13,00	14	77	124	128,90 €
BV-H51002.1350B.5D	13,50	14	77	124	128,90 €
BV-H51002.1380B.5D	13,80	14	77	124	128,90 €
BV-H51002.1400B.5D	14,00	14	77	124	128,90 €
BV-H51002.1420B.5D	14,20	16	83	133	156,10 €
BV-H51002.1450B.5D	14,50	16	83	133	156,10 €
BV-H51002.1480B.5D	14,80	16	83	133	156,10 €

**BV-H51002**
VHM-SPIRALBOHRER 5XD MIT INNENKÜHLUNG

BV-H51002.1500B.5D	15,00	16	83	133	156,10 €
BV-H51002.1520B.5D	15,20	16	83	133	156,10 €
BV-H51002.1550B.5D	15,50	16	83	133	156,10 €
BV-H51002.1580B.5D	15,80	16	83	133	156,10 €
BV-H51002.1600B.5D	16,00	16	83	133	156,10 €
BV-H51002.1650B.5D	16,50	18	93	143	241,60 €
BV-H51002.1680B.5D	16,80	18	93	143	241,60 €
BV-H51002.1700B.5D	17,00	18	93	143	241,60 €
BV-H51002.1750B.5D	17,50	18	93	143	241,60 €
BV-H51002.1780B.5D	17,80	18	93	143	241,60 €
BV-H51002.1800B.5D	18,00	18	93	143	241,60 €
BV-H51002.1850B.5D	18,50	20	101	153	266,80 €
BV-H51002.1900B.5D	19,00	20	101	153	266,80 €
BV-H51002.1950B.5D	19,50	20	101	153	266,80 €
BV-H51002.2000B.5D	20,00	20	101	153	266,80 €



BV-H51002

VHM-SPIRALBOHRER 5XD MIT INNENKÜHLUNG

MATERIALBESCHREIBUNG

		Vc m/min von/bis		f mm/U		f mm/U		f mm/U		f mm/U		f mm/U	
				Ø 1,0-3,0 von/bis	Ø 3,0-6,0 von/bis	Ø 6,0-10,0 von/bis	Ø 10,0-16,0 von/bis	Ø 16,0-20,0 von/bis					
P.1	<500N/mm	100	130	0,070	0,120	0,120	0,180	0,180	0,230	0,230	0,270	0,270	0,300
P.2	<650N/mm	100	130	0,070	0,120	0,120	0,180	0,180	0,230	0,230	0,270	0,270	0,300
P.3	<800N/mm	100	130	0,070	0,120	0,120	0,180	0,180	0,230	0,230	0,270	0,270	0,300
P.4	<1000N/mm	90	120	0,070	0,120	0,120	0,180	0,180	0,230	0,230	0,270	0,270	0,300
P.5	<1400N/mm	35	55	0,040	0,060	0,060	0,090	0,090	0,150	0,150	0,200	0,200	0,230
P.6	Einsatz-ST <1000N/mm	80	100	0,060	0,100	0,100	0,160	0,160	0,200	0,200	0,220	0,220	0,250
P.7	Nitrier-ST <1000N/mm	80	100	0,060	0,100	0,100	0,160	0,160	0,200	0,200	0,220	0,220	0,250
P.8	Vergütung-ST 850N/mm	80	100	0,060	0,100	0,100	0,160	0,160	0,200	0,200	0,220	0,220	0,250
P.9	Werkzeug-ST 1000N/mm	50	80	0,050	0,100	0,100	0,160	0,160	0,200	0,200	0,220	0,220	0,250
M.1	VA <750N/mm	40	60	0,030	0,050	0,080	0,120	0,120	0,160	0,160	0,200	0,200	0,250
M.2	VA >750N/mm	40	60	0,030	0,050	0,080	0,120	0,120	0,160	0,160	0,200	0,200	0,250
K.1	Gusseisen <200HB	100	120	0,030	0,060	0,060	0,130	0,130	0,170	0,170	0,220	0,220	0,300
K.2	Temperguss	100	120	0,030	0,060	0,060	0,130	0,130	0,170	0,170	0,220	0,220	0,300
K.3	Gusseisen mit Kugelgrafit	80	110	0,030	0,060	0,060	0,130	0,130	0,170	0,170	0,220	0,220	0,300
N.1	AL <5%	220	260	0,100	0,150	0,150	0,250	0,250	0,380	0,380	0,420	0,420	0,550
N.2	AL <10%	220	260	0,100	0,150	0,150	0,250	0,250	0,380	0,380	0,420	0,420	0,550
N.3	AL >10%	90	110	0,100	0,150	0,150	0,220	0,220	0,300	0,300	0,400	0,400	0,500
N.4	Ms, Cu, Bronze, Rotguss												
N.5	Duro-Thermoplast												
N.6	Grafit, GFK												
S.1	Titan												
S.2	Nickel												
H.1	45-52 HRC												
H.2	52-60 HRC												
H.3	60-65 HRC												



BV-D00338/BV-DB0338

UNBESCHICHTET UND BESCHICHTET

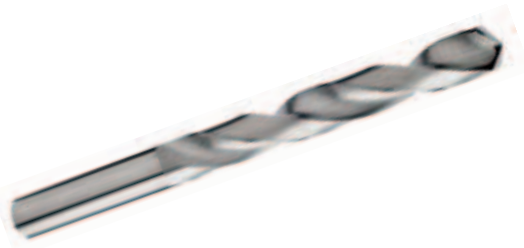
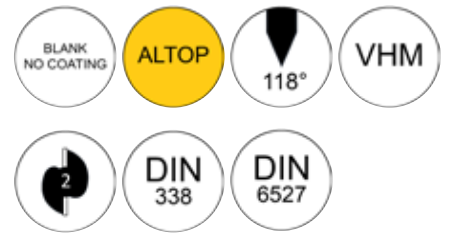

Artikel-Nr. unbeschichtet	Artikel-Nr. beschichtet	D1	D2	L2	L1	Preis/Euro unbeschichtet	Preis/Euro beschichtet
BV-D00338.0050U.00	BV-DB0338.0050B.00	0,50	0,50	7,00	22,00	5,74 €	9,13 €
BV-D00338.0055U.00	BV-DB0338.0055B.00	0,55	0,55	8,00	24,00	5,74 €	9,13 €
BV-D00338.0060U.00	BV-DB0338.0060B.00	0,60	0,60	8,00	24,00	5,74 €	9,13 €
BV-D00338.0065U.00	BV-DB0338.0065B.00	0,65	0,65	9,00	26,00	5,74 €	9,13 €
BV-D00338.0070U.00	BV-DB0338.0070B.00	0,70	0,70	10,00	28,00	5,74 €	9,13 €
BV-D00338.0075U.00	BV-DB0338.0075B.00	0,75	0,75	10,00	28,00	5,74 €	9,13 €
BV-D00338.0080U.00	BV-DB0338.0080B.00	0,80	0,80	11,00	30,00	5,74 €	9,13 €
BV-D00338.0085U.00	BV-DB0338.0085B.00	0,85	0,85	11,00	30,00	5,74 €	9,13 €
BV-D00338.0090U.00	BV-DB0338.0090B.00	0,90	0,90	12,00	32,00	5,74 €	9,13 €
BV-D00338.0095U.00	BV-DB0338.0095B.00	0,95	0,95	12,00	32,00	5,74 €	9,13 €
BV-D00338.0100U.00	BV-DB0338.0100B.00	1,00	1,00	13,00	34,00	5,74 €	9,13 €
BV-D00338.0105U.00	BV-DB0338.0105B.00	1,05	1,05	13,00	34,00	5,74 €	9,13 €
BV-D00338.0110U.00	BV-DB0338.0110B.00	1,10	1,10	15,00	36,00	5,74 €	9,13 €
BV-D00338.0115U.00	BV-DB0338.0115B.00	1,15	1,15	15,00	36,00	5,74 €	9,13 €
BV-D00338.0120U.00	BV-DB0338.0120B.00	1,20	1,20	17,00	38,00	5,74 €	9,13 €
BV-D00338.0125U.00	BV-DB0338.0125B.00	1,25	1,25	17,00	38,00	5,74 €	9,13 €
BV-D00338.0130U.00	BV-DB0338.0130B.00	1,30	1,30	17,00	38,00	5,74 €	9,13 €
BV-D00338.0135U.00	BV-DB0338.0135B.00	1,35	1,35	19,00	40,00	5,74 €	9,13 €
BV-D00338.0140U.00	BV-DB0338.0140B.00	1,40	1,40	19,00	40,00	5,74 €	9,13 €
BV-D00338.0145U.00	BV-DB0338.0145B.00	1,45	1,45	19,00	40,00	5,74 €	9,13 €
BV-D00338.0150U.00	BV-DB0338.0150B.00	1,50	1,50	19,00	40,00	5,74 €	9,13 €
BV-D00338.0155U.00	BV-DB0338.0155B.00	1,55	1,55	21,00	43,00	5,74 €	9,13 €
BV-D00338.0160U.00	BV-DB0338.0160B.00	1,60	1,60	21,00	43,00	5,74 €	9,13 €
BV-D00338.0165U.00	BV-DB0338.0165B.00	1,65	1,65	21,00	43,00	5,74 €	9,13 €
BV-D00338.0170U.00	BV-DB0338.0170B.00	1,70	1,70	21,00	43,00	5,74 €	9,13 €
BV-D00338.0175U.00	BV-DB0338.0175B.00	1,75	1,75	23,00	46,00	5,74 €	9,13 €
BV-D00338.0180U.00	BV-DB0338.0180B.00	1,80	1,80	23,00	46,00	5,74 €	9,13 €
BV-D00338.0185U.00	BV-DB0338.0185B.00	1,85	1,85	23,00	46,00	5,74 €	9,13 €
BV-D00338.0190U.00	BV-DB0338.0190B.00	1,90	1,90	23,00	46,00	5,74 €	9,13 €
BV-D00338.0195U.00	BV-DB0338.0195B.00	1,95	1,95	25,00	49,00	5,74 €	9,13 €
BV-D00338.0200U.00	BV-DB0338.0200B.00	2,00	2,00	25,00	49,00	5,74 €	9,13 €
BV-D00338.0205U.00	BV-DB0338.0205B.00	2,05	2,05	25,00	49,00	6,59 €	9,98 €
BV-D00338.0210U.00	BV-DB0338.0210B.00	2,10	2,10	25,00	49,00	6,59 €	9,98 €
BV-D00338.0215U.00	BV-DB0338.0215B.00	2,15	2,15	28,00	53,00	6,59 €	10,12 €
BV-D00338.0220U.00	BV-DB0338.0220B.00	2,20	2,20	28,00	53,00	6,59 €	10,12 €
BV-D00338.0225U.00	BV-DB0338.0225B.00	2,25	2,25	28,00	53,00	6,59 €	10,12 €



BV-D00338/BV-DB0338 UNBESCHICHTET UND BESCHICHTET

BV-D00338.0230U.00	BV-DB0338.0230B.00	2,30	2,30	28,00	53,00	6,59 €	10,12 €
BV-D00338.0235U.00	BV-DB0338.0235B.00	2,35	2,35	28,00	53,00	6,59 €	10,12 €
BV-D00338.0240U.00	BV-DB0338.0240B.00	2,40	2,40	31,00	57,00	6,59 €	10,12 €
BV-D00338.0245U.00	BV-DB0338.0245B.00	2,45	2,45	31,00	57,00	7,63 €	11,16 €
BV-D00338.0250U.00	BV-DB0338.0250B.00	2,50	2,50	31,00	57,00	7,63 €	11,16 €
BV-D00338.0255U.00	BV-DB0338.0255B.00	2,55	2,55	31,00	57,00	7,63 €	11,16 €
BV-D00338.0260U.00	BV-DB0338.0260B.00	2,60	2,60	31,00	57,00	7,63 €	11,16 €
BV-D00338.0265U.00	BV-DB0338.0265B.00	2,65	2,65	31,00	57,00	7,63 €	11,16 €
BV-D00338.0270U.00	BV-DB0338.0270B.00	2,70	2,70	34,00	61,00	7,63 €	11,16 €
BV-D00338.0275U.00	BV-DB0338.0275B.00	2,75	2,75	34,00	61,00	7,63 €	11,16 €
BV-D00338.0280U.00	BV-DB0338.0280B.00	2,80	2,80	34,00	61,00	7,63 €	11,16 €
BV-D00338.0285U.00	BV-DB0338.0285B.00	2,85	2,85	34,00	61,00	7,63 €	11,16 €
BV-D00338.0290U.00	BV-DB0338.0290B.00	2,90	2,90	34,00	61,00	7,63 €	11,16 €
BV-D00338.0295U.00	BV-DB0338.0295B.00	2,95	2,95	34,00	61,00	7,63 €	11,16 €
BV-D00338.0300U.00	BV-DB0338.0300B.00	3,00	3,00	34,00	61,00	7,63 €	11,16 €
BV-D00338.0305U.00	BV-DB0338.0305B.00	3,05	3,05	37,00	65,00	10,26 €	13,80 €
BV-D00338.0310U.00	BV-DB0338.0310B.00	3,10	3,10	37,00	65,00	10,26 €	13,80 €
BV-D00338.0315U.00	BV-DB0338.0315B.00	3,15	3,15	37,00	65,00	10,26 €	13,80 €
BV-D00338.0320U.00	BV-DB0338.0320B.00	3,20	3,20	37,00	65,00	10,26 €	13,80 €
BV-D00338.0325U.00	BV-DB0338.0325B.00	3,25	3,25	37,00	65,00	10,26 €	13,80 €
BV-D00338.0330U.00	BV-DB0338.0330B.00	3,30	3,30	37,00	65,00	10,26 €	13,80 €
BV-D00338.0335U.00	BV-DB0338.0335B.00	3,35	3,35	37,00	65,00	10,26 €	13,80 €
BV-D00338.0340U.00	BV-DB0338.0340B.00	3,40	3,40	40,00	70,00	10,26 €	13,80 €
BV-D00338.0345U.00	BV-DB0338.0345B.00	3,45	3,45	40,00	70,00	10,26 €	13,80 €
BV-D00338.0350U.00	BV-DB0338.0350B.00	3,50	3,50	40,00	70,00	10,26 €	13,80 €
BV-D00338.0355U.00	BV-DB0338.0355B.00	3,55	3,55	40,00	70,00	11,49 €	15,02 €
BV-D00338.0360U.00	BV-DB0338.0360B.00	3,60	3,60	40,00	70,00	11,49 €	15,02 €
BV-D00338.0365U.00	BV-DB0338.0365B.00	3,65	3,65	40,00	70,00	11,49 €	15,02 €
BV-D00338.0370U.00	BV-DB0338.0370B.00	3,70	3,70	40,00	70,00	11,49 €	15,02 €
BV-D00338.0375U.00	BV-DB0338.0375B.00	3,75	3,75	40,00	70,00	11,49 €	15,02 €
BV-D00338.0380U.00	BV-DB0338.0380B.00	3,80	3,80	44,00	75,00	11,49 €	15,02 €
BV-D00338.0385U.00	BV-DB0338.0385B.00	3,85	3,85	44,00	75,00	11,49 €	15,02 €
BV-D00338.0390U.00	BV-DB0338.0390B.00	3,90	3,90	44,00	75,00	11,49 €	15,02 €
BV-D00338.0395U.00	BV-DB0338.0395B.00	3,95	3,95	44,00	75,00	11,49 €	15,02 €
BV-D00338.0400U.00	BV-DB0338.0400B.00	4,00	4,00	44,00	75,00	11,49 €	15,02 €
BV-D00338.0405U.00	BV-DB0338.0405B.00	4,05	4,05	44,00	75,00	15,21 €	18,85 €
BV-D00338.0410U.00	BV-DB0338.0410B.00	4,10	4,10	44,00	75,00	15,21 €	18,85 €
BV-D00338.0415U.00	BV-DB0338.0415B.00	4,15	4,15	44,00	75,00	15,21 €	18,85 €
BV-D00338.0420U.00	BV-DB0338.0420B.00	4,20	4,20	44,00	75,00	15,21 €	18,85 €
BV-D00338.0425U.00	BV-DB0338.0425B.00	4,25	4,25	44,00	75,00	15,21 €	18,85 €
BV-D00338.0430U.00	BV-DB0338.0430B.00	4,30	4,30	48,00	80,00	15,21 €	18,96 €
BV-D00338.0435U.00	BV-DB0338.0435B.00	4,35	4,35	48,00	80,00	15,21 €	18,96 €
BV-D00338.0440U.00	BV-DB0338.0440B.00	4,40	4,40	48,00	80,00	15,21 €	18,96 €
BV-D00338.0445U.00	BV-DB0338.0445B.00	4,45	4,45	48,00	80,00	15,21 €	18,96 €



BV-D00338/BV-DB0338 UNBESCHICHTET UND BESCHICHTET

BV-D00338.0450U.00	BV-DB0338.0450B.00	4,50	4,50	48,00	80,00	15,21 €	18,96 €
BV-D00338.0455U.00	BV-DB0338.0455B.00	4,55	4,55	48,00	80,00	18,36 €	22,11 €
BV-D00338.0460U.00	BV-DB0338.0460B.00	4,60	4,60	48,00	80,00	18,36 €	22,11 €
BV-D00338.0465U.00	BV-DB0338.0465B.00	4,65	4,65	48,00	80,00	18,36 €	22,11 €
BV-D00338.0470U.00	BV-DB0338.0470B.00	4,70	4,70	48,00	80,00	18,36 €	22,11 €
BV-D00338.0475U.00	BV-DB0338.0475B.00	4,75	4,75	48,00	80,00	18,36 €	22,11 €
BV-D00338.0480U.00	BV-DB0338.0480B.00	4,80	4,80	53,00	86,00	18,36 €	22,11 €
BV-D00338.0485U.00	BV-DB0338.0485B.00	4,85	4,85	53,00	86,00	18,36 €	22,11 €
BV-D00338.0490U.00	BV-DB0338.0490B.00	4,90	4,90	53,00	86,00	18,36 €	22,11 €
BV-D00338.0495U.00	BV-DB0338.0495B.00	4,95	4,95	53,00	86,00	18,36 €	22,11 €
BV-D00338.0500U.00	BV-DB0338.0500B.00	5,00	5,00	53,00	86,00	18,36 €	22,11 €
BV-D00338.0505U.00	BV-DB0338.0505B.00	5,05	5,05	53,00	86,00	20,42 €	24,17 €
BV-D00338.0510U.00	BV-DB0338.0510B.00	5,10	5,10	53,00	86,00	20,44 €	24,18 €
BV-D00338.0515U.00	BV-DB0338.0515B.00	5,15	5,15	53,00	86,00	20,44 €	24,18 €
BV-D00338.0520U.00	BV-DB0338.0520B.00	5,20	5,20	53,00	86,00	20,44 €	24,18 €
BV-D00338.0525U.00	BV-DB0338.0525B.00	5,25	5,25	53,00	86,00	20,44 €	24,18 €
BV-D00338.0530U.00	BV-DB0338.0530B.00	5,30	5,30	53,00	86,00	20,44 €	24,18 €
BV-D00338.0535U.00	BV-DB0338.0535B.00	5,35	5,35	58,00	93,00	20,44 €	24,18 €
BV-D00338.0540U.00	BV-DB0338.0540B.00	5,40	5,40	58,00	93,00	20,44 €	24,18 €
BV-D00338.0545U.00	BV-DB0338.0545B.00	5,45	5,45	58,00	93,00	20,44 €	24,18 €
BV-D00338.0550U.00	BV-DB0338.0550B.00	5,50	5,50	58,00	93,00	20,44 €	24,18 €
BV-D00338.0555U.00	BV-DB0338.0555B.00	5,55	5,55	58,00	93,00	24,39 €	28,14 €
BV-D00338.0560U.00	BV-DB0338.0560B.00	5,60	5,60	58,00	93,00	24,39 €	28,14 €
BV-D00338.0565U.00	BV-DB0338.0565B.00	5,65	5,65	58,00	93,00	24,39 €	28,14 €
BV-D00338.0570U.00	BV-DB0338.0570B.00	5,70	5,70	58,00	93,00	24,39 €	28,14 €
BV-D00338.0575U.00	BV-DB0338.0575B.00	5,75	5,75	58,00	93,00	24,39 €	28,14 €
BV-D00338.0580U.00	BV-DB0338.0580B.00	5,80	5,80	58,00	93,00	24,39 €	28,14 €
BV-D00338.0585U.00	BV-DB0338.0585B.00	5,85	5,85	58,00	93,00	24,39 €	28,14 €
BV-D00338.0590U.00	BV-DB0338.0590B.00	5,90	5,90	58,00	93,00	24,39 €	28,14 €
BV-D00338.0595U.00	BV-DB0338.0595B.00	5,95	5,95	58,00	93,00	24,39 €	28,14 €
BV-D00338.0600U.00	BV-DB0338.0600B.00	6,00	6,00	58,00	93,00	24,39 €	28,14 €
BV-D00338.0605U.00	BV-DB0338.0605B.00	6,05	6,05	64,00	101,00	28,11 €	32,11 €
BV-D00338.0610U.00	BV-DB0338.0610B.00	6,10	6,10	64,00	101,00	28,11 €	32,11 €
BV-D00338.0615U.00	BV-DB0338.0615B.00	6,15	6,15	64,00	101,00	28,11 €	32,11 €
BV-D00338.0620U.00	BV-DB0338.0620B.00	6,20	6,20	64,00	101,00	28,11 €	32,11 €
BV-D00338.0625U.00	BV-DB0338.0625B.00	6,25	6,25	64,00	101,00	28,11 €	32,11 €
BV-D00338.0630U.00	BV-DB0338.0630B.00	6,30	6,30	64,00	101,00	28,11 €	32,11 €
BV-D00338.0635U.00	BV-DB0338.0635B.00	6,35	6,35	64,00	101,00	28,11 €	32,11 €
BV-D00338.0640U.00	BV-DB0338.0640B.00	6,40	6,40	64,00	101,00	28,11 €	32,11 €
BV-D00338.0645U.00	BV-DB0338.0645B.00	6,45	6,45	64,00	101,00	28,11 €	32,11 €
BV-D00338.0650U.00	BV-DB0338.0650B.00	6,50	6,50	64,00	101,00	28,11 €	32,11 €
BV-D00338.0655U.00	BV-DB0338.0655B.00	6,55	6,55	64,00	101,00	35,08 €	39,08 €
BV-D00338.0660U.00	BV-DB0338.0660B.00	6,60	6,60	64,00	101,00	35,08 €	39,08 €
BV-D00338.0665U.00	BV-DB0338.0665B.00	6,65	6,65	64,00	101,00	35,08 €	39,08 €



BV-D00338/BV-DB0338 UNBESCHICHTET UND BESCHICHTET

BV-D00338.0670U.00	BV-DB0338.0670B.00	6,70	6,70	64,00	101,00	35,08 €	39,08 €
BV-D00338.0675U.00	BV-DB0338.0675B.00	6,75	6,75	70,00	109,00	35,08 €	39,08 €
BV-D00338.0680U.00	BV-DB0338.0680B.00	6,80	6,80	70,00	109,00	35,08 €	39,08 €
BV-D00338.0685U.00	BV-DB0338.0685B.00	6,85	6,85	70,00	109,00	35,08 €	39,08 €
BV-D00338.0690U.00	BV-DB0338.0690B.00	6,90	6,90	70,00	109,00	35,08 €	39,08 €
BV-D00338.0695U.00	BV-DB0338.0695B.00	6,95	6,95	70,00	109,00	35,08 €	39,08 €
BV-D00338.0700U.00	BV-DB0338.0700B.00	7,00	7,00	70,00	109,00	35,08 €	39,08 €
BV-D00338.0705U.00	BV-DB0338.0705B.00	7,05	7,05	70,00	109,00	39,98 €	43,98 €
BV-D00338.0710U.00	BV-DB0338.0710B.00	7,10	7,10	70,00	109,00	39,98 €	43,98 €
BV-D00338.0715U.00	BV-DB0338.0715B.00	7,15	7,15	70,00	109,00	39,98 €	43,98 €
BV-D00338.0720U.00	BV-DB0338.0720B.00	7,20	7,20	70,00	109,00	39,98 €	43,98 €
BV-D00338.0725U.00	BV-DB0338.0725B.00	7,25	7,25	70,00	109,00	39,98 €	43,98 €
BV-D00338.0730U.00	BV-DB0338.0730B.00	7,30	7,30	70,00	109,00	39,98 €	43,98 €
BV-D00338.0735U.00	BV-DB0338.0735B.00	7,35	7,35	70,00	109,00	39,98 €	43,98 €
BV-D00338.0740U.00	BV-DB0338.0740B.00	7,40	7,40	70,00	109,00	39,98 €	43,98 €
BV-D00338.0745U.00	BV-DB0338.0745B.00	7,45	7,45	70,00	109,00	39,98 €	43,98 €
BV-D00338.0750U.00	BV-DB0338.0750B.00	7,50	7,50	70,00	109,00	39,98 €	43,98 €
BV-D00338.0755U.00	BV-DB0338.0755B.00	7,55	7,55	76,00	117,00	48,07 €	52,08 €
BV-D00338.0760U.00	BV-DB0338.0760B.00	7,60	7,60	76,00	117,00	48,07 €	52,08 €
BV-D00338.0765U.00	BV-DB0338.0765B.00	7,65	7,65	76,00	117,00	48,07 €	52,08 €
BV-D00338.0770U.00	BV-DB0338.0770B.00	7,70	7,70	76,00	117,00	48,07 €	52,08 €
BV-D00338.0775U.00	BV-DB0338.0775B.00	7,75	7,75	76,00	117,00	48,07 €	52,08 €
BV-D00338.0780U.00	BV-DB0338.0780B.00	7,80	7,80	76,00	117,00	48,07 €	52,08 €
BV-D00338.0785U.00	BV-DB0338.0785B.00	7,85	7,85	76,00	117,00	48,07 €	52,08 €
BV-D00338.0790U.00	BV-DB0338.0790B.00	7,90	7,90	76,00	117,00	48,07 €	52,08 €
BV-D00338.0795U.00	BV-DB0338.0795B.00	7,95	7,95	76,00	117,00	48,07 €	52,08 €
BV-D00338.0800U.00	BV-DB0338.0800B.00	8,00	8,00	76,00	117,00	48,07 €	52,08 €
BV-D00338.0805U.00	BV-DB0338.0805B.00	8,05	8,05	76,00	117,00	54,01 €	58,70 €
BV-D00338.0810U.00	BV-DB0338.0810B.00	8,10	8,10	76,00	117,00	54,01 €	58,70 €
BV-D00338.0815U.00	BV-DB0338.0815B.00	8,15	8,15	76,00	117,00	54,01 €	58,70 €
BV-D00338.0820U.00	BV-DB0338.0820B.00	8,20	8,20	76,00	117,00	54,01 €	58,70 €
BV-D00338.0825U.00	BV-DB0338.0825B.00	8,25	8,25	76,00	117,00	54,01 €	58,70 €
BV-D00338.0830U.00	BV-DB0338.0830B.00	8,30	8,30	76,00	117,00	54,01 €	58,70 €
BV-D00338.0835U.00	BV-DB0338.0835B.00	8,35	8,35	76,00	117,00	54,01 €	58,70 €
BV-D00338.0840U.00	BV-DB0338.0840B.00	8,40	8,40	76,00	117,00	54,01 €	58,70 €
BV-D00338.0845U.00	BV-DB0338.0845B.00	8,45	8,45	76,00	117,00	54,01 €	58,70 €
BV-D00338.0850U.00	BV-DB0338.0850B.00	8,50	8,50	76,00	117,00	54,01 €	58,70 €
BV-D00338.0855U.00	BV-DB0338.0855B.00	8,55	8,55	82,00	125,00	64,23 €	68,92 €
BV-D00338.0860U.00	BV-DB0338.0860B.00	8,60	8,60	82,00	125,00	64,23 €	68,92 €
BV-D00338.0865U.00	BV-DB0338.0865B.00	8,65	8,65	82,00	125,00	64,23 €	68,92 €
BV-D00338.0870U.00	BV-DB0338.0870B.00	8,70	8,70	82,00	125,00	64,23 €	68,92 €
BV-D00338.0875U.00	BV-DB0338.0875B.00	8,75	8,75	82,00	125,00	64,23 €	68,92 €
BV-D00338.0880U.00	BV-DB0338.0880B.00	8,80	8,80	82,00	125,00	64,23 €	68,92 €
BV-D00338.0885U.00	BV-DB0338.0885B.00	8,85	8,85	82,00	125,00	64,23 €	68,92 €



BV-D00338/BV-DB0338 UNBESCHICHTET UND BESCHICHTET

BV-D00338.0890U.00	BV-DB0338.0890B.00	8,90	8,90	82,00	125,00	64,23 €	68,92 €
BV-D00338.0895U.00	BV-DB0338.0895B.00	8,95	8,95	82,00	125,00	64,23 €	68,92 €
BV-D00338.0900U.00	BV-DB0338.0900B.00	9,00	9,00	82,00	125,00	64,23 €	68,92 €
BV-D00338.0905U.00	BV-DB0338.0905B.00	9,05	9,05	82,00	125,00	80,28 €	84,98 €
BV-D00338.0910U.00	BV-DB0338.0910B.00	9,10	9,10	82,00	125,00	80,28 €	84,98 €
BV-D00338.0915U.00	BV-DB0338.0915B.00	9,15	9,15	82,00	125,00	80,28 €	84,98 €
BV-D00338.0920U.00	BV-DB0338.0920B.00	9,20	9,20	82,00	125,00	80,28 €	84,98 €
BV-D00338.0925U.00	BV-DB0338.0925B.00	9,25	9,25	82,00	125,00	80,28 €	84,98 €
BV-D00338.0930U.00	BV-DB0338.0930B.00	9,30	9,30	82,00	125,00	80,28 €	84,98 €
BV-D00338.0935U.00	BV-DB0338.0935B.00	9,35	9,35	82,00	125,00	80,28 €	84,98 €
BV-D00338.0940U.00	BV-DB0338.0940B.00	9,40	9,40	82,00	125,00	80,28 €	84,98 €
BV-D00338.0945U.00	BV-DB0338.0945B.00	9,45	9,45	82,00	125,00	80,28 €	84,98 €
BV-D00338.0950U.00	BV-DB0338.0950B.00	9,50	9,50	82,00	125,00	80,28 €	84,98 €
BV-D00338.0955U.00	BV-DB0338.0955B.00	9,55	9,55	88,00	133,00	80,28 €	84,98 €
BV-D00338.0960U.00	BV-DB0338.0960B.00	9,60	9,60	88,00	133,00	80,28 €	84,98 €
BV-D00338.0965U.00	BV-DB0338.0965B.00	9,65	9,65	88,00	133,00	80,28 €	84,98 €
BV-D00338.0970U.00	BV-DB0338.0970B.00	9,70	9,70	88,00	133,00	80,28 €	84,98 €
BV-D00338.0975U.00	BV-DB0338.0975B.00	9,75	9,75	88,00	133,00	80,28 €	84,98 €
BV-D00338.0980U.00	BV-DB0338.0980B.00	9,80	9,80	88,00	133,00	80,28 €	84,98 €
BV-D00338.0985U.00	BV-DB0338.0985B.00	9,85	9,85	88,00	133,00	80,28 €	84,98 €
BV-D00338.0990U.00	BV-DB0338.0990B.00	9,90	9,90	88,00	133,00	80,28 €	84,98 €
BV-D00338.0995U.00	BV-DB0338.0995B.00	9,95	9,95	88,00	133,00	91,63 €	96,32 €
BV-D00338.1000U.00	BV-DB0338.1000B.00	10,00	10,00	88,00	133,00	91,63 €	96,32 €
BV-D00338.1005U.00	BV-DB0338.1005B.00	10,05	10,05	88,00	133,00	91,63 €	96,69 €
BV-D00338.1010U.00	BV-DB0338.1010B.00	10,10	10,10	88,00	133,00	91,63 €	96,69 €
BV-D00338.1015U.00	BV-DB0338.1015B.00	10,15	10,15	88,00	133,00	91,63 €	96,69 €
BV-D00338.1020U.00	BV-DB0338.1020B.00	10,20	10,20	88,00	133,00	91,63 €	96,69 €
BV-D00338.1025U.00	BV-DB0338.1025B.00	10,25	10,25	88,00	133,00	91,63 €	96,69 €
BV-D00338.1030U.00	BV-DB0338.1030B.00	10,30	10,30	88,00	133,00	91,63 €	96,69 €
BV-D00338.1035U.00	BV-DB0338.1035B.00	10,35	10,35	88,00	133,00	91,63 €	96,69 €
BV-D00338.1040U.00	BV-DB0338.1040B.00	10,40	10,40	88,00	133,00	91,63 €	96,69 €
BV-D00338.1045U.00	BV-DB0338.1045B.00	10,45	10,45	88,00	133,00	98,79 €	103,85 €
BV-D00338.1050U.00	BV-DB0338.1050B.00	10,50	10,50	88,00	133,00	98,79 €	103,85 €
BV-D00338.1055U.00	BV-DB0338.1055B.00	10,55	10,55	88,00	133,00	98,79 €	103,85 €
BV-D00338.1060U.00	BV-DB0338.1060B.00	10,60	10,60	88,00	133,00	98,79 €	103,85 €
BV-D00338.1065U.00	BV-DB0338.1065B.00	10,65	10,65	95,00	142,00	98,79 €	103,85 €
BV-D00338.1070U.00	BV-DB0338.1070B.00	10,70	10,70	95,00	142,00	98,79 €	103,85 €
BV-D00338.1075U.00	BV-DB0338.1075B.00	10,75	10,75	95,00	142,00	98,79 €	103,85 €
BV-D00338.1080U.00	BV-DB0338.1080B.00	10,80	10,80	95,00	142,00	98,79 €	103,85 €
BV-D00338.1085U.00	BV-DB0338.1085B.00	10,85	10,85	95,00	142,00	98,79 €	103,85 €
BV-D00338.1090U.00	BV-DB0338.1090B.00	10,90	10,90	95,00	142,00	98,79 €	103,85 €
BV-D00338.1095U.00	BV-DB0338.1095B.00	10,95	10,95	95,00	142,00	108,44 €	113,50 €
BV-D00338.1100U.00	BV-DB0338.1100B.00	11,00	11,00	95,00	142,00	108,44 €	113,50 €
BV-D00338.1105U.00	BV-DB0338.1105B.00	11,05	11,05	95,00	142,00	108,44 €	113,50 €



BV-D00338/BV-DB0338 UNBESCHICHTET UND BESCHICHTET

BV-D00338.1110U.00	BV-DB0338.1110B.00	11,10	11,10	95,00	142,00	108,44 €	113,50 €
BV-D00338.1115U.00	BV-DB0338.1115B.00	11,15	11,15	95,00	142,00	108,44 €	113,50 €
BV-D00338.1120U.00	BV-DB0338.1120B.00	11,20	11,20	95,00	142,00	108,44 €	113,50 €
BV-D00338.1125U.00	BV-DB0338.1125B.00	11,25	11,25	95,00	142,00	108,44 €	113,50 €
BV-D00338.1130U.00	BV-DB0338.1130B.00	11,30	11,30	95,00	142,00	108,44 €	113,50 €
BV-D00338.1135U.00	BV-DB0338.1135B.00	11,35	11,35	95,00	142,00	108,44 €	113,50 €
BV-D00338.1140U.00	BV-DB0338.1140B.00	11,40	11,40	95,00	142,00	108,44 €	113,50 €
BV-D00338.1145U.00	BV-DB0338.1145B.00	11,45	11,45	95,00	142,00	120,54 €	125,60 €
BV-D00338.1150U.00	BV-DB0338.1150B.00	11,50	11,50	95,00	142,00	120,54 €	125,60 €
BV-D00338.1155U.00	BV-DB0338.1155B.00	11,55	11,55	95,00	142,00	120,54 €	125,60 €
BV-D00338.1160U.00	BV-DB0338.1160B.00	11,60	11,60	95,00	142,00	120,54 €	125,60 €
BV-D00338.1165U.00	BV-DB0338.1165B.00	11,65	11,65	95,00	142,00	120,54 €	125,60 €
BV-D00338.1170U.00	BV-DB0338.1170B.00	11,70	11,70	95,00	142,00	120,54 €	125,60 €
BV-D00338.1175U.00	BV-DB0338.1175B.00	11,75	11,75	95,00	142,00	120,54 €	125,60 €
BV-D00338.1180U.00	BV-DB0338.1180B.00	11,80	11,80	95,00	142,00	120,54 €	125,60 €
BV-D00338.1185U.00	BV-DB0338.1185B.00	11,85	11,85	102,00	151,00	120,54 €	125,60 €
BV-D00338.1190U.00	BV-DB0338.1190B.00	11,90	11,90	102,00	151,00	120,54 €	125,60 €
BV-D00338.1195U.00	BV-DB0338.1195B.00	11,95	11,95	102,00	151,00	146,01 €	151,07 €
BV-D00338.1200U.00	BV-DB0338.1200B.00	12,00	12,00	102,00	151,00	146,01 €	151,07 €



BV-D00338/BV-DB0338

UNBESCHICHTET UND BESCHICHTET

MATERIALBESCHREIBUNG

			f mm/U		f mm/U		f mm/U		f mm/U		f mm/U		f mm/U	
		Vc m/mm	0,50-2,00		2,00-4,00		4,00-6,00		6,00-8,00		8,00-10,00		10,00-12,00	
P.1	<500N/mm	65	0,030	0,080	0,080	0,120	0,120	0,150	0,150	0,160	0,160	0,200	0,200	0,220
P.2	<650N/mm	65	0,030	0,080	0,080	0,120	0,120	0,150	0,150	0,160	0,160	0,200	0,200	0,220
P.3	<800N/mm	60	0,030	0,080	0,080	0,120	0,120	0,150	0,150	0,160	0,160	0,200	0,200	0,220
P.4	<1000N/mm	50	0,030	0,080	0,080	0,120	0,120	0,150	0,150	0,160	0,160	0,200	0,200	0,220
P.5	<1400N/mm	40	0,030	0,060	0,060	0,100	0,100	0,120	0,120	0,140	0,140	0,160	0,160	2,000
P.6	Einsatz-ST <1000N/mm	50	0,030	0,080	0,080	0,120	0,120	0,150	0,150	0,160	0,160	0,200	0,200	0,220
P.7	Nitrier-ST <1000N/mm	50	0,030	0,080	0,080	0,120	0,120	0,150	0,150	0,160	0,160	0,200	0,200	0,220
P.8	Vergütung-ST 850N/mm	60	0,030	0,060	0,060	0,100	0,100	0,120	0,120	0,140	0,140	0,160	0,160	2,000
P.9	Werkzeug-ST 1000N/mm	40	0,030	0,080	0,080	0,120	0,120	0,150	0,150	0,160	0,160	0,200	0,200	0,220
M.1	VA <750N/mm	30	0,030	0,060	0,060	0,100	0,100	0,120	0,120	0,140	0,140	0,160	0,160	2,000
M.2	VA >750N/mm	20	0,030	0,060	0,060	0,100	0,100	0,120	0,120	0,140	0,140	0,160	0,160	2,000
K.1	Gusseisen <200HB	75	0,030	0,080	0,080	0,120	0,120	0,150	0,150	0,160	0,160	0,200	0,200	0,220
K.2	Temperguss	75	0,030	0,080	0,080	0,120	0,120	0,150	0,150	0,160	0,160	0,200	0,200	0,220
K.3	Gusseisen mit Kugelgraphit	70	0,030	0,060	0,060	0,100	0,100	0,120	0,120	0,140	0,140	0,160	0,160	2,000
N.1	AL <5%	180	0,070	0,100	0,100	0,150	0,150	0,200	0,200	0,250	0,250	0,280	0,280	0,300
N.2	AL <10%	170	0,070	0,100	0,100	0,150	0,150	0,200	0,200	0,250	0,250	0,280	0,280	0,300
N.3	AL >10%	160	0,060	0,080	0,080	0,130	0,130	0,180	0,180	0,220	0,220	0,250	0,250	0,280
N.4	Ms, Cu, Bronze, Rotguss	160	0,070	0,100	0,100	0,150	0,150	0,200	0,200	0,250	0,250	0,280	0,280	0,300
N.5	Duro-Thermoplast													
N.6	Grafit, GFK													
S.1	Titan													
S.2	Nickel													
H.1	45-52 HRC													
H.2	52-60 HRC													
H.3	60-65 HRC													

BV-D01897/BV-DB1897 UNBESCHICHTET UND BESCHICHTET

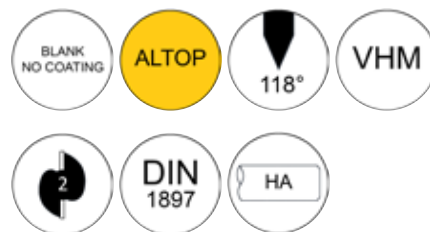

Artikel-Nr. unbeschichtet	Artikel-Nr. beschichtet	D1	D2	L2	L1	Preis/Euro unbeschichtet	Preis/Euro beschichtet
BV-D01897.0050U.00	BV-DB1897.0050B.00	0,50	0,50	5,00	22,00	5,47 €	8,85 €
BV-D01897.0055U.00	BV-DB1897.0055B.00	0,55	0,55	5,00	22,00	5,47 €	8,85 €
BV-D01897.0060U.00	BV-DB1897.0060B.00	0,60	0,60	5,00	22,00	5,47 €	8,85 €
BV-D01897.0065U.00	BV-DB1897.0065B.00	0,65	0,65	5,00	22,00	5,28 €	8,66 €
BV-D01897.0070U.00	BV-DB1897.0070B.00	0,70	0,70	6,00	24,00	5,28 €	8,66 €
BV-D01897.0075U.00	BV-DB1897.0075B.00	0,75	0,75	6,00	24,00	5,28 €	8,66 €
BV-D01897.0080U.00	BV-DB1897.0080B.00	0,80	0,80	6,00	24,00	5,28 €	8,66 €
BV-D01897.0085U.00	BV-DB1897.0085B.00	0,85	0,85	6,00	24,00	5,28 €	8,66 €
BV-D01897.0090U.00	BV-DB1897.0090B.00	0,90	0,90	7,00	26,00	5,28 €	8,66 €
BV-D01897.0095U.00	BV-DB1897.0095B.00	0,95	0,95	7,00	26,00	5,28 €	8,66 €
BV-D01897.0100U.00	BV-DB1897.0100B.00	1,00	1,00	7,00	26,00	5,14 €	8,52 €
BV-D01897.0105U.00	BV-DB1897.0105B.00	1,05	1,05	7,00	26,00	5,14 €	8,52 €
BV-D01897.0110U.00	BV-DB1897.0110B.00	1,10	1,10	8,00	28,00	5,14 €	8,52 €
BV-D01897.0115U.00	BV-DB1897.0115B.00	1,15	1,15	8,00	28,00	5,14 €	8,52 €
BV-D01897.0120U.00	BV-DB1897.0120B.00	1,20	1,20	9,00	30,00	5,14 €	8,52 €
BV-D01897.0125U.00	BV-DB1897.0125B.00	1,25	1,25	9,00	30,00	5,14 €	8,52 €
BV-D01897.0130U.00	BV-DB1897.0130B.00	1,30	1,30	9,00	30,00	5,14 €	8,52 €
BV-D01897.0135U.00	BV-DB1897.0135B.00	1,35	1,35	10,00	32,00	5,14 €	8,52 €
BV-D01897.0140U.00	BV-DB1897.0140B.00	1,40	1,40	10,00	32,00	5,14 €	8,52 €
BV-D01897.0145U.00	BV-DB1897.0145B.00	1,45	1,45	10,00	32,00	5,14 €	8,52 €
BV-D01897.0150U.00	BV-DB1897.0150B.00	1,50	1,50	10,00	32,00	5,14 €	8,52 €
BV-D01897.0155U.00	BV-DB1897.0155B.00	1,55	1,55	11,00	34,00	5,14 €	8,52 €
BV-D01897.0160U.00	BV-DB1897.0160B.00	1,60	1,60	11,00	34,00	5,14 €	8,52 €
BV-D01897.0165U.00	BV-DB1897.0165B.00	1,65	1,65	11,00	34,00	5,14 €	8,52 €
BV-D01897.0170U.00	BV-DB1897.0170B.00	1,70	1,70	11,00	34,00	5,14 €	8,52 €
BV-D01897.0175U.00	BV-DB1897.0175B.00	1,75	1,75	12,00	36,00	5,14 €	8,52 €
BV-D01897.0180U.00	BV-DB1897.0180B.00	1,80	1,80	12,00	36,00	5,14 €	8,52 €
BV-D01897.0185U.00	BV-DB1897.0185B.00	1,85	1,85	12,00	36,00	5,14 €	8,52 €
BV-D01897.0190U.00	BV-DB1897.0190B.00	1,90	1,90	12,00	36,00	5,14 €	8,52 €
BV-D01897.0195U.00	BV-DB1897.0195B.00	1,95	1,95	13,00	38,00	5,14 €	8,52 €
BV-D01897.0200U.00	BV-DB1897.0200B.00	2,00	2,00	13,00	38,00	5,14 €	8,52 €
BV-D01897.0205U.00	BV-DB1897.0205B.00	2,05	2,05	13,00	38,00	5,23 €	8,62 €
BV-D01897.0210U.00	BV-DB1897.0210B.00	2,10	2,10	13,00	38,00	5,23 €	8,62 €
BV-D01897.0215U.00	BV-DB1897.0215B.00	2,15	2,15	14,00	40,00	5,23 €	8,62 €
BV-D01897.0220U.00	BV-DB1897.0220B.00	2,20	2,20	14,00	40,00	5,23 €	8,62 €
BV-D01897.0225U.00	BV-DB1897.0225B.00	2,25	2,25	14,00	40,00	5,23 €	8,62 €

**BV-D01897/BV-DB1897
UNBESCHICHTET UND BESCHICHTET**

BV-D01897.0230U.00	BV-DB1897.0230B.00	2,30	2,30	14,00	40,00	5,23 €	8,62 €
BV-D01897.0235U.00	BV-DB1897.0235B.00	2,35	2,35	14,00	40,00	5,23 €	8,62 €
BV-D01897.0240U.00	BV-DB1897.0240B.00	2,40	2,40	15,00	43,00	5,23 €	8,62 €
BV-D01897.0245U.00	BV-DB1897.0245B.00	2,45	2,45	15,00	43,00	5,80 €	9,19 €
BV-D01897.0250U.00	BV-DB1897.0250B.00	2,50	2,50	15,00	43,00	5,80 €	9,19 €
BV-D01897.0255U.00	BV-DB1897.0255B.00	2,55	2,55	15,00	43,00	5,80 €	9,19 €
BV-D01897.0260U.00	BV-DB1897.0260B.00	2,60	2,60	15,00	43,00	5,80 €	9,19 €
BV-D01897.0265U.00	BV-DB1897.0265B.00	2,65	2,65	15,00	43,00	5,80 €	9,19 €
BV-D01897.0270U.00	BV-DB1897.0270B.00	2,70	2,70	17,00	46,00	5,80 €	9,19 €
BV-D01897.0275U.00	BV-DB1897.0275B.00	2,75	2,75	17,00	46,00	5,80 €	9,19 €
BV-D01897.0280U.00	BV-DB1897.0280B.00	2,80	2,80	17,00	46,00	5,80 €	9,19 €
BV-D01897.0285U.00	BV-DB1897.0285B.00	2,85	2,85	17,00	46,00	5,80 €	9,19 €
BV-D01897.0290U.00	BV-DB1897.0290B.00	2,90	2,90	17,00	46,00	5,80 €	9,19 €
BV-D01897.0295U.00	BV-DB1897.0295B.00	2,95	2,95	17,00	46,00	5,80 €	9,19 €
BV-D01897.0300U.00	BV-DB1897.0300B.00	3,00	3,00	17,00	46,00	5,80 €	9,19 €
BV-D01897.0305U.00	BV-DB1897.0305B.00	3,05	3,05	19,00	49,00	6,99 €	10,37 €
BV-D01897.0310U.00	BV-DB1897.0310B.00	3,10	3,10	19,00	49,00	6,99 €	10,37 €
BV-D01897.0315U.00	BV-DB1897.0315B.00	3,15	3,15	19,00	49,00	6,99 €	10,37 €
BV-D01897.0320U.00	BV-DB1897.0320B.00	3,20	3,20	19,00	49,00	6,99 €	10,37 €
BV-D01897.0325U.00	BV-DB1897.0325B.00	3,25	3,25	19,00	49,00	6,99 €	10,37 €
BV-D01897.0330U.00	BV-DB1897.0330B.00	3,30	3,30	19,00	49,00	6,99 €	10,37 €
BV-D01897.0335U.00	BV-DB1897.0335B.00	3,35	3,35	19,00	49,00	6,99 €	10,37 €
BV-D01897.0340U.00	BV-DB1897.0340B.00	3,40	3,40	21,00	52,00	6,99 €	10,48 €
BV-D01897.0345U.00	BV-DB1897.0345B.00	3,45	3,45	21,00	52,00	6,99 €	10,48 €
BV-D01897.0350U.00	BV-DB1897.0350B.00	3,50	3,50	21,00	52,00	6,99 €	10,48 €
BV-D01897.0355U.00	BV-DB1897.0355B.00	3,55	3,55	21,00	52,00	7,94 €	11,43 €
BV-D01897.0360U.00	BV-DB1897.0360B.00	3,60	3,60	21,00	52,00	7,94 €	11,43 €
BV-D01897.0365U.00	BV-DB1897.0365B.00	3,65	3,65	21,00	52,00	7,94 €	11,43 €
BV-D01897.0370U.00	BV-DB1897.0370B.00	3,70	3,70	21,00	52,00	7,94 €	11,43 €
BV-D01897.0375U.00	BV-DB1897.0375B.00	3,75	3,75	21,00	52,00	7,94 €	11,43 €
BV-D01897.0380U.00	BV-DB1897.0380B.00	3,80	3,80	23,00	55,00	7,94 €	11,43 €
BV-D01897.0385U.00	BV-DB1897.0385B.00	3,85	3,85	23,00	55,00	7,94 €	11,43 €
BV-D01897.0390U.00	BV-DB1897.0390B.00	3,90	3,90	23,00	55,00	7,94 €	11,43 €
BV-D01897.0395U.00	BV-DB1897.0395B.00	3,95	3,95	23,00	55,00	7,94 €	11,43 €
BV-D01897.0400U.00	BV-DB1897.0400B.00	4,00	4,00	23,00	55,00	7,94 €	11,43 €
BV-D01897.0405U.00	BV-DB1897.0405B.00	4,05	4,05	23,00	55,00	10,22 €	13,86 €
BV-D01897.0410U.00	BV-DB1897.0410B.00	4,10	4,10	23,00	55,00	10,22 €	13,86 €
BV-D01897.0415U.00	BV-DB1897.0415B.00	4,15	4,15	23,00	55,00	10,22 €	13,86 €
BV-D01897.0420U.00	BV-DB1897.0420B.00	4,20	4,20	23,00	55,00	10,22 €	13,86 €
BV-D01897.0425U.00	BV-DB1897.0425B.00	4,25	4,25	23,00	55,00	10,22 €	13,86 €
BV-D01897.0430U.00	BV-DB1897.0430B.00	4,30	4,30	25,00	58,00	10,22 €	13,86 €
BV-D01897.0435U.00	BV-DB1897.0435B.00	4,35	4,35	25,00	58,00	10,22 €	13,86 €
BV-D01897.0440U.00	BV-DB1897.0440B.00	4,40	4,40	25,00	58,00	10,22 €	13,86 €
BV-D01897.0445U.00	BV-DB1897.0445B.00	4,45	4,45	25,00	58,00	10,22 €	13,86 €



BV-D01897/BV-DB1897 UNBESCHICHTET UND BESCHICHTET

BV-D01897.0450U.00	BV-DB1897.0450B.00	4,50	4,50	25,00	58,00	10,22 €	13,86 €
BV-D01897.0455U.00	BV-DB1897.0455B.00	4,55	4,55	25,00	58,00	11,46 €	15,10 €
BV-D01897.0460U.00	BV-DB1897.0460B.00	4,60	4,60	25,00	58,00	11,46 €	15,10 €
BV-D01897.0465U.00	BV-DB1897.0465B.00	4,65	4,65	25,00	58,00	11,46 €	15,10 €
BV-D01897.0470U.00	BV-DB1897.0470B.00	4,70	4,70	25,00	58,00	11,46 €	15,10 €
BV-D01897.0475U.00	BV-DB1897.0475B.00	4,75	4,75	25,00	58,00	11,46 €	15,10 €
BV-D01897.0480U.00	BV-DB1897.0480B.00	4,80	4,80	27,00	62,00	11,46 €	15,10 €
BV-D01897.0485U.00	BV-DB1897.0485B.00	4,85	4,85	27,00	62,00	11,46 €	15,10 €
BV-D01897.0490U.00	BV-DB1897.0490B.00	4,90	4,90	27,00	62,00	11,46 €	15,10 €
BV-D01897.0495U.00	BV-DB1897.0495B.00	4,95	4,95	27,00	62,00	11,46 €	15,10 €
BV-D01897.0500U.00	BV-DB1897.0500B.00	5,00	5,00	27,00	62,00	11,46 €	15,10 €
BV-D01897.0505U.00	BV-DB1897.0505B.00	5,05	5,05	27,00	62,00	13,93 €	17,57 €
BV-D01897.0510U.00	BV-DB1897.0510B.00	5,10	5,10	27,00	62,00	13,93 €	17,57 €
BV-D01897.0515U.00	BV-DB1897.0515B.00	5,15	5,15	27,00	62,00	13,93 €	17,57 €
BV-D01897.0520U.00	BV-DB1897.0520B.00	5,20	5,20	27,00	62,00	13,93 €	17,57 €
BV-D01897.0525U.00	BV-DB1897.0525B.00	5,25	5,25	27,00	62,00	13,93 €	17,57 €
BV-D01897.0530U.00	BV-DB1897.0530B.00	5,30	5,30	27,00	62,00	13,93 €	17,57 €
BV-D01897.0535U.00	BV-DB1897.0535B.00	5,35	5,35	29,00	66,00	13,93 €	17,57 €
BV-D01897.0540U.00	BV-DB1897.0540B.00	5,40	5,40	29,00	66,00	13,93 €	17,57 €
BV-D01897.0545U.00	BV-DB1897.0545B.00	5,45	5,45	29,00	66,00	13,93 €	17,57 €
BV-D01897.0550U.00	BV-DB1897.0550B.00	5,50	5,50	29,00	66,00	13,93 €	17,57 €
BV-D01897.0555U.00	BV-DB1897.0555B.00	5,55	5,55	29,00	66,00	15,93 €	19,57 €
BV-D01897.0560U.00	BV-DB1897.0560B.00	5,60	5,60	29,00	66,00	15,93 €	19,57 €
BV-D01897.0565U.00	BV-DB1897.0565B.00	5,65	5,65	29,00	66,00	15,93 €	19,57 €
BV-D01897.0570U.00	BV-DB1897.0570B.00	5,70	5,70	29,00	66,00	15,93 €	19,57 €
BV-D01897.0575U.00	BV-DB1897.0575B.00	5,75	5,75	29,00	66,00	15,93 €	19,57 €
BV-D01897.0580U.00	BV-DB1897.0580B.00	5,80	5,80	29,00	66,00	15,93 €	19,57 €
BV-D01897.0585U.00	BV-DB1897.0585B.00	5,85	5,85	29,00	66,00	15,93 €	19,57 €
BV-D01897.0590U.00	BV-DB1897.0590B.00	5,90	5,90	29,00	66,00	15,93 €	19,57 €
BV-D01897.0595U.00	BV-DB1897.0595B.00	5,95	5,95	29,00	66,00	15,93 €	19,57 €
BV-D01897.0600U.00	BV-DB1897.0600B.00	6,00	6,00	29,00	66,00	15,93 €	19,57 €
BV-D01897.0605U.00	BV-DB1897.0605B.00	6,05	6,05	32,00	70,00	19,07 €	22,85 €
BV-D01897.0610U.00	BV-DB1897.0610B.00	6,10	6,10	32,00	70,00	19,07 €	22,85 €
BV-D01897.0615U.00	BV-DB1897.0615B.00	6,15	6,15	32,00	70,00	19,07 €	22,85 €
BV-D01897.0620U.00	BV-DB1897.0620B.00	6,20	6,20	32,00	70,00	19,07 €	22,85 €
BV-D01897.0625U.00	BV-DB1897.0625B.00	6,25	6,25	32,00	70,00	19,07 €	22,85 €
BV-D01897.0630U.00	BV-DB1897.0630B.00	6,30	6,30	32,00	70,00	19,07 €	22,85 €
BV-D01897.0635U.00	BV-DB1897.0635B.00	6,35	6,35	32,00	70,00	19,07 €	22,85 €
BV-D01897.0640U.00	BV-DB1897.0640B.00	6,40	6,40	32,00	70,00	19,07 €	22,85 €
BV-D01897.0645U.00	BV-DB1897.0645B.00	6,45	6,45	32,00	70,00	19,07 €	22,85 €
BV-D01897.0650U.00	BV-DB1897.0650B.00	6,50	6,50	32,00	70,00	19,07 €	22,85 €
BV-D01897.0655U.00	BV-DB1897.0655B.00	6,55	6,55	32,00	70,00	22,97 €	26,75 €
BV-D01897.0660U.00	BV-DB1897.0660B.00	6,60	6,60	32,00	70,00	22,97 €	26,75 €
BV-D01897.0665U.00	BV-DB1897.0665B.00	6,65	6,65	32,00	70,00	22,97 €	26,75 €



BV-D01897/BV-DB1897 UNBESCHICHTET UND BESCHICHTET

BV-D01897.0670U.00	BV-DB1897.0670B.00	6,70	6,70	32,00	70,00	22,97 €	26,75 €
BV-D01897.0675U.00	BV-DB1897.0675B.00	6,75	6,75	35,00	74,00	22,97 €	26,75 €
BV-D01897.0680U.00	BV-DB1897.0680B.00	6,80	6,80	35,00	74,00	22,97 €	26,75 €
BV-D01897.0685U.00	BV-DB1897.0685B.00	6,85	6,85	35,00	74,00	22,97 €	26,75 €
BV-D01897.0690U.00	BV-DB1897.0690B.00	6,90	6,90	35,00	74,00	22,97 €	26,75 €
BV-D01897.0695U.00	BV-DB1897.0695B.00	6,95	6,95	35,00	74,00	22,97 €	26,75 €
BV-D01897.0700U.00	BV-DB1897.0700B.00	7,00	7,00	35,00	74,00	22,97 €	26,75 €
BV-D01897.0705U.00	BV-DB1897.0705B.00	7,05	7,05	35,00	74,00	26,72 €	30,51 €
BV-D01897.0710U.00	BV-DB1897.0710B.00	7,10	7,10	35,00	74,00	26,72 €	30,51 €
BV-D01897.0715U.00	BV-DB1897.0715B.00	7,15	7,15	35,00	74,00	26,72 €	30,51 €
BV-D01897.0720U.00	BV-DB1897.0720B.00	7,20	7,20	35,00	74,00	26,72 €	30,51 €
BV-D01897.0725U.00	BV-DB1897.0725B.00	7,25	7,25	35,00	74,00	26,72 €	30,51 €
BV-D01897.0730U.00	BV-DB1897.0730B.00	7,30	7,30	35,00	74,00	26,72 €	30,51 €
BV-D01897.0735U.00	BV-DB1897.0735B.00	7,35	7,35	35,00	74,00	26,72 €	30,51 €
BV-D01897.0740U.00	BV-DB1897.0740B.00	7,40	7,40	35,00	74,00	26,72 €	30,51 €
BV-D01897.0745U.00	BV-DB1897.0745B.00	7,45	7,45	35,00	74,00	26,72 €	30,51 €
BV-D01897.0750U.00	BV-DB1897.0750B.00	7,50	7,50	35,00	74,00	26,72 €	30,51 €
BV-D01897.0755U.00	BV-DB1897.0755B.00	7,55	7,55	38,00	79,00	31,33 €	35,34 €
BV-D01897.0760U.00	BV-DB1897.0760B.00	7,60	7,60	38,00	79,00	31,33 €	35,34 €
BV-D01897.0765U.00	BV-DB1897.0765B.00	7,65	7,65	38,00	79,00	31,33 €	35,34 €
BV-D01897.0770U.00	BV-DB1897.0770B.00	7,70	7,70	38,00	79,00	31,33 €	35,34 €
BV-D01897.0775U.00	BV-DB1897.0775B.00	7,75	7,75	38,00	79,00	31,33 €	35,34 €
BV-D01897.0780U.00	BV-DB1897.0780B.00	7,80	7,80	38,00	79,00	31,33 €	35,34 €
BV-D01897.0785U.00	BV-DB1897.0785B.00	7,85	7,85	38,00	79,00	31,33 €	35,34 €
BV-D01897.0790U.00	BV-DB1897.0790B.00	7,90	7,90	38,00	79,00	31,33 €	35,34 €
BV-D01897.0795U.00	BV-DB1897.0795B.00	7,95	7,95	38,00	79,00	31,33 €	35,34 €
BV-D01897.0800U.00	BV-DB1897.0800B.00	8,00	8,00	38,00	79,00	31,33 €	35,34 €
BV-D01897.0805U.00	BV-DB1897.0805B.00	8,05	8,05	38,00	79,00	35,42 €	39,86 €
BV-D01897.0810U.00	BV-DB1897.0810B.00	8,10	8,10	38,00	79,00	35,42 €	39,86 €
BV-D01897.0815U.00	BV-DB1897.0815B.00	8,15	8,15	38,00	79,00	35,42 €	39,86 €
BV-D01897.0820U.00	BV-DB1897.0820B.00	8,20	8,20	38,00	79,00	35,42 €	39,86 €
BV-D01897.0825U.00	BV-DB1897.0825B.00	8,25	8,25	38,00	79,00	35,42 €	39,86 €
BV-D01897.0830U.00	BV-DB1897.0830B.00	8,30	8,30	38,00	79,00	35,42 €	39,86 €
BV-D01897.0835U.00	BV-DB1897.0835B.00	8,35	8,35	38,00	79,00	35,42 €	39,86 €
BV-D01897.0840U.00	BV-DB1897.0840B.00	8,40	8,40	38,00	79,00	35,42 €	39,86 €
BV-D01897.0845U.00	BV-DB1897.0845B.00	8,45	8,45	38,00	79,00	35,42 €	39,86 €
BV-D01897.0850U.00	BV-DB1897.0850B.00	8,50	8,50	38,00	79,00	35,42 €	39,86 €
BV-D01897.0855U.00	BV-DB1897.0855B.00	8,55	8,55	41,00	84,00	41,65 €	46,09 €
BV-D01897.0860U.00	BV-DB1897.0860B.00	8,60	8,60	41,00	84,00	41,65 €	46,09 €
BV-D01897.0865U.00	BV-DB1897.0865B.00	8,65	8,65	41,00	84,00	41,65 €	46,09 €
BV-D01897.0870U.00	BV-DB1897.0870B.00	8,70	8,70	41,00	84,00	41,65 €	46,09 €
BV-D01897.0875U.00	BV-DB1897.0875B.00	8,75	8,75	41,00	84,00	41,65 €	46,09 €
BV-D01897.0880U.00	BV-DB1897.0880B.00	8,80	8,80	41,00	84,00	41,65 €	46,09 €
BV-D01897.0885U.00	BV-DB1897.0885B.00	8,85	8,85	41,00	84,00	41,65 €	46,09 €

**BV-D01897/BV-DB1897
UNBESCHICHTET UND BESCHICHTET**

BV-D01897.0890U.00	BV-DB1897.0890B.00	8,90	8,90	41,00	84,00	41,65 €	46,09 €
BV-D01897.0895U.00	BV-DB1897.0895B.00	8,95	8,95	41,00	84,00	41,65 €	46,09 €
BV-D01897.0900U.00	BV-DB1897.0900B.00	9,00	9,00	41,00	84,00	41,65 €	46,09 €
BV-D01897.0905U.00	BV-DB1897.0905B.00	9,05	9,05	41,00	84,00	47,55 €	51,99 €
BV-D01897.0910U.00	BV-DB1897.0910B.00	9,10	9,10	41,00	84,00	47,55 €	51,99 €
BV-D01897.0915U.00	BV-DB1897.0915B.00	9,15	9,15	41,00	84,00	47,55 €	51,99 €
BV-D01897.0920U.00	BV-DB1897.0920B.00	9,20	9,20	41,00	84,00	47,55 €	51,99 €
BV-D01897.0925U.00	BV-DB1897.0925B.00	9,25	9,25	41,00	84,00	47,55 €	51,99 €
BV-D01897.0930U.00	BV-DB1897.0930B.00	9,30	9,30	41,00	84,00	47,55 €	51,99 €
BV-D01897.0935U.00	BV-DB1897.0935B.00	9,35	9,35	41,00	84,00	47,55 €	51,99 €
BV-D01897.0940U.00	BV-DB1897.0940B.00	9,40	9,40	41,00	84,00	47,55 €	51,99 €
BV-D01897.0945U.00	BV-DB1897.0945B.00	9,45	9,45	41,00	84,00	47,55 €	51,99 €
BV-D01897.0950U.00	BV-DB1897.0950B.00	9,50	9,50	41,00	84,00	47,55 €	51,99 €
BV-D01897.0955U.00	BV-DB1897.0955B.00	9,55	9,55	44,00	89,00	53,63 €	58,07 €
BV-D01897.0960U.00	BV-DB1897.0960B.00	9,60	9,60	44,00	89,00	53,63 €	58,07 €
BV-D01897.0965U.00	BV-DB1897.0965B.00	9,65	9,65	44,00	89,00	53,63 €	58,07 €
BV-D01897.0970U.00	BV-DB1897.0970B.00	9,70	9,70	44,00	89,00	53,63 €	58,07 €
BV-D01897.0975U.00	BV-DB1897.0975B.00	9,75	9,75	44,00	89,00	53,63 €	58,07 €
BV-D01897.0980U.00	BV-DB1897.0980B.00	9,80	9,80	44,00	89,00	53,63 €	58,07 €
BV-D01897.0985U.00	BV-DB1897.0985B.00	9,85	9,85	44,00	89,00	53,63 €	58,07 €
BV-D01897.0990U.00	BV-DB1897.0990B.00	9,90	9,90	44,00	89,00	53,63 €	58,07 €
BV-D01897.0995U.00	BV-DB1897.0995B.00	9,95	9,95	44,00	89,00	61,19 €	65,63 €
BV-D01897.1000U.00	BV-DB1897.1000B.00	10,00	10,00	44,00	89,00	61,19 €	65,63 €
BV-D01897.1005U.00	BV-DB1897.1005B.00	10,05	10,05	44,00	89,00	61,19 €	66,00 €
BV-D01897.1010U.00	BV-DB1897.1010B.00	10,10	10,10	44,00	89,00	61,19 €	66,00 €
BV-D01897.1015U.00	BV-DB1897.1015B.00	10,15	10,15	44,00	89,00	61,19 €	66,00 €
BV-D01897.1020U.00	BV-DB1897.1020B.00	10,20	10,20	44,00	89,00	61,19 €	66,00 €
BV-D01897.1025U.00	BV-DB1897.1025B.00	10,25	10,25	44,00	89,00	61,19 €	66,00 €
BV-D01897.1030U.00	BV-DB1897.1030B.00	10,30	10,30	44,00	89,00	61,19 €	66,00 €
BV-D01897.1035U.00	BV-DB1897.1035B.00	10,35	10,35	44,00	89,00	61,19 €	66,00 €
BV-D01897.1040U.00	BV-DB1897.1040B.00	10,40	10,40	44,00	89,00	61,19 €	66,00 €
BV-D01897.1045U.00	BV-DB1897.1045B.00	10,45	10,45	44,00	89,00	67,90 €	72,70 €
BV-D01897.1050U.00	BV-DB1897.1050B.00	10,50	10,50	44,00	89,00	67,90 €	72,70 €
BV-D01897.1055U.00	BV-DB1897.1055B.00	10,55	10,55	44,00	89,00	67,90 €	72,70 €
BV-D01897.1060U.00	BV-DB1897.1060B.00	10,60	10,60	44,00	89,00	67,90 €	72,70 €
BV-D01897.1065U.00	BV-DB1897.1065B.00	10,65	10,65	48,00	95,00	67,90 €	72,70 €
BV-D01897.1070U.00	BV-DB1897.1070B.00	10,70	10,70	48,00	95,00	67,90 €	72,70 €
BV-D01897.1075U.00	BV-DB1897.1075B.00	10,75	10,75	48,00	95,00	67,90 €	72,70 €
BV-D01897.1080U.00	BV-DB1897.1080B.00	10,80	10,80	48,00	95,00	67,90 €	72,70 €
BV-D01897.1085U.00	BV-DB1897.1085B.00	10,85	10,85	48,00	95,00	67,90 €	72,70 €
BV-D01897.1090U.00	BV-DB1897.1090B.00	10,90	10,90	48,00	95,00	67,90 €	72,70 €
BV-D01897.1095U.00	BV-DB1897.1095B.00	10,95	10,95	48,00	95,00	73,37 €	78,17 €
BV-D01897.1100U.00	BV-DB1897.1100B.00	11,00	11,00	48,00	95,00	73,37 €	78,17 €
BV-D01897.1105U.00	BV-DB1897.1105B.00	11,05	11,05	48,00	95,00	73,37 €	78,17 €



BV-D01897/BV-DB1897 UNBESCHICHTET UND BESCHICHTET

BV-D01897.1110U.00	BV-DB1897.1110B.00	11,10	11,10	48,00	95,00	73,37 €	78,17 €
BV-D01897.1115U.00	BV-DB1897.1115B.00	11,15	11,15	48,00	95,00	73,37 €	78,17 €
BV-D01897.1120U.00	BV-DB1897.1120B.00	11,20	11,20	48,00	95,00	73,37 €	78,17 €
BV-D01897.1125U.00	BV-DB1897.1125B.00	11,25	11,25	48,00	95,00	73,37 €	78,17 €
BV-D01897.1130U.00	BV-DB1897.1130B.00	11,30	11,30	48,00	95,00	73,37 €	78,17 €
BV-D01897.1135U.00	BV-DB1897.1135B.00	11,35	11,35	48,00	95,00	73,37 €	78,17 €
BV-D01897.1140U.00	BV-DB1897.1140B.00	11,40	11,40	48,00	95,00	73,37 €	78,17 €
BV-D01897.1145U.00	BV-DB1897.1145B.00	11,45	11,45	48,00	95,00	81,31 €	86,11 €
BV-D01897.1150U.00	BV-DB1897.1150B.00	11,50	11,50	48,00	95,00	81,31 €	86,11 €
BV-D01897.1155U.00	BV-DB1897.1155B.00	11,55	11,55	48,00	95,00	81,31 €	86,11 €
BV-D01897.1160U.00	BV-DB1897.1160B.00	11,60	11,60	48,00	95,00	81,31 €	86,11 €
BV-D01897.1165U.00	BV-DB1897.1165B.00	11,65	11,65	48,00	95,00	81,31 €	86,11 €
BV-D01897.1170U.00	BV-DB1897.1170B.00	11,70	11,70	48,00	95,00	81,31 €	86,11 €
BV-D01897.1175U.00	BV-DB1897.1175B.00	11,75	11,75	48,00	95,00	81,31 €	86,11 €
BV-D01897.1180U.00	BV-DB1897.1180B.00	11,80	11,80	48,00	95,00	81,31 €	86,11 €
BV-D01897.1185U.00	BV-DB1897.1185B.00	11,85	11,85	52,00	102,00	81,31 €	86,37 €
BV-D01897.1190U.00	BV-DB1897.1190B.00	11,90	11,90	52,00	102,00	81,31 €	86,37 €
BV-D01897.1195U.00	BV-DB1897.1195B.00	11,95	11,95	52,00	102,00	93,88 €	98,93 €
BV-D01897.1200U.00	BV-DB1897.1200B.00	12,00	12,00	52,00	102,00	93,88 €	98,93 €



BV-D01897/BV-DB1897 UNBESCHICHTET UND BESCHICHTET

MATERIALBESCHREIBUNG

		Vc m/mm	f mm/U		f mm/U		f mm/U		f mm/U		f mm/U		f mm/U	
			0,50-2,00	2,00-4,00	4,00-6,00	6,00-8,00	8,00-10,00	10,00-12,00						
P.1	<500N/mm	65	0,030	0,080	0,080	0,120	0,120	0,150	0,150	0,160	0,160	0,200	0,200	0,220
P.2	<650N/mm	65	0,030	0,080	0,080	0,120	0,120	0,150	0,150	0,160	0,160	0,200	0,200	0,220
P.3	<800N/mm	60	0,030	0,080	0,080	0,120	0,120	0,150	0,150	0,160	0,160	0,200	0,200	0,220
P.4	<1000N/mm	50	0,030	0,080	0,080	0,120	0,120	0,150	0,150	0,160	0,160	0,200	0,200	0,220
P.5	<1400N/mm	40	0,030	0,060	0,060	0,100	0,100	0,120	0,120	0,140	0,140	0,160	0,160	2,000
P.6	Einsatz-ST <1000N/mm	50	0,030	0,080	0,080	0,120	0,120	0,150	0,150	0,160	0,160	0,200	0,200	0,220
P.7	Nitrier-ST <1000N/mm	50	0,030	0,080	0,080	0,120	0,120	0,150	0,150	0,160	0,160	0,200	0,200	0,220
P.8	Vergütung-ST 850N/mm	60	0,030	0,060	0,060	0,100	0,100	0,120	0,120	0,140	0,140	0,160	0,160	2,000
P.9	Werkzeug-ST 1000N/mm	40	0,030	0,080	0,080	0,120	0,120	0,150	0,150	0,160	0,160	0,200	0,200	0,220
M.1	VA <750N/mm	30	0,030	0,060	0,060	0,100	0,100	0,120	0,120	0,140	0,140	0,160	0,160	2,000
M.2	VA >750N/mm	20	0,030	0,060	0,060	0,100	0,100	0,120	0,120	0,140	0,140	0,160	0,160	2,000
K.1	Gusseisen <200HB	75	0,030	0,080	0,080	0,120	0,120	0,150	0,150	0,160	0,160	0,200	0,200	0,220
K.2	Temperguss	75	0,030	0,080	0,080	0,120	0,120	0,150	0,150	0,160	0,160	0,200	0,200	0,220
K.3	Gusseisen mit Kugelgraphit	70	0,030	0,060	0,060	0,100	0,100	0,120	0,120	0,140	0,140	0,160	0,160	2,000
N.1	AL <5%	180	0,070	0,100	0,100	0,150	0,150	0,200	0,200	0,250	0,250	0,280	0,280	0,300
N.2	AL <10%	170	0,070	0,100	0,100	0,150	0,150	0,200	0,200	0,250	0,250	0,280	0,280	0,300
N.3	AL >10%	160	0,060	0,080	0,080	0,130	0,130	0,180	0,180	0,220	0,220	0,250	0,250	0,280
N.4	Ms, Cu, Bronze, Rotguss	160	0,070	0,100	0,100	0,150	0,150	0,200	0,200	0,250	0,250	0,280	0,280	0,300
N.5	Duro-Thermoplast													
N.6	Graphit, GFK													
S.1	Titan													
S.2	Nickel													
H.1	45-52 HRC													
H.2	52-60 HRC													
H.3	60-65 HRC													



BV-NC0901

VHM-NC-ANBOHRER 90°



Artikel-Nr. Article-No.	D1 m7	D2 h6	L2	L1	Preis/Euro Price/Euro
BV-NC0901.0100U.00	1.00	3.00	3.00	38.00	22,71 €
BV-NC0901.0200U.00	2.00	3.00	5.00	38.00	21,54 €
BV-NC0901.0300U.00	3.00	3.00	6.00	40.00	19,41 €
BV-NC0901.0400U.00	4.00	4.00	8.00	50.00	19,15 €
BV-NC0901.0500U.00	5.00	5.00	12.00	50.00	19,70 €
BV-NC0901.0600U.00	6.00	6.00	16.00	50.00	21,19 €
BV-NC0901.0800U.00	8.00	8.00	20.00	64.00	29,10 €
BV-NC0901.1000U.00	10.00	10.00	25.00	75.00	41,40 €
BV-NC0901.1200U.00	12.00	12.00	28.00	75.00	52,36 €
BV-NC0901.1600U.00	16.00	16.00	30.00	75.00	77,83 €
BV-NC0901.2000U.00	20.00	20.00	35.00	75.00	108,90 €



MATERIALBESCHREIBUNG

		Vc m/min von/bis		f mm/U		f mm/U		f mm/U		f mm/U		f mm/U	
				Ø 1,0-3,0 von/bis	Ø 3,0-6,0 von/bis	Ø 6,0-10,0 von/bis	Ø 10,0-16,0 von/bis	Ø 16,0-20,0 von/bis	Ø 10,0-16,0 von/bis	Ø 16,0-20,0 von/bis			
P.1	<500N/mm	70	80	0,050	0,060	0,060	0,110	0,110	0,140	0,140	0,160	0,160	0,160
P.2	<650N/mm	65	75	0,050	0,060	0,060	0,110	0,110	0,140	0,140	0,160	0,160	0,160
P.3	<800N/mm	55	65	0,050	0,060	0,060	0,110	0,110	0,140	0,140	0,160	0,160	0,160
P.4	<1000N/mm	40	50	0,040	0,050	0,050	0,090	0,090	0,120	0,120	0,140	0,140	0,140
P.5	<1400N/mm	25	35	0,030	0,040	0,040	0,090	0,090	0,110	0,110	0,130	0,130	0,130
P.6	Einsatz-ST <1000N/mm	30	40	0,040	0,050	0,050	0,090	0,090	0,120	0,120	0,140	0,140	0,140
P.7	Nitrier-ST <1000N/mm	30	40	0,040	0,050	0,050	0,090	0,090	0,120	0,120	0,140	0,140	0,140
P.8	Vergütung-ST 850N/mm	40	50	0,040	0,050	0,050	0,090	0,090	0,120	0,120	0,140	0,140	0,140
P.9	Werkzeug-ST 1000N/mm	25	35	0,030	0,040	0,040	0,090	0,090	0,110	0,110	0,130	0,130	0,130
M.1	VA <750N/mm	20	30	0,010	0,010	0,010	0,030	0,030	0,070	0,070	0,070	0,070	0,070
M.2	VA >750N/mm	20	25	0,010	0,010	0,010	0,030	0,030	0,070	0,070	0,070	0,070	0,070
K.1	Gusseisen <200HB	60	70	0,030	0,040	0,040	0,090	0,090	0,110	0,110	0,130	0,130	0,130
K.2	Temperguss	60	70	0,030	0,040	0,040	0,090	0,090	0,110	0,110	0,130	0,130	0,130
K.3	Gusseisen mit Kugelgraphit	60	70	0,030	0,040	0,040	0,090	0,090	0,110	0,110	0,130	0,130	0,130
N.1	AL <5%	180	200	0,020	0,020	0,020	0,030	0,030	0,070	0,070	0,070	0,070	0,070
N.2	AL <10%	160	180	0,020	0,020	0,020	0,030	0,030	0,070	0,070	0,070	0,070	0,070
N.3	AL >10%	140	160	0,020	0,020	0,020	0,030	0,030	0,070	0,070	0,070	0,070	0,070
N.4	Ms, Cu, Bronze, Rotguss	60	80	0,010	0,010	0,010	0,020	0,020	0,060	0,060	0,070	0,070	0,070
N.5	Duro-Thermoplast	40	50	0,010	0,010	0,010	0,020	0,020	0,040	0,040	0,060	0,060	0,060
N.6	Grafit, GFK												
S.1	Titan												
S.2	Nickel												
H.1	45-52 HRC												
H.2	52-60 HRC												
H.3	60-65 HRC												



BV-NC1201 VHM-NC-ANBOHRER 120°

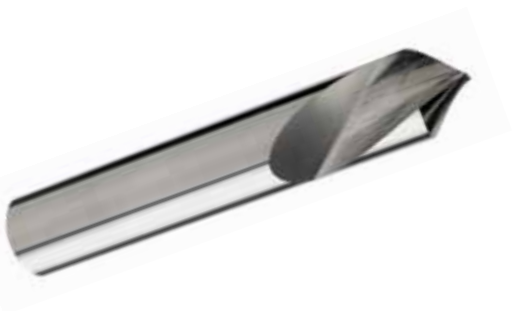

Artikel-Nr. Article-No.	D1 m7	D2 h6	L2	L1	Preis/Euro Price/Euro
BV-NC1201.0200U.00	2	2	8	40	17,58 €
BV-NC1201.0300U.00	3	3	10	50	19,60 €
BV-NC1201.0400U.00	4	4	12	50	21,81 €
BV-NC1201.0500U.00	5	5	15	50	23,66 €
BV-NC1201.0600U.00	6	6	18	50	26,88 €
BV-NC1201.0800U.00	8	8	23	60	37,18 €
BV-NC1201.1000U.00	10	10	24	70	51,90 €
BV-NC1201.1200U.00	12	12	24	70	69,97 €
BV-NC1201.1600U.00	16	16	26	80	111,05 €





BV-NC1201 VHM-NC-ANBOHRER 120°

MATERIALBESCHREIBUNG

		Vc m/min von/bis		f mm/U		f mm/U		f mm/U		f mm/U		f mm/U	
				Ø 1,0-3,0 von/bis		Ø 3,0-6,0 von/bis		Ø 6,0-10,0 von/bis		Ø 10,0-16,0 von/bis		Ø 16,0-20,0 von/bis	
P.1	<500N/mm	70	80	0,050	0,060	0,060	0,110	0,110	0,140	0,140	0,160	0,160	0,160
P.2	<650N/mm	65	75	0,050	0,060	0,060	0,110	0,110	0,140	0,140	0,160	0,160	0,160
P.3	<800N/mm	55	65	0,050	0,060	0,060	0,110	0,110	0,140	0,140	0,160	0,160	0,160
P.4	<1000N/mm	40	50	0,040	0,050	0,050	0,090	0,090	0,120	0,120	0,140	0,140	0,140
P.5	<1400N/mm	25	35	0,030	0,040	0,040	0,090	0,090	0,110	0,110	0,130	0,130	0,130
P.6	Einsatz-ST <1000N/mm	30	40	0,040	0,050	0,050	0,090	0,090	0,120	0,120	0,140	0,140	0,140
P.7	Nitrier-ST <1000N/mm	30	40	0,040	0,050	0,050	0,090	0,090	0,120	0,120	0,140	0,140	0,140
P.8	Vergütung-ST 850N/mm	40	50	0,040	0,050	0,050	0,090	0,090	0,120	0,120	0,140	0,140	0,140
P.9	Werkzeug-ST 1000N/mm	25	35	0,030	0,040	0,040	0,090	0,090	0,110	0,110	0,130	0,130	0,130
M.1	VA <750N/mm	20	30	0,010	0,010	0,010	0,030	0,030	0,070	0,070	0,070	0,070	0,070
M.2	VA >750N/mm	20	25	0,010	0,010	0,010	0,030	0,030	0,070	0,070	0,070	0,070	0,070
K.1	Gusseisen <200HB	60	70	0,030	0,040	0,040	0,090	0,090	0,110	0,110	0,130	0,130	0,130
K.2	Temperguss	60	70	0,030	0,040	0,040	0,090	0,090	0,110	0,110	0,130	0,130	0,130
K.3	Gusseisen mit Kugelgrafit	60	70	0,030	0,040	0,040	0,090	0,090	0,110	0,110	0,130	0,130	0,130
N.1	AL <5%	180	200	0,020	0,020	0,020	0,030	0,030	0,070	0,070	0,070	0,070	0,070
N.2	AL <10%	160	180	0,020	0,020	0,020	0,030	0,030	0,070	0,070	0,070	0,070	0,070
N.3	AL >10%	140	160	0,020	0,020	0,020	0,030	0,030	0,070	0,070	0,070	0,070	0,070
N.4	Ms, Cu, Bronze, Rotguss	60	80	0,010	0,010	0,010	0,020	0,020	0,060	0,060	0,070	0,070	0,070
N.5	Duro-Thermoplast	40	50	0,010	0,010	0,010	0,020	0,020	0,040	0,040	0,060	0,060	0,060
N.6	Grafit, GFK												
S.1	Titan												
S.2	Nickel												
H.1	45-52 HRC												
H.2	52-60 HRC												
H.3	60-65 HRC												



BV-NC1421 VHM-NC-ANBOHRER 142°



Artikel-Nr. Article-No.	D1 m7	D2 h6	L2	L1	Preis/Euro Price/Euro
BV-NC1421.0300U.00	3	3	10	50	19,60 €
BV-NC1421.0400U.00	4	4	12	50	21,81 €
BV-NC1421.0500U.00	5	5	15	50	23,66 €
BV-NC1421.0600U.00	6	6	18	50	29,07 €
BV-NC1421.0800U.00	8	8	23	60	40,07 €
BV-NC1421.1000U.00	10	10	24	70	54,94 €
BV-NC1421.1200U.00	12	12	24	70	73,35 €
BV-NC1421.1600U.00	16	16	26	80	117,29 €





BV-NC1421 VHM-NC-ANBOHRER 142°

MATERIALBESCHREIBUNG

		Vc m/min von/bis		f mm/U		f mm/U		f mm/U		f mm/U		f mm/U	
				Ø 1,0-3,0 von/bis		Ø 3,0-6,0 von/bis		Ø 6,0-10,0 von/bis		Ø 10,0-16,0 von/bis		Ø 16,0-20,0 von/bis	
P.1	<500N/mm	70	80	0,050	0,060	0,060	0,110	0,110	0,140	0,140	0,160	0,160	0,160
P.2	<650N/mm	65	75	0,050	0,060	0,060	0,110	0,110	0,140	0,140	0,160	0,160	0,160
P.3	<800N/mm	55	65	0,050	0,060	0,060	0,110	0,110	0,140	0,140	0,160	0,160	0,160
P.4	<1000N/mm	40	50	0,040	0,050	0,050	0,090	0,090	0,120	0,120	0,140	0,140	0,140
P.5	<1400N/mm	25	35	0,030	0,040	0,040	0,090	0,090	0,110	0,110	0,130	0,130	0,130
P.6	Einsatz-ST <1000N/mm	30	40	0,040	0,050	0,050	0,090	0,090	0,120	0,120	0,140	0,140	0,140
P.7	Nitrier-ST <1000N/mm	30	40	0,040	0,050	0,050	0,090	0,090	0,120	0,120	0,140	0,140	0,140
P.8	Vergütung-ST 850N/mm	40	50	0,040	0,050	0,050	0,090	0,090	0,120	0,120	0,140	0,140	0,140
P.9	Werkzeug-ST 1000N/mm	25	35	0,030	0,040	0,040	0,090	0,090	0,110	0,110	0,130	0,130	0,130
M.1	VA <750N/mm	20	30	0,010	0,010	0,010	0,030	0,030	0,070	0,070	0,070	0,070	0,070
M.2	VA >750N/mm	20	25	0,010	0,010	0,010	0,030	0,030	0,070	0,070	0,070	0,070	0,070
K.1	Gusseisen <200HB	60	70	0,030	0,040	0,040	0,090	0,090	0,110	0,110	0,130	0,130	0,130
K.2	Temperguss	60	70	0,030	0,040	0,040	0,090	0,090	0,110	0,110	0,130	0,130	0,130
K.3	Gusseisen mit Kugelgrafit	60	70	0,030	0,040	0,040	0,090	0,090	0,110	0,110	0,130	0,130	0,130
N.1	AL <5%	180	200	0,020	0,020	0,020	0,030	0,030	0,070	0,070	0,070	0,070	0,070
N.2	AL <10%	160	180	0,020	0,020	0,020	0,030	0,030	0,070	0,070	0,070	0,070	0,070
N.3	AL >10%	140	160	0,020	0,020	0,020	0,030	0,030	0,070	0,070	0,070	0,070	0,070
N.4	Ms, Cu, Bronze, Rotguss	60	80	0,010	0,010	0,010	0,020	0,020	0,060	0,060	0,070	0,070	0,070
N.5	Duro-Thermoplast	40	50	0,010	0,010	0,010	0,020	0,020	0,040	0,040	0,060	0,060	0,060
N.6	Grafit, GFK												
S.1	Titan												
S.2	Nickel												
H.1	45-52 HRC												
H.2	52-60 HRC												
H.3	60-65 HRC												



BH-NC0911

HSSE-NC-ANBOHRER 90°

HSS-E



HA

TIN



Artikel-Nr. Article-No.	D1 m7	D2 h6	L2	L1	Preis/Euro Price/Euro
BH-NC0911.0200B.00	2	2	8	40	7,00 €
BH-NC0911.0300B.00	3	3	12	46	7,45 €
BH-NC0911.0400B.00	4	4	12	55	7,92 €
BH-NC0911.0500B.00	5	5	14	62	8,46 €
BH-NC0911.0600B.00	6	6	16	66	9,49 €
BH-NC0911.0800B.00	8	8	21	79	11,65 €
BH-NC0911.1000B.00	10	10	25	89	14,87 €
BH-NC0911.1200B.00	12	12	30	102	18,98 €
BH-NC0911.1400B.00	14	14	34	107	23,71 €
BH-NC0911.1600B.00	16	16	38	115	34,37 €
BH-NC0911.2000B.00	20	20	45	131	68,38 €
BH-NC0911.2500B.00	25	25	53	151	143,00 €



BH-NC0911

HSSE-NC-ANBOHRER 90°

MATERIALBESCHREIBUNG

		Vc m/mm	f mm/U		f mm/U		f mm/U		f mm/U		f mm/U	
			2,0-4,0	5,0-6,0	8,0-10,0	12,0-16,0	20					
P.1	<500N/mm	40-60	0,040	0,060	0,060	0,070	0,070	0,090	0,010	0,012	0,012	0,016
P.2	<650N/mm	35-50	0,040	0,060	0,060	0,070	0,070	0,090	0,010	0,012	0,012	0,016
P.3	<800N/mm	35-50	0,040	0,060	0,060	0,070	0,070	0,090	0,010	0,012	0,012	0,016
P.4	<1000N/mm	20-30	0,020	0,030	0,030	0,060	0,070	0,010	0,010	0,011	0,012	0,014
P.5	<1400N/mm	10-20	0,020	0,030	0,030	0,040	0,040	0,060	0,060	0,080	0,010	0,012
P.6	Einsatz-ST <1000N/mm	10-20	0,020	0,030	0,030	0,060	0,070	0,010	0,010	0,011	0,012	0,014
P.7	Nitrier-ST <1000N/mm	10-20	0,020	0,030	0,030	0,060	0,070	0,010	0,010	0,011	0,012	0,014
P.8	Vergütung-ST 850N/mm	15-20	0,040	0,060	0,060	0,070	0,070	0,090	0,010	0,012	0,012	0,016
P.9	Werkzeug-ST 1000N/mm	10-20	0,020	0,030	0,030	0,060	0,070	0,010	0,010	0,011	0,012	0,014
M.1	VA <750N/mm	10-20	0,020	0,030	0,030	0,060	0,070	0,010	0,010	0,011	0,012	0,014
M.2	VA >750N/mm	10-15	0,020	0,030	0,030	0,040	0,040	0,060	0,060	0,080	0,010	0,012
K.1	Gusseisen <200HB	25-35	0,040	0,060	0,060	0,070	0,070	0,090	0,010	0,012	0,012	0,016
K.2	Temperguss	25-35	0,040	0,060	0,060	0,070	0,070	0,090	0,010	0,012	0,012	0,016
K.3	Gusseisen mit Kugelgraphit	25-35	0,020	0,030	0,030	0,060	0,070	0,010	0,010	0,011	0,012	0,014
N.1	AL <5%	80-100	0,100	0,150	0,150	0,180	0,200	0,250	0,260	0,300	0,350	0,450
N.2	AL <10%	50-60	0,100	0,150	0,150	0,180	0,200	0,250	0,260	0,300	0,380	0,450
N.3	AL >10%	40-50	0,080	0,100	0,130	0,160	0,180	0,220	0,250	0,280	0,350	0,400
N.4	Ms, Cu, Bronze, Rotguss	50-60	0,080	0,100	0,090	0,110	0,120	0,160	0,160	0,180	0,250	0,280
N.5	Duro-Thermoplast	50-80	0,060	0,100	0,080	0,100	0,125	0,160	0,160	0,200	0,250	0,315
N.6	Grafit, GFK											
S.1	Titan											
S.2	Nickel											
H.1	45-52 HRC											
H.2	52-60 HRC											
H.3	60-65 HRC											



BH-NC1212

HSSE-NC-ANBOHRER 120°

HSS-E

120°

HA

TIN



Artikel-Nr. Article-No.	D1 m7	D2 h6	L2	L1	Preis/Euro Price/Euro
BH-NC1212.0200B.00	2	2	8	40	7,00 €
BH-NC1212.0300B.00	3	3	12	46	7,45 €
BH-NC1212.0400B.00	4	4	12	55	7,92 €
BH-NC1212.0500B.00	5	5	14	62	8,46 €
BH-NC1212.0600B.00	6	6	16	66	9,49 €
BH-NC1212.0800B.00	8	8	21	79	11,65 €
BH-NC1212.1000B.00	10	10	25	89	14,87 €
BH-NC1212.1200B.00	12	12	30	102	18,98 €
BH-NC1212.1400B.00	14	14	34	107	23,71 €
BH-NC1212.1600B.00	16	16	38	115	34,37 €
BH-NC1212.2000B.00	20	20	45	131	68,38 €
BH-NC1212.2500B.00	25	25	53	151	143,00 €



BH-NC1212 HSSE-NC-ANBOHRER 120°

MATERIALBESCHREIBUNG

			f mm/U		f mm/U		f mm/U		f mm/U		f mm/U	
		Vc m/mm	2,0-4,0		5,0-6,0		8,0-10,0		12,0-16,0		20	
P.1	<500N/mm	40-60	0,040	0,060	0,060	0,070	0,070	0,090	0,010	0,012	0,012	0,016
P.2	<650N/mm	35-50	0,040	0,060	0,060	0,070	0,070	0,090	0,010	0,012	0,012	0,016
P.3	<800N/mm	35-50	0,040	0,060	0,060	0,070	0,070	0,090	0,010	0,012	0,012	0,016
P.4	<1000N/mm	20-30	0,020	0,030	0,030	0,060	0,070	0,010	0,010	0,011	0,012	0,014
P.5	<1400N/mm	10-20	0,020	0,030	0,030	0,040	0,040	0,060	0,060	0,080	0,010	0,012
P.6	Einsatz-ST <1000N/mm	10-20	0,020	0,030	0,030	0,060	0,070	0,010	0,010	0,011	0,012	0,014
P.7	Nitrier-ST <1000N/mm	10-20	0,020	0,030	0,030	0,060	0,070	0,010	0,010	0,011	0,012	0,014
P.8	Vergütung-ST 850N/mm	15-20	0,040	0,060	0,060	0,070	0,070	0,090	0,010	0,012	0,012	0,016
P.9	Werkzeug-ST 1000N/mm	10-20	0,020	0,030	0,030	0,060	0,070	0,010	0,010	0,011	0,012	0,014
M.1	VA <750N/mm	10-20	0,020	0,030	0,030	0,060	0,070	0,010	0,010	0,011	0,012	0,014
M.2	VA >750N/mm	10-15	0,020	0,030	0,030	0,040	0,040	0,060	0,060	0,080	0,010	0,012
K.1	Gusseisen <200HB	25-35	0,040	0,060	0,060	0,070	0,070	0,090	0,010	0,012	0,012	0,016
K.2	Temperguss	25-35	0,040	0,060	0,060	0,070	0,070	0,090	0,010	0,012	0,012	0,016
K.3	Gusseisen mit Kugelgraphit	25-35	0,020	0,030	0,030	0,060	0,070	0,010	0,010	0,011	0,012	0,014
N.1	AL <5%	80-100	0,100	0,150	0,150	0,180	0,200	0,250	0,260	0,300	0,350	0,450
N.2	AL <10%	50-60	0,100	0,150	0,150	0,180	0,200	0,250	0,260	0,300	0,380	0,450
N.3	AL >10%	40-50	0,080	0,100	0,130	0,160	0,180	0,220	0,250	0,280	0,350	0,400
N.4	Ms, Cu, Bronze, Rotguss	50-60	0,080	0,100	0,090	0,110	0,120	0,160	0,160	0,180	0,250	0,280
N.5	Duro-Thermoplast	50-80	0,060	0,100	0,080	0,100	0,125	0,160	0,160	0,200	0,250	0,315
N.6	Grafit, GFK											
S.1	Titan											
S.2	Nickel											
H.1	45-52 HRC											
H.2	52-60 HRC											
H.3	60-65 HRC											



BH-ZA001

HSS-ZENTRIERBOHRER FORM A

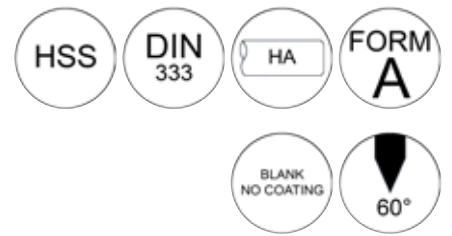

Artikel-Nr. Article-No.	D1	D2	L2 von	L2 bis	L1	Preis/Euro Price/Euro
BH-ZA001.0050U.315	0,50	3,15	0,6	0,9	25	5,41 €
BH-ZA001.0063U.315	0,63	3,15	0,7	1,0	25	5,59 €
BH-ZA001.0080U.315	0,80	3,15	1,0	1,3	25	5,41 €
BH-ZA001.0100U.315	1,00	3,15	1,3	1,7	31	5,25 €
BH-ZA001.0100U.400	1,00	4,00	1,3	1,7	35	8,79 €
BH-ZA001.0125U.400	1,25	4,00	1,6	2,0	35	5,93 €
BH-ZA001.0125U.315	1,25	3,15	1,6	2,0	31	5,25 €
BH-ZA001.0160U.400	1,60	4,00	2,0	2,6	40	5,25 €
BH-ZA001.0160U.500	1,60	5,00	2,0	2,6	35	6,27 €
BH-ZA001.0200U.500	2,00	5,00	2,5	3,1	40	5,75 €
BH-ZA001.0200U.600	2,00	6,00	2,5	3,1	45	10,32 €
BH-ZA001.0200U.630	2,00	6,30	2,5	3,1	45	7,10 €
BH-ZA001.0250U.630	2,50	6,30	3,1	3,8	45	6,27 €
BH-ZA001.0250U.800	2,50	8,00	3,1	3,8	50	8,79 €
BH-ZA001.0315U.100	3,15	10,00	3,9	4,6	55	11,00 €
BH-ZA001.0315U.800	3,15	8,00	3,9	4,6	50	8,11 €
BH-ZA001.0400U.100	4,00	10,00	5,0	5,9	55	10,14 €
BH-ZA001.0400U.125	4,00	12,50	5,0	5,9	63	17,42 €
BH-ZA001.0500U.125	5,00	12,50	6,3	7,2	63	16,56 €
BH-ZA001.0630U.160	6,30	16,00	8,0	8,9	71	29,74 €
BH-ZA001.0630U.200	6,30	20,00	8,0	8,9	80	48,85 €
BH-ZA001.0800U.200	8,00	20,00	10,1	11,1	80	45,14 €
BH-ZA001.0800U.250	8,00	25,00	10,1	11,1	100	88,56 €
BH-ZA001.1000U.250	10,00	25,00	12,8	13,8	100	83,33 €



BH-ZA001 HSS-ZENTRIERBOHRER FORM A

MATERIALBESCHREIBUNG

		Vc m/min von/bis		f mm/U		f mm/U		f mm/U		f mm/U		f mm/U	
				Ø 1,0-3,0 von/bis		Ø 3,0-6,0 von/bis		Ø 6,0-10,0 von/bis		Ø 10,0-16,0 von/bis		Ø 16,0-20,0 von/bis	
P.1	<500N/mm	30	45	0,020	0,030	0,030	0,050	0,050	0,080	0,080	0,110	0,110	0,150
P.2	<650N/mm	30	40	0,020	0,030	0,030	0,050	0,050	0,080	0,080	0,110	0,110	0,150
P.3	<800N/mm	25	35	0,020	0,030	0,030	0,050	0,050	0,080	0,080	0,110	0,110	0,150
P.4	<1000N/mm	10	20	0,010	0,020	0,020	0,030	0,030	0,040	0,050	0,070	0,070	0,100
P.5	<1400N/mm	5	10	0,010	0,020	0,020	0,030	0,030	0,040	0,050	0,070	0,070	0,100
P.6	Einsatz-ST <1000N/mm	15	25	0,010	0,020	0,020	0,030	0,030	0,040	0,050	0,070	0,070	0,100
P.7	Nitrier-ST <1000N/mm	10	15	0,010	0,020	0,020	0,030	0,030	0,040	0,050	0,070	0,070	0,100
P.8	Vergütung-ST 850N/mm	15	20	0,010	0,020	0,020	0,030	0,030	0,040	0,050	0,070	0,070	0,100
P.9	Werkzeug-ST 1000N/mm	7	12	0,010	0,020	0,020	0,030	0,030	0,040	0,050	0,070	0,070	0,100
M.1	VA <750N/mm	10	15	0,010	0,010	0,020	0,020	0,020	0,050	0,050	0,060	0,060	0,090
M.2	VA >750N/mm	10	15	0,010	0,010	0,020	0,020	0,020	0,050	0,050	0,060	0,060	0,090
K.1	Gusseisen <200HB	20	30	0,020	0,030	0,030	0,050	0,050	0,080	0,080	0,110	0,110	0,150
K.2	Temperguss	20	30	0,020	0,030	0,030	0,040	0,040	0,060	0,060	0,090	0,090	0,130
K.3	Gusseisen mit Kugelgrafit												
N.1	AL <5%	60	80	0,020	0,030	0,030	0,050	0,050	0,080	0,080	0,110	0,110	0,150
N.2	AL <10%	40	60	0,020	0,030	0,030	0,050	0,050	0,080	0,080	0,110	0,110	0,150
N.3	AL >10%	40	80	0,020	0,030	0,030	0,050	0,050	0,080	0,080	0,110	0,110	0,150
N.4	Ms, Cu, Bronze, Rotguss	15	40	0,020	0,030	0,040	0,050	0,050	0,090	0,090	0,100	0,100	0,130
N.5	Duro-Thermoplast												
N.6	Grafit, GFK												
S.1	Titan												
S.2	Nickel												
H.1	45-52 HRC												
H.2	52-60 HRC												
H.3	60-65 HRC												



BH-ZR002

HSS-ZENTRIERBOHRER FORM R

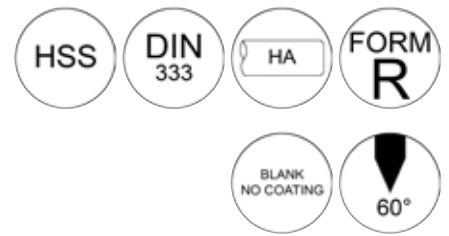

Artikel-Nr. Article-No.	D1	D2	L2 von	L2 bis	L1	Preis/Euro Price/Euro
BH-ZR002.0050U.315	0,50	3,15	2,30	2,60	25,00	5,59 €
BH-ZR002.0080U.315	0,80	3,15	2,60	2,90	25,00	5,59 €
BH-ZR002.0100U.315	1,00	3,15	3,00	3,30	31,00	5,41 €
BH-ZR002.0100U.400	1,00	4,00	3,30	3,60	35,00	8,97 €
BH-ZR002.0125U.400	1,25	4,00	3,70	4,10	35,00	6,08 €
BH-ZR002.0125U.315	1,25	3,15	3,30	3,60	31,00	5,41 €
BH-ZR002.0160U.400	1,60	4,00	4,20	4,70	35,00	5,41 €
BH-ZR002.0200U.500	2,00	5,00	5,00	5,40	40,00	5,93 €
BH-ZR002.0200U.630	2,00	6,30	5,60	6,00	45,00	7,28 €
BH-ZR002.0250U.630	2,50	6,30	6,30	6,80	45,00	6,76 €
BH-ZR002.0250U.800	2,50	8,00	7,50	8,00	50,00	8,97 €
BH-ZR002.0200U.600	2,00	6,00	5,40	5,80	45,00	10,66 €
BH-ZR002.0300U.800	3,00	8,00	8,00	8,50	50,00	11,67 €
BH-ZR002.0315U.800	3,15	8,00	8,00	8,50	50,00	7,96 €
BH-ZR002.0400U.100	4,00	10,00	10,00	10,60	55,00	10,32 €
BH-ZR002.0500U.125	5,00	12,50	12,50	13,10	63,00	16,41 €
BH-ZR002.0630U.160	6,30	16,00	16,00	16,60	71,00	29,41 €
BH-ZR002.0630U.200	6,30	20,00	17,80	19,00	80,00	50,02 €
BH-ZR002.0800U.200	8,00	20,00	20,00	20,70	80,00	46,31 €
BH-ZR002.1000U.250	10,00	25,00	25,00	25,70	100,00	85,36 €
BH-ZR002.1250U.315	12,50	31,50	31,50	32,30	125,00	231,71 €



BH-ZR002 HSS-ZENTRIERBOHRER FORM R

MATERIALBESCHREIBUNG

		Vc m/min von/bis		f mm/U		f mm/U		f mm/U		f mm/U		f mm/U	
				Ø 1,0-3,0 von/bis		Ø 3,0-6,0 von/bis		Ø 6,0-10,0 von/bis		Ø 10,0-16,0 von/bis		Ø 16,0-20,0 von/bis	
P.1	<500N/mm	30	45	0,020	0,030	0,030	0,050	0,050	0,080	0,080	0,110	0,110	0,150
P.2	<650N/mm	30	40	0,020	0,030	0,030	0,050	0,050	0,080	0,080	0,110	0,110	0,150
P.3	<800N/mm	25	35	0,020	0,030	0,030	0,050	0,050	0,080	0,080	0,110	0,110	0,150
P.4	<1000N/mm	10	20	0,010	0,020	0,020	0,030	0,030	0,040	0,050	0,070	0,070	0,100
P.5	<1400N/mm	5	10	0,010	0,020	0,020	0,030	0,030	0,040	0,050	0,070	0,070	0,100
P.6	Einsatz-ST <1000N/mm	15	25	0,010	0,020	0,020	0,030	0,030	0,040	0,050	0,070	0,070	0,100
P.7	Nitrier-ST <1000N/mm	10	15	0,010	0,020	0,020	0,030	0,030	0,040	0,050	0,070	0,070	0,100
P.8	Vergütung-ST 850N/mm	15	20	0,010	0,020	0,020	0,030	0,030	0,040	0,050	0,070	0,070	0,100
P.9	Werkzeug-ST 1000N/mm	7	12	0,010	0,020	0,020	0,030	0,030	0,040	0,050	0,070	0,070	0,100
M.1	VA <750N/mm	10	15	0,010	0,010	0,020	0,020	0,020	0,050	0,050	0,060	0,060	0,090
M.2	VA >750N/mm	10	15	0,010	0,010	0,020	0,020	0,020	0,050	0,050	0,060	0,060	0,090
K.1	Gusseisen <200HB	20	30	0,020	0,030	0,030	0,050	0,050	0,080	0,080	0,110	0,110	0,150
K.2	Temperguss	20	30	0,020	0,030	0,030	0,040	0,040	0,060	0,060	0,090	0,090	0,130
K.3	Gusseisen mit Kugelgrafit												
N.1	AL <5%	60	80	0,020	0,030	0,030	0,050	0,050	0,080	0,080	0,110	0,110	0,150
N.2	AL <10%	40	60	0,020	0,030	0,030	0,050	0,050	0,080	0,080	0,110	0,110	0,150
N.3	AL >10%	40	80	0,020	0,030	0,030	0,050	0,050	0,080	0,080	0,110	0,110	0,150
N.4	Ms, Cu, Bronze, Rotguss	15	40	0,020	0,030	0,040	0,050	0,050	0,090	0,090	0,100	0,100	0,130
N.5	Duro-Thermoplast												
N.6	Grafit, GFK												
S.1	Titan												
S.2	Nickel												
H.1	45-52 HRC												
H.2	52-60 HRC												
H.3	60-65 HRC												

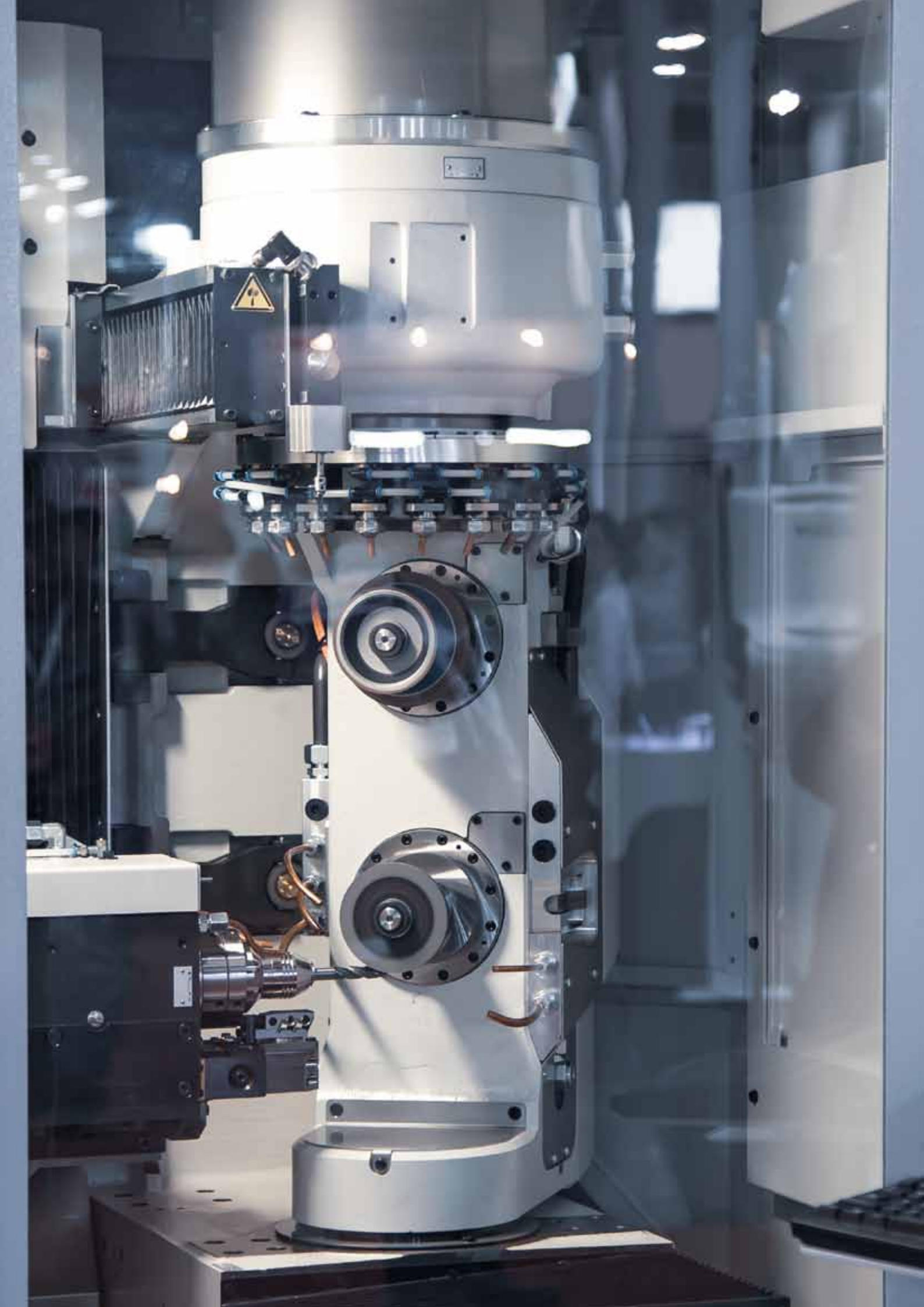

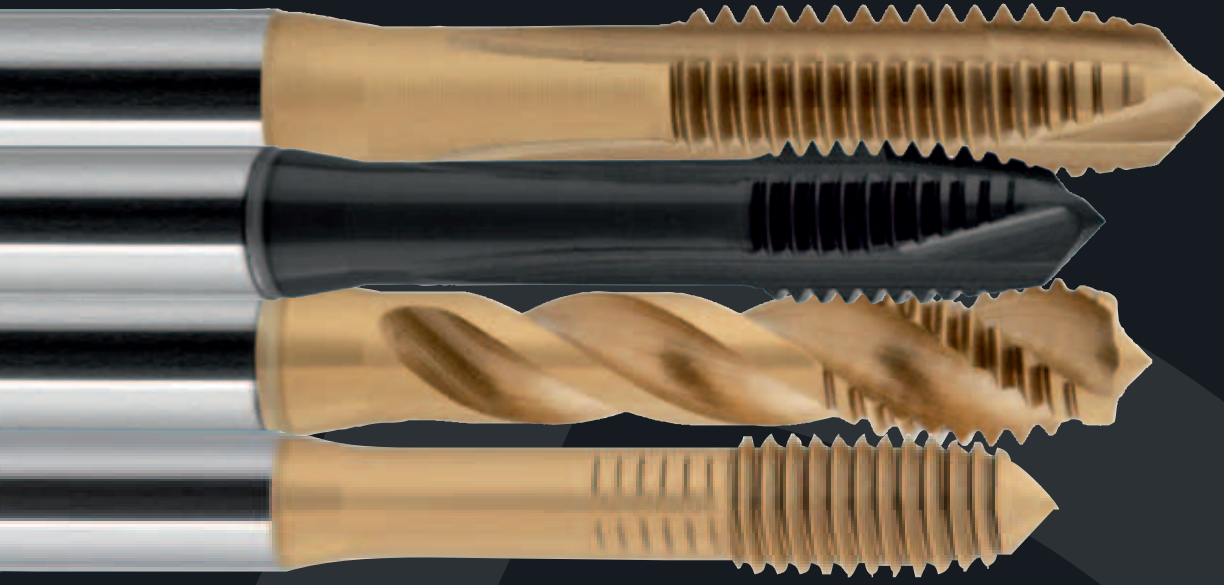

HALLAS
TOOLS

GEWINDEWERKZEUGE



BESCHREIBUNG WERKZEUGE

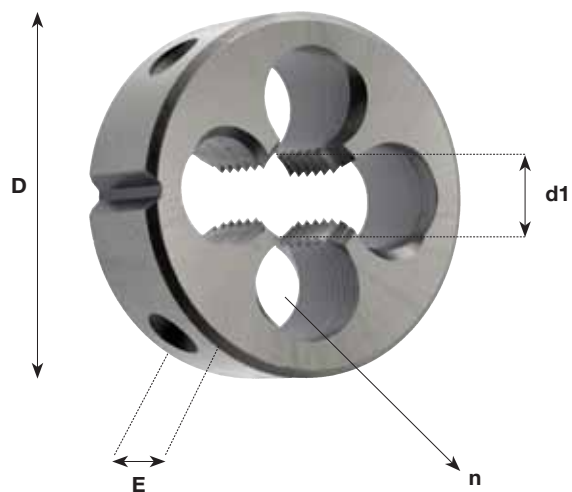
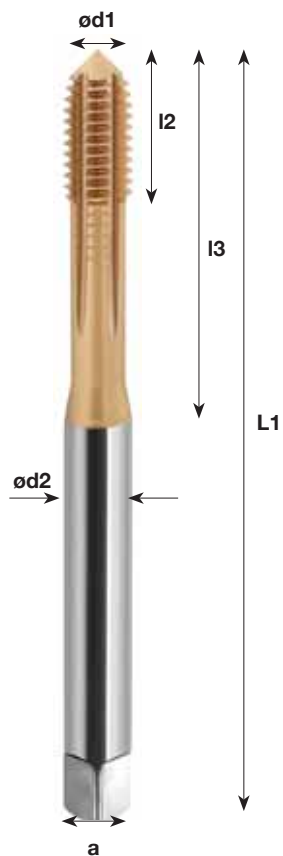
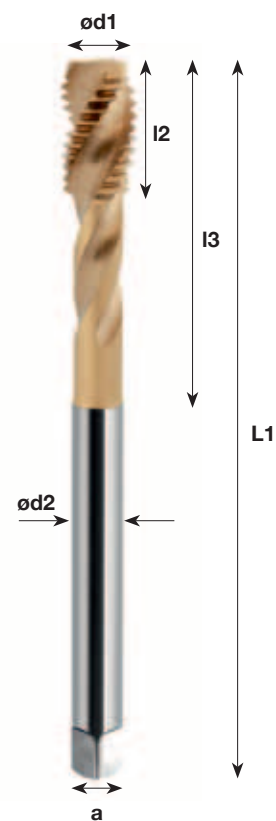
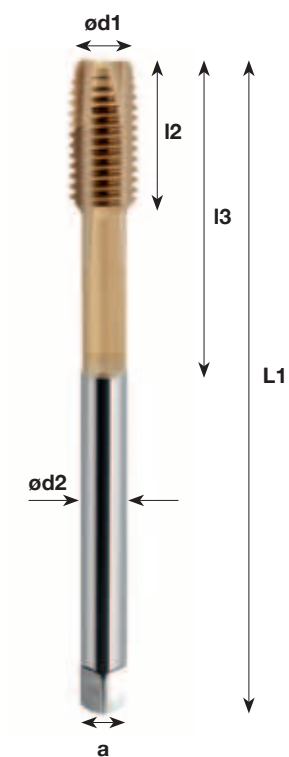

INHALTSVERZEICHNIS GEWINDEWERKZEUGE



Artikel	GH-B10001	GH-B20001	GH-B10002	GH-B20002	GH-F10001	GH-S10002
Typ	Dulo	Salo	Dulo	Salo		INOX
Gewindeart	M	M	M	M	M	M
Form	B/4-5P	C/2-3P	B/4-5P	C/2-3P	C/2-3P	2,25P
Toleranz	6H	6H	6HX	6HX	6HX	6g
DIN	371/376	371/376	371/376	371/376	371/376	13
Substrat	HSSE/PM	HSSE/PM	HSSE/PM	HSSE/PM	HSSE/PM	HSSE
Seite	68	70	72	76	80	82
P.1	●	●	●	●	●	
P.2	●	●	●	●	●	
P.3	●	●	●	●	●	
P.4	●	●	●	●	●	
P.5	●	●	●	●	●	
P.6	●	●	●	●	●	
P.7	●	●	●	●	●	
P.8	●	●	●	●	●	
P.9	●	●	●	●	●	
M.1	●	●	●	●	●	
M.2	●	●	●	●	●	
K.1	●	●	●	●		
K.2	●	●	●	●		
K.3	●	●	●	●		
N.1	●	●	●	●	●	
N.2	●	●	●	●	●	
N.3	●	●	●	●		
N.4	●	●	●	●	●	
N.5	●	●	●	●		
N.6				●		
S.1			●	●		
S.1			●	●		
H.1						
H.2						
H.3						



GH-B10001

HSSE/PM-M-MASCHINENGEWINDEBOHRER DULO

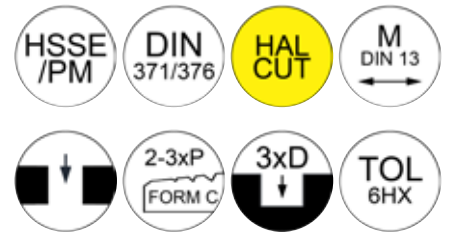

Artikel-Nr. Article-No.	M	P	d1	d2	l1	l2	l3	a	Preis/Euro Price/Euro
GH-B10001.M030B.00	M3	0,5	2,5	3,5	56	10	18	2,7	12,40 €
GH-B10001.M040B.00	M4	0,7	3,3	4,5	63	12	21	3,4	12,40 €
GH-B10001.M050B.00	M5	0,8	4,2	6	70	14	25	4,9	13,45 €
GH-B10001.M060B.00	M6	1	5	6	80	18	30	4,9	14,80 €
GH-B10001.M070B.00	M7	1	6	7	80	18	30	5,5	23,65 €
GH-B10001.M080B.00	M8	1,25	6,8	8	90	20	35	6,2	20,80 €
GH-B10001.M090B.00	M9	1,25	7,8	9	90	20	35	7	33,95 €
GH-B10001.M100B.00	M10	1,5	8,5	10	100	20	39	8	26,20 €
GH-B10001.M120B.00	M12	1,75	10,2	9	110	24		7	34,30 €
GH-B10001.M140B.00	M14	2	12	11	110	25		9	42,35 €
GH-B10001.M160B.00	M16	2	14	12	110	32		9	47,20 €
GH-B10001.M180B.00	M18	2,5	15,5	14	125	32		15,5	66,50 €
GH-B10001.M200B.00	M20	2,5	17,5	16	140	32		12	71,80 €
GH-B10001.M240B.00	M24	3	21	18	160	38		14,5	101,80€



MATERIALBESCHREIBUNG		VC
P.1	allg. Stähle/general steels <500 N/mm	20-35
P.2	allg. Stähle/general steels <650 N/mm	20-35
P.3	allg. Stähle/general steels <800 N/mm	20-30
P.4	allg. Stähle/general steels <1000 N/mm	10-25
P.5	allg. Stähle/general steels <1400 N/mm	5-15
P.6	Einsatzstähle/case hardening steels <1000 N/mm	10-25
P.7	Nitrierstähle/nitriding steels <1000 N/mm	10-25
P.8	Vergütungsstähle/heat tempered steels <850 N/mm	10-25
P.9	Werkzeugstähle (legiert und unlegiert)/tool steels <1000 N/mm	10-25
M.1	Rost- und säurebeständige Stähle <750 N/mm corrosion- and acid-resistant steels <750 N/mm	5-15
M.2	Rost- und säurebeständige Stähle <750 N/mm corrosion- and acid-resistant steels <750 N/mm	5-10
K.1	Gusseisen/cast iron <200 HB	15-25
K.2	Temperguss/malleable cast iron	10-20
K.3	Gusseisen mit Kugelgraphit/ductile cast iron	5-15
N.1	AL- und AL-Legierung/AL- and AL-alloys <5% Si	20-30
N.2	AL- und AL-Legierung/AL- and AL-alloys <10% Si	10-25
N.3	AL-Legierung/AL-alloys <10% Si	10-25
N.4	Messing, Kupfer, Bronze, Rotguss brass, copper, bronze, red brass	10-30
N.5	Duro- und Thermoplaste/duro- and thermoplastics	10-30
N.6	Grafit, GFK/graphite	
S.1	Titan und Titanlegierung/titanium and tit.-alloys	
S.2	Nickel/nickel	
H.1	gehärtete Stähle/hardened steels 45-52 HRC	
H.2	gehärtete Stähle/hardened steels 52-60 HRC	
H.3	gehärtete Stähle/hardened steels 60-65 HRC	



GH-B20001

HSSE/PM-M-MASCHINENGEWINDEBOHRER SALO

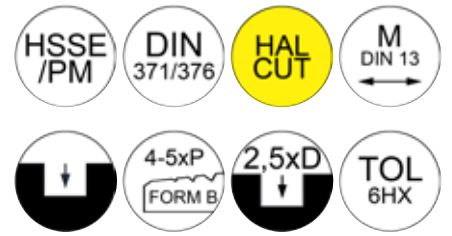

Artikel-Nr. Article-No.	M	P	d1	d2	l1	l2	l3	a	Preis/Euro Price/Euro
GH-B20001.M030B.00	M3	0,5	2,5	3,5	56	10	18	2,7	13,05 €
GH-B20001.M040B.00	M4	0,7	3,3	4,5	63	12	21	3,4	13,05 €
GH-B20001.M050B.00	M5	0,8	4,2	6	70	14	25	4,9	14,15 €
GH-B20001.M060B.00	M6	1	5	6	80	18	30	4,9	15,55 €
GH-B20001.M070B.00	M7	1	6	7	80	18	30	5,5	25,65 €
GH-B20001.M080B.00	M8	1,25	6,8	8	90	20	35	6,2	21,50 €
GH-B20001.M090B.00	M9	1,25	7,8	9	90	20	35	7	35,05 €
GH-B20001.M100B.00	M10	1,5	8,5	10	100	20	39	8	27,50 €
GH-B20001.M120B.00	M12	1,75	10,2	9	110	24		7	34,30 €
GH-B20001.M140B.00	M14	2	12	11	110	25		9	44,75 €
GH-B20001.M160B.00	M16	2	14	12	110	32		9	49,80 €
GH-B20001.M180B.00	M18	2,5	15,5	14	125	32		15,5	66,50 €
GH-B20001.M200B.00	M20	2,5	17,5	16	140	32		12	71,80 €
GH-B20001.M240B.00	M24	3	21	18	160	38		14,5	101,05 €



MATERIALBESCHREIBUNG		VC
P.1	allg. Stähle/general steels <500 N/mm	20-35
P.2	allg. Stähle/general steels <650 N/mm	20-35
P.3	allg. Stähle/general steels <800 N/mm	20-30
P.4	allg. Stähle/general steels <1000 N/mm	10-25
P.5	allg. Stähle/general steels <1400 N/mm	5-15
P.6	Einsatzstähle/case hardening steels <1000 N/mm	10-25
P.7	Nitrierstähle/nitriding steels <1000 N/mm	10-25
P.8	Vergütungsstähle/heart tempered steels <850 N/mm	10-25
P.9	Werkzeugstähle (legiert und unlegiert)/tool steels <1000 N/mm	10-25
M.1	Rost- und säurebeständige Stähle <750 N/mm corrosion- and acid-resistant steels <750 N/mm	5-15
M.2	Rost- und säurebeständige Stähle <750 N/mm corrosion- and acid-resistant steels <750 N/mm	5-10
K.1	Gusseisen/cast iron <200 HB	15-25
K.2	Temperguss/malleable cast iron	10-20
K.3	Gusseisen mit Kugelgraphit/ductile cast iron	5-15
N.1	AL- und AL-Legierung/AL- and AL-alloys <5% Si	15-25
N.2	AL- und AL-Legierung/AL- and AL-alloys <10% Si	10-20
N.3	AL-Legierung/AL-alloys <10% Si	5-15
N.4	Messing, Kupfer, Bronze, Rotguss brass, copper, bronze, red brass	10-30
N.5	Duro- und Thermoplaste/duro- and thermoplastics	10-30
N.6	Grafit, GFK/graphite	
S.1	Titan und Titanlegierung/titanium and tit.-alloys	
S.2	Nickel/nickel	
H.1	gehärtete Stähle/hardened steels 45-52 HRC	
H.2	gehärtete Stähle/hardened steels 52-60 HRC	
H.3	gehärtete Stähle/hardened steels 60-65 HRC	



GH-B10002

HSSE/PM-M-MASCHINENGEWINDEBOHRER DULO



GEWINDEWERKZEUGE

Artikel-Nr. Article-No.	M	P	d1	d2	l1	l3	a	Preis/Euro Price/Euro
GH-B10002.M010B.00	M1	0,25	0,75	2,5	40	13	2,1	46,45 €
GH-B10002.M011B.00	M1,1	0,25	0,85	2,5	40	13	2,1	46,45 €
GH-B10002.M012B.00	M1,2	0,25	0,95	2,5	40	13	2,1	46,45 €
GH-B10002.M014B.00	M1,4	0,3	1,1	2,5	40	13	2,1	46,45 €
GH-B10002.M016B.00	M1,6	0,35	1,25	2,5	40	13	2,1	46,45 €
GH-B10002.M017B.00	M1,7	0,35	1,35	2,5	40	13	2,1	46,45 €
GH-B10002.M018B.00	M1,8	0,35	1,45	2,5	40	13	2,1	46,45 €
GH-B10002.M020B.00	M2	0,4	1,6	2,8	45	13	2,1	24,45 €
GH-B10002.M022B.00	M2,2	0,45	1,75	2,8	45	13	2,1	25,60 €
GH-B10002.M023B.00	M2,3	0,4	1,9	2,8	45	13	2,1	25,60 €
GH-B10002.M025B.00	M2,5	0,45	2,05	2,8	50	14	2,1	24,45 €
GH-B10002.M026B.00	M2,6	0,45	2,15	2,8	50	13	2,1	24,45 €





MATERIALBESCHREIBUNG		VC
P.1	allg. Stähle/general steels <500 N/mm	20-40
P.2	allg. Stähle/general steels <650 N/mm	20-40
P.3	allg. Stähle/general steels <800 N/mm	15-35
P.4	allg. Stähle/general steels <1000 N/mm	15-30
P.5	allg. Stähle/general steels <1400 N/mm	10-20
P.6	Einsatzstähle/case hardening steels <1000 N/mm	15-30
P.7	Nitrierstähle/nitriding steels <1000 N/mm	15-30
P.8	Vergütungsstähle/heart tempered steels <850 N/mm	15-30
P.9	Werkzeugstähle (legiert und unlegiert)/tool steels <1000 N/mm	15-30
M.1	Rost- und säurebeständige Stähle <750 N/mm corrosion- and acid-resistant steels <750 N/mm	10-15
M.2	Rost- und säurebeständige Stähle <750 N/mm corrosion- and acid-resistant steels <750 N/mm	5-10
K.1	Gusseisen/cast iron <200 HB	20-30
K.2	Temperguss/malleable cast iron	15-30
K.3	Gusseisen mit Kugelgraphit/ductile cast iron	5-10
N.1	AL- und AL-Legierung/AL- and AL-alloys <5% Si	20-30
N.2	AL- und AL-Legierung/AL- and AL-alloys <10% Si	10-30
N.3	AL-Legierung/AL-alloys <10% Si	10-20
N.4	Messing, Kupfer, Bronze, Rotguss brass, copper, bronze, red brass	10-30
N.5	Duro- und Thermoplaste/duro- and thermoplastics	10-30
N.6	Grafit, GFK/graphite	
S.1	Titan und Titanlegierung/titanium and tit.-alloys	1-8
S.2	Nickel/nickel	1-8
H.1	gehärtete Stähle/hardened steels 45-52 HRC	
H.2	gehärtete Stähle/hardened steels 52-60 HRC	
H.3	gehärtete Stähle/hardened steels 60-65 HRC	



GH-B10002

HSSE/PM-M-MASCHINENGEWINDEBOHRER DULO

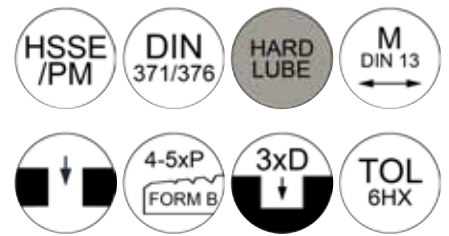

GEWINDEWERKZEUGE

Artikel-Nr. Article-No.	M	P	d1	d2	l1	l2	l3	a	Preis/Euro Price/Euro
GH-B10002.M030B.00	M3	0,5	2,5	3,5	56	5	18	2,7	18,30 €
GH-B10002.M040B.00	M4	0,7	3,3	4,5	63	7	21	3,4	18,40 €
GH-B10002.M050B.00	M5	0,8	4,2	6	70	8	25	4,9	18,50 €
GH-B10002.M060B.00	M6	1	5	6	80	10	30	4,9	20,45 €
GH-B10002.M080B.00	M8	1,25	6,8	8	90	13	35	6,2	28,80 €
GH-B10002.M100B.00	M10	1,5	8,5	10	100	15	39	8	36,50 €
GH-B10002.M120B.00	M12	1,75	10,2	9	110	18		7	49,30 €
GH-B10002.M160B.00	M16	2	14	12	110	20		9	62,40 €
GH-B10002.M200B.00	M20	2,5	17,5	16	140	25		12	110,10 €
GH-B10002.M240B.00	M24	3	21	18	160	30		14,5	142,15 €





MATERIALBESCHREIBUNG		VC
P.1	allg. Stähle/general steels <500 N/mm	20-40
P.2	allg. Stähle/general steels <650 N/mm	20-40
P.3	allg. Stähle/general steels <800 N/mm	15-35
P.4	allg. Stähle/general steels <1000 N/mm	15-30
P.5	allg. Stähle/general steels <1400 N/mm	10-20
P.6	Einsatzstähle/case hardening steels <1000 N/mm	15-30
P.7	Nitrierstähle/nitriding steels <1000 N/mm	15-30
P.8	Vergütungsstähle/heart tempered steels <850 N/mm	15-30
P.9	Werkzeugstähle (legiert und unlegiert)/tool steels <1000 N/mm	15-30
M.1	Rost- und säurebeständige Stähle <750 N/mm corrosion- and acid-resistant steels <750 N/mm	10-15
M.2	Rost- und säurebeständige Stähle <750 N/mm corrosion- and acid-resistant steels <750 N/mm	5-10
K.1	Gusseisen/cast iron <200 HB	20-30
K.2	Temperguss/malleable cast iron	15-30
K.3	Gusseisen mit Kugelgraphit/ductile cast iron	5-10
N.1	AL- und AL-Legierung/AL- and AL-alloys <5% Si	20-30
N.2	AL- und AL-Legierung/AL- and AL-alloys <10% Si	10-30
N.3	AL-Legierung/AL-alloys <10% Si	10-20
N.4	Messing, Kupfer, Bronze, Rotguss brass, copper, bronze, red brass	10-30
N.5	Duro- und Thermoplaste/duro- and thermoplastics	10-30
N.6	Grafit, GFK/graphite	
S.1	Titan und Titanlegierung/titanium and tit.-alloys	1-8
S.2	Nickel/nickel	1-8
H.1	gehärtete Stähle/hardened steels 45-52 HRC	
H.2	gehärtete Stähle/hardened steels 52-60 HRC	
H.3	gehärtete Stähle/hardened steels 60-65 HRC	



GH-B20002

HSSE/PM-M-MASCHINENGEWINDEBOHRER SALO



GEWINDEWERKZEUGE

Artikel-Nr. Article-No.	M	P	d1	d2	l1	l2	l3	a	Preis/Euro Price/Euro
GH-B20002.M010B.00	M1	0,25	0,75	2,5	40	6	13	2,1	46,45 €
GH-B20002.M011B.00	M1,1	0,25	0,85	2,5	40	6	13	2,1	46,45 €
GH-B20002.M012B.00	M1,2	0,25	0,95	2,5	40	6	13	2,1	46,45 €
GH-B20002.M014B.00	M1,4	0,3	1,1	2,5	40	8	13	2,1	46,45 €
GH-B20002.M016B.00	M1,6	0,35	1,25	2,5	40	8	13	2,1	46,45 €
GH-B20002.M017B.00	M1,7	0,35	1,35	2,5	40	8	13	2,1	46,45 €
GH-B20002.M018B.00	M1,8	0,35	1,45	2,5	40	8	13	2,1	46,45 €
GH-B20002.M020B.00	M2	0,4	1,6	2,8	45	10	13	2,1	26,85 €
GH-B20002.M022B.00	M2,2	0,45	1,75	2,8	45	10	13	2,1	28,25 €
GH-B20002.M023B.00	M2,3	0,4	1,9	2,8	45	10	13	2,1	28,25 €
GH-B20002.M025B.00	M2,5	0,45	2,05	2,8	50	5	14	2,1	26,85 €
GH-B20002.M026B.00	M2,6	0,45	2,15	2,8	50	5	14	2,1	27,20 €





MATERIALBESCHREIBUNG		VC
P.1	allg. Stähle/general steels <500 N/mm	20-40
P.2	allg. Stähle/general steels <650 N/mm	20-40
P.3	allg. Stähle/general steels <800 N/mm	15-35
P.4	allg. Stähle/general steels <1000 N/mm	15-30
P.5	allg. Stähle/general steels <1400 N/mm	10-20
P.6	Einsatzstähle/case hardening steels <1000 N/mm	15-30
P.7	Nitrierstähle/nitriding steels <1000 N/mm	15-30
P.8	Vergütungsstähle/heart tempered steels <850 N/mm	15-30
P.9	Werkzeugstähle (legiert und unlegiert)/tool steels <1000 N/mm	15-30
M.1	Rost- und säurebeständige Stähle <750 N/mm corrosion- and acid-resistant steels <750 N/mm	10-15
M.2	Rost- und säurebeständige Stähle <750 N/mm corrosion- and acid-resistant steels <750 N/mm	5-10
K.1	Gusseisen/cast iron <200 HB	20-30
K.2	Temperguss/malleable cast iron	15-30
K.3	Gusseisen mit Kugelgraphit/ductile cast iron	5-10
N.1	AL- und AL-Legierung/AL- and AL-alloys <5% Si	20-30
N.2	AL- und AL-Legierung/AL- and AL-alloys <10% Si	15-30
N.3	AL-Legierung/AL-alloys <10% Si	5-10
N.4	Messing, Kupfer, Bronze, Rotguss brass, copper, bronze, red brass	20-30
N.5	Duro- und Thermoplaste/duro- and thermoplastics	15-30
N.6	Grafit, GFK/graphite	5-10
S.1	Titan und Titanlegierung/titanium and tit.-alloys	1-8
S.2	Nickel/nickel	1-8
H.1	gehärtete Stähle/hardened steels 45-52 HRC	
H.2	gehärtete Stähle/hardened steels 52-60 HRC	
H.3	gehärtete Stähle/hardened steels 60-65 HRC	



GH-B20002

HSSE/PM-M-MASCHINENGEWINDEBOHRER SALO



GEWINDEWERKZEUGE

Artikel-Nr. Article-No.	M	P	d1	d2	l1	l2	l3	a	Preis/Euro Price/Euro
GH-B20002.M030B.00	M3	0,5	2,5	3,5	56	5	18	2,7	19,95 €
GH-B20002.M040B.00	M4	0,7	3,3	4,5	63	7	21	3,4	20,10 €
GH-B20002.M050B.00	M5	0,8	4,2	6	70	8	25	4,9	20,20 €
GH-B20002.M060B.00	M6	1	5	6	80	10	30	4,9	22,15 €
GH-B20002.M080B.00	M8	1,25	6,8	8	90	13	35	6,2	31,15 €
GH-B20002.M100B.00	M10	1,5	8,5	10	100	15	39	8	39,70 €
GH-B20002.M120B.00	M12	1,75	10,2	9	110	18		7	51,70 €
GH-B20002.M160B.00	M16	2	14	12	110	20		9	78,50 €
GH-B20002.M200B.00	M20	2,5	17,5	16	140	25		12	122,35 €
GH-B20002.M240B.00	M24	3	21	18	160	30		14,5	151,70 €





MATERIALBESCHREIBUNG		VC
P.1	allg. Stähle/general steels <500 N/mm	20-40
P.2	allg. Stähle/general steels <650 N/mm	20-40
P.3	allg. Stähle/general steels <800 N/mm	15-35
P.4	allg. Stähle/general steels <1000 N/mm	15-30
P.5	allg. Stähle/general steels <1400 N/mm	10-20
P.6	Einsatzstähle/case hardening steels <1000 N/mm	15-30
P.7	Nitrierstähle/nitriding steels <1000 N/mm	15-30
P.8	Vergütungsstähle/heart tempered steels <850 N/mm	15-30
P.9	Werkzeugstähle (legiert und unlegiert)/tool steels <1000 N/mm	15-30
M.1	Rost- und säurebeständige Stähle <750 N/mm corrosion- and acid-resistant steels <750 N/mm	10-15
M.2	Rost- und säurebeständige Stähle <750 N/mm corrosion- and acid-resistant steels <750 N/mm	5-10
K.1	Gusseisen/cast iron <200 HB	20-30
K.2	Temperguss/malleable cast iron	15-30
K.3	Gusseisen mit Kugelgraphit/ductile cast iron	5-10
N.1	AL- und AL-Legierung/AL- and AL-alloys <5% Si	20-30
N.2	AL- und AL-Legierung/AL- and AL-alloys <10% Si	15-30
N.3	AL-Legierung/AL-alloys <10% Si	5-10
N.4	Messing, Kupfer, Bronze, Rotguss brass, copper, bronze, red brass	20-30
N.5	Duro- und Thermoplaste/duro- and thermoplastics	15-30
N.6	Grafit, GFK/graphite	5-10
S.1	Titan und Titanlegierung/titanium and tit.-alloys	1-8
S.2	Nickel/nickel	1-8
H.1	gehärtete Stähle/hardened steels 45-52 HRC	
H.2	gehärtete Stähle/hardened steels 52-60 HRC	
H.3	gehärtete Stähle/hardened steels 60-65 HRC	



GH-F10001

HSSE/PM-M-GEWINDEFORMER

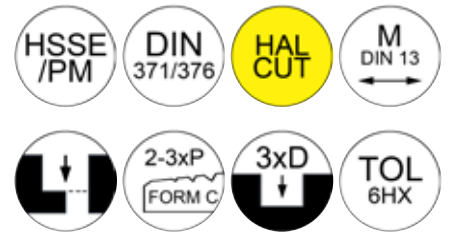

Artikel-Nr. Article-No.	M	P	d1	d2	l1	l2	l3	a	Preis/Euro Price/Euro
GH-F10001.M020B.00	M2	0,4	1,85	2,8	45	8	8	2,1	34,60 €
GH-F10001.M030B.00	M3	0,5	2,8	3,5	56	10	18	2,7	27,20 €
GH-F10001.M040B.00	M4	0,7	3,7	4,5	63	7	21	3,4	18,70 €
GH-F10001.M050B.00	M5	0,8	4,65	6	70	8	25	4,9	20,40 €
GH-F10001.M060B.00	M6	1	5,6	6	80	10	30	4,9	21,80 €
GH-F10001.M080B.00	M8	1,25	7,45	8	90	13	35	6,2	29,90 €
GH-F10001.M100B.00	M10	1,5	9,35	10	100	15	39	8	35,60 €
GH-F10001.M120B.00	M12	1,75	11,25	9	110	18		7	46,90 €
GH-F10001.M140B.00	M14	2	13,1	11	110	20		9	63,70 €
GH-F10001.M160B.00	M16	2	15,1	12	110	20		9	70,60 €
GH-F10001.M180B.00	M18	2,5	16,85	14	125	32		11	155,00 €
GH-F10001.M200B.00	M20	2,5	18,85	16	140	32		12	148,50 €



MATERIALBESCHREIBUNG		VC
P.1	allg. Stähle/general steels <500 N/mm	20-40
P.2	allg. Stähle/general steels <650 N/mm	20-40
P.3	allg. Stähle/general steels <800 N/mm	20-40
P.4	allg. Stähle/general steels <1000 N/mm	15-35
P.5	allg. Stähle/general steels <1400 N/mm	10-30
P.6	Einsatzstähle/case hardening steels <1000 N/mm	15-35
P.7	Nitrierstähle/nitriding steels <1000 N/mm	15-35
P.8	Vergütungsstähle/heart tempered steels <850 N/mm	15-35
P.9	Werkzeugstähle (legiert und unlegiert)/tool steels <1000 N/mm	15-35
M.1	Rost- und säurebeständige Stähle <750 N/mm corrosion- and acid-resistant steels <750 N/mm	15-25
M.2	Rost- und säurebeständige Stähle <750 N/mm corrosion- and acid-resistant steels <750 N/mm	10-20
K.1	Gusseisen/cast iron <200 HB	
K.2	Temperguss/malleable cast iron	
K.3	Gusseisen mit Kugelgraphit/ductile cast iron	
N.1	AL- und AL-Legierung/AL- and AL-alloys <5% Si	20-40
N.2	AL- und AL-Legierung/AL- and AL-alloys <10% Si	20-30
N.3	AL-Legierung/AL-alloys <10% Si	
N.4	Messing, Kupfer, Bronze, Rotguss brass, copper, bronze, red brass	20-40
N.5	Duro- und Thermoplaste/duro- and thermoplastics	
N.6	Grafit, GFK/graphite	
S.1	Titan und Titanlegierung/titanium and 5tit.-alloys	
S.2	Nickel/nickel	
H.1	gehärtete Stähle/hardened steels 45-52 HRC	
H.2	gehärtete Stähle/hardened steels 52-60 HRC	
H.3	gehärtete Stähle/hardened steels 60-65 HRC	



GH-S10002

HSSE-M SCHNEIDEISEN MIT SCHÄLAUSSCHNITT (INOX)

DIN
13

BLANK
NO COATING

M
DIN 13

TOL
6g

INOX

HSS-E



GEWINDEWERKZEUGE

Artikel-Nr. Article-No.	M	P	DXE	n	Preis/Euro Price/Euro
GH-S10002.M030U.00	M3	0,5	20x5	3	17,30 €
GH-S10002.M040U.00	M4	0,7	20x5	3	16,30 €
GH-S10002.M050U.00	M5	0,8	20x7	4	16,70 €
GH-S10002.M060U.00	M6	1	20x7	4	16,70 €
GH-S10002.M070U.00	M7	1	25x9	4	22,10 €
GH-S10002.M080U.00	M8	1,25	25x9	5	18,70 €
GH-S10002.M100U.00	M10	1,5	30x11	5	23,90 €
GH-S10002.M120U.00	M12	1,75	38x14	5	30,50 €
GH-S10002.M140U.00	M14	2	38x14	5	30,50 €
GH-S10002.M160U.00	M16	2	45x18	5	54,90 €
GH-S10002.M200U.00	M20	2,5	45x18	5	54,90 €

INOX-STAR



HALLAS
TOOLS

REIB-, SENK- UND ENTGRATWERKZEUGE



BESCHREIBUNG WERKZEUGE

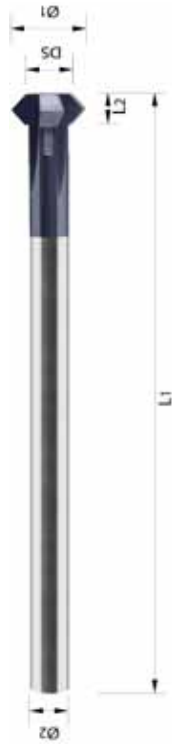

INHALTSVERZEICHNIS ENTGRATWERKZEUGE



Artikel	RV-VE4501	RV-E06001	RV-E09001
Substrat	VHM	VHM	VHM
Drm.-Bereich	2-16	4-20	1-20
Winkel	45°	60°	90°
DIN	WN	WN	WN
Zähnezahl	3-4	4-6	3-6
Seite	86	88	90
P.1	●	●	●
P.2	●	●	●
P.3	●	●	●
P.4	●	●	●
P.5	●	●	●
P.6	●	●	●
P.7	●	●	●
P.8	●	●	●
P.9	●	●	●
M.1	●	●	●
M.2	●	●	●
K.1	●	●	●
K.2	●	●	●
K.3	●	●	●
N.1	●	●	●
N.2	●	●	●
N.3	●	●	●
N.4	●	●	●
N.5	●		
N.6	●		
S.1		●	●
S.1		●	●
H.1			
H.2			
H.3			





RV-VE4501

VHM-VOR- UND RÜCKWÄRTSENTGRATER 90° (45°)



Artikel-Nr. Article-No.	D1	D2	DS	L2	L1	L3	D3	Z	Preis/Euro Price/Euro
RV-VE4501.0200B.00	2	6		1,40	100	10	1,20	3	53,46 €
RV-VE4501.0300B.00	3	6		2,00	100	10	2,00	4	53,46 €
RV-VE4501.0400B.00	4	6		3,00	100	13	2,00	4	55,58 €
RV-VE4501.0600B.00	6	6		4,00	100	19	4,00	4	62,00 €
RV-VE4501.0800B.00	8	6	3,60	3,20	100			4	84,06 €
RV-VE4501.1000B.00	10	6	5,40	4,30	100			4	103,01 €
RV-VE4501.1200B.00	12	6	7,00	5,00	100			4	123,14 €
RV-VE4501.1600B.00	16	10	6,00	8,00	100			4	175,21 €



RV-VE4501

VHM-VOR- UND RÜCKWÄRTSENTGRATER 90° (45°)

MATERIALBESCHREIBUNG

		Vc m/min von/bis		f mm/U		f mm/U		f mm/U		f mm/U		f mm/U	
				Ø 1,0-4,0 von/bis		Ø 4,0-6,0 von/bis		Ø 6,0-8,0 von/bis		Ø 8,0-10,0 von/bis		Ø 10,0-12,0 von/bis	
P.1	<500N/mm	60	80	0,004	0,007	0,007	0,014	0,014	0,018	0,018	0,022	0,022	0,030
P.2	<650N/mm	60	80	0,002	0,006	0,006	0,014	0,014	0,018	0,018	0,022	0,022	0,030
P.3	<800N/mm	60	80	0,002	0,006	0,006	0,014	0,014	0,018	0,018	0,022	0,022	0,030
P.4	<1000N/mm	50	70	0,022	0,006	0,006	0,014	0,014	0,018	0,018	0,022	0,022	0,030
P.5	<1400N/mm	30	50	0,004	0,006	0,006	0,010	0,010	0,012	0,012	0,014	0,014	0,021
P.6	Einsatz-ST <1000N/mm	40	60	0,004	0,006	0,006	0,010	0,010	0,012	0,012	0,014	0,014	0,021
P.7	Nitrier-ST <1000N/mm	35	55	0,004	0,006	0,006	0,010	0,010	0,012	0,012	0,014	0,014	0,021
P.8	Vergütung-ST 850N/mm	35	55	0,004	0,006	0,006	0,010	0,010	0,012	0,012	0,014	0,014	0,021
P.9	Werkzeug-ST 1000N/mm	25	40	0,004	0,006	0,006	0,010	0,010	0,012	0,012	0,014	0,014	0,021
M.1	VA <750N/mm	35	55	0,004	0,006	0,006	0,010	0,010	0,012	0,012	0,014	0,014	0,021
M.2	VA >750N/mm	30	50	0,002	0,006	0,006	0,010	0,010	0,012	0,012	0,014	0,014	0,021
K.1	Gusseisen <200HB	30	50	0,004	0,007	0,007	0,014	0,014	0,018	0,018	0,022	0,022	0,030
K.2	Temperguss	30	50	0,004	0,007	0,007	0,014	0,014	0,018	0,018	0,022	0,022	0,030
K.3	Gusseisen mit Kugelgrafit	30	50	0,004	0,007	0,007	0,014	0,014	0,018	0,018	0,022	0,022	0,030
N.1	AL <5%	220	250	0,006	0,009	0,009	0,015	0,015	0,020	0,020	0,025	0,025	0,035
N.2	AL <10%	110	130	0,006	0,009	0,009	0,015	0,015	0,020	0,020	0,025	0,025	0,035
N.3	AL >10%	70	100	0,006	0,009	0,009	0,015	0,015	0,020	0,020	0,025	0,025	0,035
N.4	Ms, Cu, Bronze, Rotguss	60	80	0,004	0,007	0,007	0,014	0,014	0,018	0,018	0,022	0,022	0,030
N.5	Duro-Thermoplast	110	130	0,004	0,007	0,007	0,014	0,014	0,018	0,018	0,022	0,022	0,030
N.6	Grafit, GFK	30	50	0,004	0,007	0,007	0,014	0,014	0,018	0,018	0,022	0,022	0,030
S.1	Titan												
S.2	Nickel												
H.1	45-52 HRC												
H.2	52-60 HRC												
H.3	60-65 HRC												



RV-E06001
VHM-ENTGRATER 60°

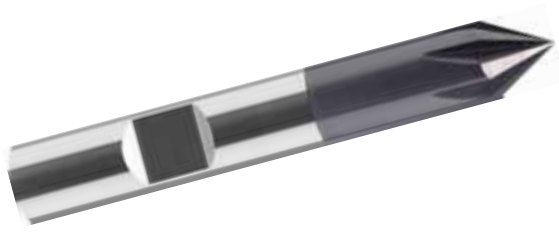
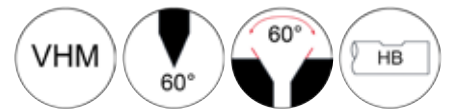

Artikel-Nr. Article-No.	D1	D2 h6	l2	l1	z	Preis/Euro Price/Euro
RV-E06001.0400B.00	4	4	2	54	4	21,38 €
RV-E06001.0600B.00	6	6	3	57	4	27,52 €
RV-E06001.0800B.00	8	8	4	63	5	33,64 €
RV-E06001.1000B.00	10	10	5	72	6	46,15 €
RV-E06001.1200B.00	12	12	6	83	6	66,72 €
RV-E06001.1600B.00	16	16	8	92	6	116,74 €
RV-E06001.2000B.00	20	20	10	104	6	169,55 €



RV-E06001

VHM-ENTGRATER 60°

MATERIALBESCHREIBUNG

		Vc m/min	f mm/U		f mm/U		f mm/U		f mm/U		f mm/U	
			Ø 1,0-4,0 von/bis	Ø 4,0-8,0 von/bis	Ø 8,0-12,0 von/bis	Ø 12,0-16,0 von/bis	Ø 16,0-20,0 von/bis					
P.1	<500N/mm	190	0,020	0,040	0,040	0,070	0,070	0,120	0,120	0,150	0,150	0,170
P.2	<650N/mm	170	0,020	0,040	0,040	0,070	0,070	0,120	0,120	0,150	0,150	0,170
P.3	<800N/mm	170	0,020	0,040	0,040	0,070	0,070	0,120	0,120	0,150	0,150	0,170
P.4	<1000N/mm	140	0,020	0,040	0,040	0,070	0,070	0,120	0,120	0,150	0,150	0,170
P.5	<1400N/mm	85	0,010	0,020	0,020	0,040	0,040	0,060	0,060	0,080	0,080	0,120
P.6	Einsatz-ST <1000N/mm	120	0,010	0,020	0,020	0,050	0,050	0,070	0,070	0,100	0,100	0,130
P.7	Nitrier-ST <1000N/mm	120	0,010	0,020	0,020	0,050	0,050	0,070	0,070	0,100	0,100	0,130
P.8	Vergütung-ST 850N/mm	160	0,010	0,030	0,030	0,050	0,050	0,070	0,070	0,100	0,100	0,130
P.9	Werkzeug-ST 1000N/mm	95	0,010	0,020	0,020	0,040	0,040	0,060	0,060	0,080	0,080	0,120
M.1	VA <750N/mm	110	0,010	0,020	0,020	0,040	0,040	0,050	0,050	0,070	0,070	0,080
M.2	VA >750N/mm	75	0,010	0,020	0,020	0,030	0,030	0,040	0,040	0,060	0,060	0,080
K.1	Gusseisen <200HB	150	0,010	0,030	0,030	0,040	0,040	0,070	0,070	0,080	0,080	0,100
K.2	Temperguss	70	0,020	0,040	0,040	0,060	0,060	0,090	0,090	0,120	0,120	0,150
K.3	Gusseisen mit Kugelgraphit	100	0,020	0,040	0,040	0,060	0,060	0,090	0,090	0,120	0,120	0,150
N.1	AL <5%	700	0,020	0,040	0,040	0,070	0,070	0,120	0,120	0,150	0,150	0,170
N.2	AL <10%	700	0,020	0,040	0,040	0,070	0,070	0,120	0,120	0,150	0,150	0,170
N.3	AL >10%	40	0,020	0,040	0,040	0,070	0,070	0,120	0,120	0,150	0,150	0,170
N.4	Ms, Cu, Bronze, Rotguss	300	0,020	0,040	0,040	0,070	0,070	0,120	0,120	0,150	0,150	0,170
N.5	Duro-Thermoplast											
N.6	Grafit, GFK											
S.1	Titan	60	0,010	0,020	0,020	0,040	0,040	0,070	0,070	0,090	0,090	0,110
S.2	Nickel	60	0,010	0,020	0,020	0,040	0,040	0,070	0,070	0,090	0,090	0,110
H.1	45-52 HRC											
H.2	52-60 HRC											
H.3	60-65 HRC											



RV-E09001

VHM-ENTGRATER 90°

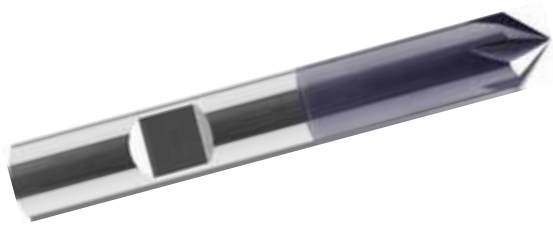
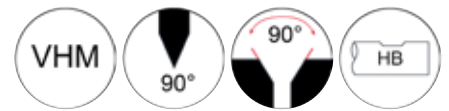

Artikel-Nr. Article-No.	D1	D2 h6	l2	l1	z	Preis/Euro Price/Euro
RV-E09001.0100B.00	1	3	0,5	38	3	21,38 €
RV-E09001.0200B.00	2	3	1	38	3	21,38 €
RV-E09001.0300B.00	3	3	1,5	38	4	21,38 €
RV-E09001.0400B.00	4	4	2	54	4	23,52 €
RV-E09001.0600B.00	6	6	3	57	4	25,02 €
RV-E09001.0800B.00	8	8	4	63	5	33,14 €
RV-E09001.1000B.00	10	10	5	72	6	44,48 €
RV-E09001.1200B.00	12	12	6	83	6	63,93 €
RV-E09001.1600B.00	16	16	8	92	6	113,96 €
RV-E09001.2000B.00	20	20	10	104	6	175,11 €



RV-E09001 VHM-ENTGRATER 90°

MATERIALBESCHREIBUNG

		Vc m/min	f mm/U		f mm/U		f mm/U		f mm/U		f mm/U	
			Ø 1,0-4,0 von/bis	Ø 4,0-8,0 von/bis	Ø 8,0-12,0 von/bis	Ø 12,0-16,0 von/bis	Ø 16,0-20,0 von/bis					
P.1	<500N/mm	120	0,010	0,030	0,030	0,060	0,060	0,100	0,100	0,120	0,120	0,140
P.2	<650N/mm	05	0,010	0,030	0,030	0,060	0,060	0,100	0,100	0,120	0,120	0,140
P.3	<800N/mm	95	0,010	0,030	0,030	0,060	0,060	0,100	0,100	0,120	0,120	0,140
P.4	<1000N/mm	90	0,010	0,030	0,030	0,060	0,060	0,100	0,100	0,120	0,120	0,140
P.5	<1400N/mm	80	0,010	0,020	0,020	0,040	0,040	0,070	0,070	0,090	0,090	0,100
P.6	Einsatz-ST <1000N/mm	80	0,010	0,020	0,020	0,040	0,040	0,070	0,070	0,100	0,100	0,100
P.7	Nitrier-ST <1000N/mm	80	0,010	0,020	0,020	0,040	0,040	0,070	0,070	0,100	0,100	0,100
P.8	Vergütung-ST 850N/mm	100	0,010	0,020	0,020	0,040	0,040	0,070	0,070	0,100	0,100	0,100
P.9	Werkzeug-ST 1000N/mm	70	0,010	0,020	0,020	0,040	0,040	0,070	0,070	0,090	0,090	0,100
M.1	VA <750N/mm	80	0,005	0,015	0,015	0,030	0,030	0,040	0,040	0,050	0,050	0,060
M.2	VA >750N/mm	60	0,005	0,010	0,010	0,030	0,030	0,040	0,040	0,050	0,050	0,060
K.1	Gusseisen <200HB	120	0,010	0,020	0,020	0,040	0,040	0,060	0,060	0,070	0,070	0,090
K.2	Temperguss	60	0,010	0,030	0,030	0,050	0,050	0,070	0,070	0,090	0,090	0,120
K.3	Gusseisen mit Kugelgrafit	90	0,010	0,030	0,030	0,050	0,050	0,070	0,070	0,090	0,090	0,120
N.1	AL <5%	300	0,010	0,030	0,030	0,060	0,060	0,100	0,100	0,120	0,120	0,140
N.2	AL <10%	280	0,010	0,030	0,030	0,060	0,060	0,100	0,100	0,120	0,120	0,140
N.3	AL >10%	200	0,010	0,030	0,030	0,060	0,060	0,100	0,100	0,120	0,120	0,140
N.4	Ms, Cu, Bronze, Rotguss	200	0,010	0,030	0,030	0,060	0,060	0,100	0,100	0,120	0,120	0,140
N.5	Duro-Thermoplast											
N.6	Grafit, GFK											
S.1	Titan	40	0,005	0,015	0,015	0,030	0,030	0,060	0,060	0,070	0,070	0,090
S.2	Nickel	40	0,005	0,015	0,015	0,030	0,030	0,060	0,060	0,070	0,070	0,090
H.1	45-52 HRC											
H.2	52-60 HRC											
H.3	60-65 HRC											



**HALLAS
TOOLS**



INHALTSVERZEICHNIS REIBAHLEN



Artikel	RV-R01001	RV-R01002	RV-R12001	RV-R11001	RV-R01003	RH-RA005	RH-R01006	RH-R01007
Substrat	VHM	VHM	VHM	VHM	VHM	HSS-E	HSS-E	HSS-E
Drm.-Bereich	0,1-20,1	1,10-20,1	2,95-16,25	2,90-14,1	1,0-12,0	1,5-20,0	0,9-13,2	1,0-20,0
Drall	Linksdrall	Rechtsdrall	gerade genutet	gerade genutet	Linksdrall	Linksdrall	Linksdrall	Linksdrall
DIN	WN	WN	WN	WN	DIN 212	DIN 8089	DIN 212	DIN 212
Art	1/100	1/100	1/100	1/100	H7	H7	1/100	H7
Seite	94	97	100	102	104	110	112	114
P.1	●	●	●	●	●	●	●	●
P.2	●	●	●	●	●	●	●	●
P.3	●	●	●	●	●	●	●	●
P.4	●	●	●	●	●	●	●	●
P.5	●	●	●	●	●	●	●	●
P.6	●	●	●	●	●	●	●	●
P.7	●	●	●	●	●	●	●	●
P.8	●	●	●	●	●	●	●	●
P.9	●	●	●	●	●	●	●	●
M.1	●	●	●	●	●	●	●	●
M.2	●	●	●	●	●	●	●	●
K.1	●	●	●	●	●	●	●	●
K.2	●	●	●	●	●	●	●	●
K.3								
N.1	●	●			●	●	●	●
N.2	●	●			●	●	●	●
N.3	●	●			●			
N.4	●	●			●	●	●	●
N.5	●	●			●			
N.6	●	●			●			
S.1						●	●	●
S.1								
H.1								
H.2								
H.3								



RV-R01001

VHM-MASCHINENREIBAHLE DULO 1/100 RECHTSSCH./LINKSDRALL

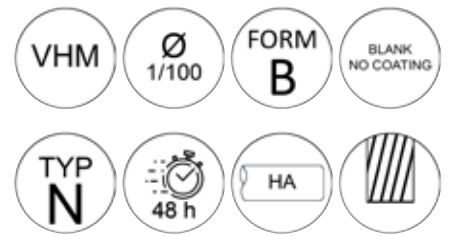

Artikel-Nr. Article-No.	Drm.	Schneid- denlänge	Nutz- länge	Gesamt- länge	Schaft- drm.	Zähne- zahl	Preis €/1-4 St.	Preis €/5-9 St.	Preis €/10-49 St.
RV-R01001.00100-00190.00	0,10-0,19	10xD	10xD	35	1,5	3	125,02 €	113,67 €	109,25 €
RV-R01001.00200-00290.00	0,20-0,29	10xD	10xD	35	1,5	3	113,67 €	103,33 €	99,31 €
RV-R01001.00300-00480.00	0,30-0,48	5	10	35	1,5	4	103,36 €	93,94 €	90,25 €
RV-R01001.00490-00530.00	0,49-0,53	5	10	35	1,5	4	103,36 €	93,94 €	90,25 €
RV-R01001.00540-00570.00	0,54-0,57	5	10	35	1,5	4	99,57 €	90,55 €	85,87 €
RV-R01001.00580-00690.00	0,58-0,69	6	12	35	1,5	4	93,94 €	85,40 €	82,05 €
RV-R01001.00700-00790.00	0,70-0,79	6	12	35	1,5	4	81,22 €	78,64 €	75,98 €
RV-R01001.00800-00870.00	0,80-0,87	6	15	35	1,5	4	69,86 €	67,58 €	65,32 €
RV-R01001.00880-00970.00	0,88-0,97	8	15	35	1,5	4	67,00 €	64,82 €	62,68 €
RV-R01001.00980-01170.00	0,98-1,17	10	17	35	1,5	4	62,71 €	60,69 €	58,66 €
RV-R01001.01180-01480.00	1,18-1,48	12	23	40	1,5	4	59,86 €	57,93 €	56,00 €
RV-R01001.01490-01980.00	1,49-1,98	16	28	45	2	4	57,01 €	55,17 €	53,32 €
RV-R01001.01990-02070.00	1,99-2,07	18	31	50	2	4	57,01 €	55,17 €	53,32 €
RV-R01001.02080-02370.00	2,08-2,37	18	31	50	3	4	57,01 €	55,17 €	53,32 €
RV-R01001.02380-02670.00	2,38-2,67	20	34	55	3	4	57,01 €	55,17 €	53,32 €
RV-R01001.02680-02980.00	2,68-2,98	20	39	60	3	4	59,86 €	57,93 €	56,00 €
RV-R01001.02990-03070.00	2,99-3,07	20	39	60	3	6	59,86 €	57,93 €	56,00 €
RV-R01001.03080-03670.00	3,08-3,67	22	37	60	4	6	59,86 €	57,93 €	56,00 €
RV-R01001.03680-04070.00	3,68-4,07	24	40	65	4	6	62,71 €	60,69 €	58,66 €
RV-R01001.04080-04870.00	4,08-4,87	24	40	65	5	6	68,41 €	66,19 €	64,01 €
RV-R01001.04880-05200.00	4,88-5,20	26	48	75	5	6	76,96 €	74,49 €	72,00 €
RV-R01001.05210-05870.00	5,21-5,87	26	48	75	5	6	82,67 €	79,99 €	77,31 €
RV-R01001.05880-06170.00	5,88-6,17	26	48	75	6	6	91,22 €	88,26 €	85,33 €
RV-R01001.06180-06600.00	6,18-6,60	30	49	80	6	6	96,91 €	93,82 €	90,68 €
RV-R01001.06610-06870.00	6,61-6,87	30	49	80	6	6	102,60 €	99,30 €	95,97 €
RV-R01001.06880-07200.00	6,88-7,20	35	59	95	7	6	111,15 €	107,56 €	103,98 €
RV-R01001.07210-07870.00	7,21-7,87	35	59	95	7	6	125,41 €	121,38 €	117,32 €
RV-R01001.07880-08200.00	7,88-8,20	35	64	100	8	6	136,79 €	132,40 €	127,97 €
RV-R01001.08210-08700.00	8,21-8,70	35	64	100	8	6	151,07 €	146,19 €	141,33 €
RV-R01001.08710-08870.00	8,71-8,87	35	64	100	8	6	156,74 €	151,71 €	146,63 €
RV-R01001.08880-09200.00	8,88-9,20	35	64	100	9	6	159,60 €	154,45 €	149,31 €
RV-R01001.09210-09700.00	9,21-9,70	35	64	100	9	6	165,29 €	159,99 €	154,67 €
RV-R01001.09710-09870.00	9,71-9,87	35	64	100	9	6	176,72 €	171,03 €	165,31 €

REIBAHLEN



RV-R01001 VHM-MASCHINENREIBAHLE DULO 1/100 RECHTSSCH./LINKSDRALL

RV-R01001.09880-10700.00	9,88-10,70	35	64	100	10	6	190,95 €	184,81 €	178,65 €
RV-R01001.10710-10870.00	10,71-10,87	35	64	100	10	6	196,67 €	190,35 €	183,98 €
RV-R01001.10880-11200.00	10,88-11,20	35	64	100	11	6	202,36 €	195,84 €	189,30 €
RV-R01001.11210-11700.00	11,21-11,70	35	64	100	11	6	208,05 €	201,37 €	194,64 €
RV-R01001.11710-11870.00	11,71-11,87	35	64	100	11	6	216,62 €	209,64 €	202,40 €
RV-R01001.11880-12600.00	11,88-12,60	35	64	100	12	6	225,14 €	217,89 €	210,64 €
RV-R01001.12610-12870.00	12,61-12,87	35	64	100	12	6	239,42 €	231,72 €	224,00 €
RV-R01001.12880-13870.00	12,88-13,87	35	64	100	13	6	239,42 €	231,72 €	224,00 €
RV-R01001.13880-14100.00	13,88-14,10	35	64	100	14	6	325,38 €	315,62 €	306,29 €
RV-R01001.14110-15100.00	14,11-15,10	35	64	100	14	6	347,08 €	338,42 €	330,24 €
RV-R01001.15110-15870.00	15,11-15,87	35	64	100	14	6	355,74 €	346,25 €	338,58 €
RV-R01001.15880-16100.00	15,88-16,10	35	64	100	16	6	355,74 €	346,20 €	337,11 €
RV-R01001.16110-17870.00	16,11-17,87	35	64	100	16	6	407,81 €	399,46 €	34,05 €
RV-R01001.17880-18100.00	17,88-18,10	35	64	100	18	6	407,81 €	399,40 €	391,49 €
RV-R01001.18110-19870.00	18,11-19,87	35	64	100	18	6	510,02 €	500,70 €	487,89 €
RV-R01001.19880-20100.00	19,88-20,10	35	64	100	20	6	510,02 €	500,70 €	487,89 €



RV-R01001

VHM-MASCHINENREIBAHLE DULO 1/100 RECHTSSCH./LINKSDRALL

MATERIALBESCHREIBUNG

		Vc m/min von/bis		f mm/U		f mm/U		f mm/U		f mm/U		f mm/U	
				Ø 0,1-2,99 von/bis	Ø 3,0-5,99 von/bis	Ø 6,0-9,99 von/bis	Ø 10,0-15,99 von/bis	Ø 16,0-20,0 von/bis					
P.1	<500N/mm	30	40	0,080	0,100	0,100	0,150	0,150	0,200	0,200	0,250	0,250	0,300
P.2	<650N/mm	25	35	0,080	0,100	0,100	0,150	0,150	0,200	0,200	0,250	0,250	0,300
P.3	<800N/mm	25	35	0,080	0,100	0,100	0,150	0,150	0,200	0,200	0,250	0,250	0,300
P.4	<1000N/mm	25	35	0,60	0,080	0,080	0,100	0,100	0,140	0,140	0,200	0,200	0,300
P.5	<1400N/mm	10	15	0,060	0,080	0,080	0,100	0,100	0,140	0,140	0,200	0,200	0,300
P.6	Einsatz-ST <1000N/mm	10	20	0,080	0,100	0,100	0,120	0,120	0,160	0,160	0,250	0,250	0,300
P.7	Nitrier-ST <1000N/mm	10	20	0,060	0,080	0,080	0,100	0,100	0,140	0,140	0,200	0,200	0,300
P.8	Vergütung-ST 850N/mm	15	20	0,060	0,080	0,080	0,100	0,100	0,140	0,140	0,200	0,200	0,300
P.9	Werkzeug-ST 1000N/mm	10	15	0,060	0,080	0,080	0,100	0,100	0,140	0,140	0,200	0,200	0,300
M.1	VA <750N/mm	10	15	0,060	0,080	0,080	0,100	0,100	0,140	0,140	0,200	0,200	0,300
M.2	VA >750N/mm	8	15	0,060	0,080	0,080	0,100	0,100	0,140	0,140	0,200	0,200	0,300
K.1	Gusseisen <200HB	2	20	0,120	0,180	0,180	0,200	0,200	0,230	0,230	0,300	0,300	0,350
K.2	Temperguss	10	15	0,100	0,120	0,120	0,160	0,160	0,180	0,180	0,250	0,250	0,300
K.3	Gusseisen mit Kugelgrafit												
N.1	AL <5%	30	60	0,120	0,180	0,180	0,200	0,200	0,230	0,230	0,300	0,300	0,350
N.2	AL <10%	20	40	0,120	0,180	0,180	0,200	0,200	0,230	0,230	0,300	0,300	0,350
N.3	AL >10%	15	30	0,120	0,180	0,180	0,200	0,200	0,230	0,230	0,300	0,300	0,350
N.4	Ms, Cu, Bronze, Rotguss	20	30	0,150	0,200	0,200	0,250	0,250	0,320	0,320	0,400	0,400	0,450
N.5	Duro-Thermoplast	15	30	0,080	0,100	0,100	0,150	0,150	0,200	0,200	0,250	0,250	0,300
N.6	Grafit, GFK	5	10	0,060	0,080	0,080	0,100	0,100	0,140	0,140	0,200	0,200	0,300
S.1	Titan												
S.2	Nickel												
H.1	45-52 HRC												
H.2	52-60 HRC												
H.3	60-65 HRC												

RV-R01002

VHM SACKLOCH-REIBAHLE, RECHTSSCH./RECHTSDRALL

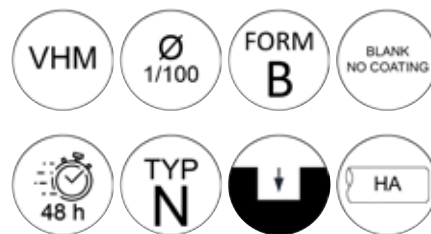

Artikel-Nr. Article-No.	Durchmesser	Schneidlänge	Nutzlänge	Gesamtlänge	Schaftdrn.	Zähnezahl	Preis/Euro Price/Euro
RV-R01002.01180-01480.00	1,18-1,48	12	23	40	1,5	4	65,55 €
RV-R01002.01490-01980.00	1,49-1,98	16	28	45	2	4	62,72 €
RV-R01002.01990-02070.00	1,99-2,07	18	31	50	2	4	62,72 €
RV-R01020.02080-02370.00	2,08-2,37	18	31	50	3	4	62,72 €
RV-R01002.02380-02670.00	2,38-2,67	20	34	55	3	4	62,72 €
RV-R01002.02680-02980.00	2,68-2,98	20	39	60	3	4	65,85 €
RV-R01002.02990-03070.00	2,99-3,07	20	39	60	3	6	65,85 €
RV-R01002.03080-03670.00	3,08-3,67	22	37	60	4	6	65,85 €
RV-R01002.03680-04070.00	3,68-4,07	24	40	65	4	6	68,97 €
RV-R01002.04080-04870.00	4,08-4,87	24	40	65	5	6	75,18 €
RV-R01002.04880-05200.00	4,88-5,20	26	48	75	5	6	84,66 €
RV-R01002.05210-05870.00	5,21-5,87	26	48	75	5	6	90,91 €
RV-R01002.05880-06170.00	5,88-6,17	26	48	75	6	6	100,31 €
RV-R01002.06180-06600.00	6,18-6,60	30	49	80	6	6	106,59 €
RV-R01002.06610-06870.00	6,61-6,87	30	49	80	6	6	112,88 €
RV-R01002.06880-07200.00	6,88-7,20	35	59	95	7	6	122,29 €
RV-R01002.07210-07870.00	7,21-7,87	35	59	95	7	6	137,94 €
RV-R01002.07880-08200.00	7,88-8,20	35	64	100	8	6	150,46 €
RV-R01002.08210-08700.00	8,21-8,70	35	64	100	8	6	166,19 €
RV-R01002.08710-08870.00	8,71-8,87	35	64	100	8	6	172,44 €
RV-R01002.08880-09200.00	8,88-9,20	35	64	100	9	6	175,56 €
RV-R01002.09210-09700.00	9,21-9,70	35	64	100	9	6	181,85 €
RV-R01002.09710-09870.00	9,71-9,87	35	64	100	9	6	194,38 €
RV-R01002.09880-10700.00	9,88-10,70	35	64	100	10	6	210,02 €
RV-R01002.10710-10870.00	10,71-10,87	35	64	100	10	6	216,36 €
RV-R01002.10880-11200.00	10,88-11,20	35	64	100	11	6	222,59 €
RV-R01002.11210-11700.00	11,21-11,70	35	64	100	11	6	228,89 €
RV-R01002.11710-11870.00	11,71-11,87	35	64	100	11	6	238,30 €
RV-R01002.11880-12600.00	11,88-12,60	35	64	100	12	6	247,66 €
RV-R01002.12610-12870.00	12,61-12,87	35	64	100	12	6	263,39 €
RV-R01002.12880-13870.00	12,88-13,87	35	64	100	13	6	263,39 €
RV-R01002.13880-14100.00	13,88-14,10	35	64	100	14	6	357,94 €
RV-R01002.14110-15100.00	14,11-15,10	35	64	100	14	6	381,78 €



RV-R01002

VHM SACKLOCH-REIBAHLE, RECHTSSCH./RECHTSDRALL

RV-R01002.15110-15870.00	15,11-15,87	35	64	100	14	6	391,31 €
RV-R01002.15880-16100.00	15,88-16,10	35	64	100	16	6	339,50 €
RV-R01002.16110-17870.00	16,11-17,87	35	64	100	16	6	448,61 €
RV-R01002.17880-18100.00	17,88-18,10	35	64	100	18	6	448,61 €
RV-R01002.18110-19870.00	18,11-19,87	35	64	100	18	6	561,06 €
RV-R01002.19880-2010000	19,88-20,10	35	64	100	20	6	486,77 €

AUFPREIS FÜR STIRNANSCHNITT

Artikel-Nr. Article-No.	Durchmesser	Preis/Euro ab 1-4 Stück	Preis/Euro ab 5 Stück
RV-RS1002.02950-06050.00	2,95-6,05	52,71 €	32,39 €
RV-RS1002.06060-18100.00	6,06-18,10	62,83 €	42,57 €

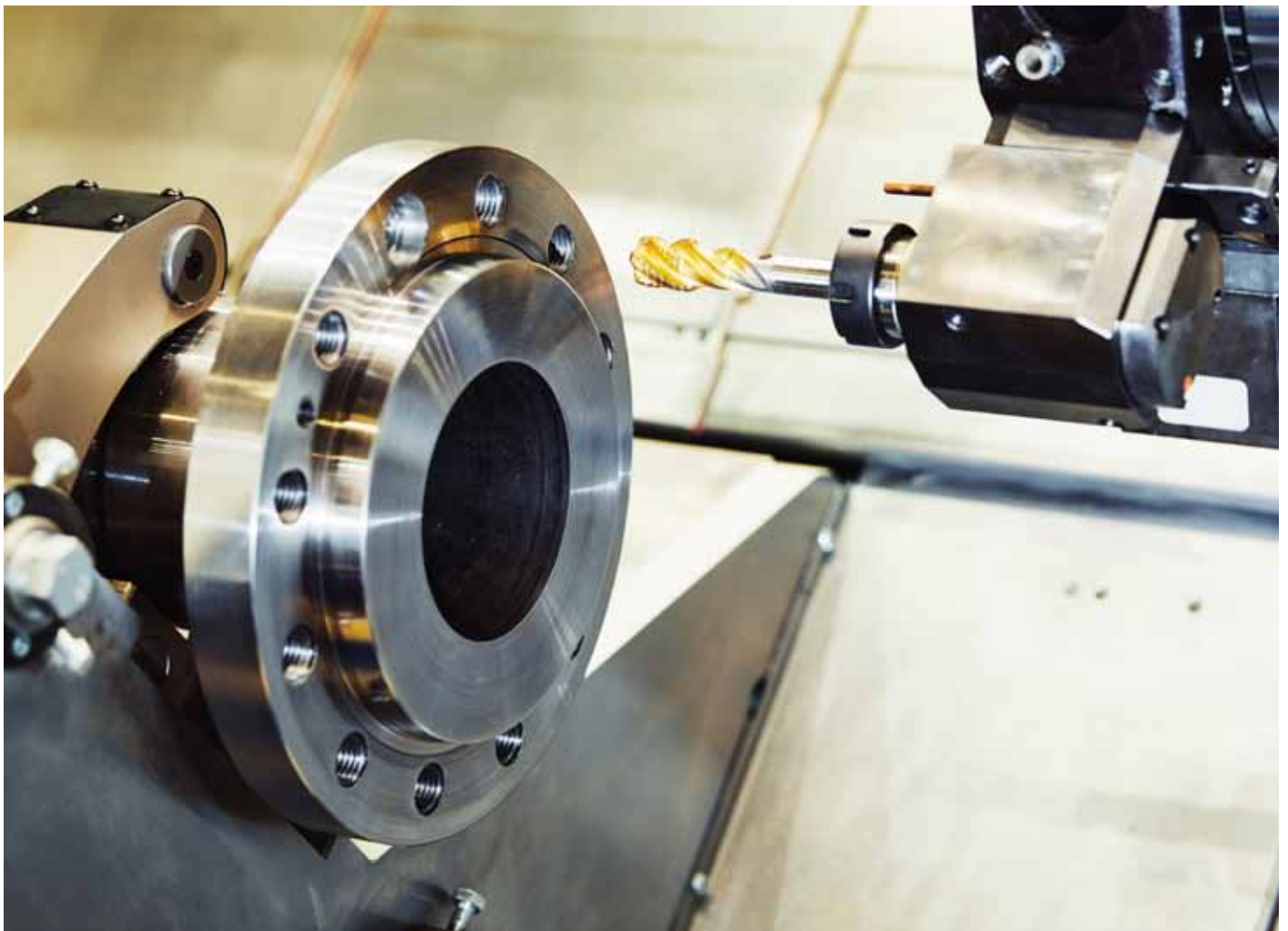



MATERIALBESCHREIBUNG

		Vc m/min von/bis		f mm/U		f mm/U		f mm/U		f mm/U		f mm/U	
				Ø 0,1-2,99 von/bis	Ø 3,0-5,99 von/bis	Ø 6,0-9,99 von/bis	Ø 10,0-15,99 von/bis	Ø 16,0-20,0 von/bis	Ø 10,0-15,99 von/bis	Ø 16,0-20,0 von/bis			
P.1	<500N/mm	30	40	0,080	0,100	0,100	0,150	0,150	0,200	0,200	0,250	0,250	0,300
P.2	<650N/mm	25	35	0,080	0,100	0,100	0,150	0,150	0,200	0,200	0,250	0,250	0,300
P.3	<800N/mm	25	35	0,080	0,100	0,100	0,150	0,150	0,200	0,200	0,250	0,250	0,300
P.4	<1000N/mm	25	35	0,60	0,080	0,080	0,100	0,100	0,140	0,140	0,200	0,200	0,300
P.5	<1400N/mm	10	15	0,060	0,080	0,080	0,100	0,100	0,140	0,140	0,200	0,200	0,300
P.6	Einsatz-ST <1000N/mm	10	20	0,080	0,100	0,100	0,120	0,120	0,160	0,160	0,250	0,250	0,300
P.7	Nitrier-ST <1000N/mm	10	20	0,060	0,080	0,080	0,100	0,100	0,140	0,140	0,200	0,200	0,300
P.8	Vergütung-ST 850N/mm	15	20	0,060	0,080	0,080	0,100	0,100	0,140	0,140	0,200	0,200	0,300
P.9	Werkzeug-ST 1000N/mm	10	15	0,060	0,080	0,080	0,100	0,100	0,140	0,140	0,200	0,200	0,300
M.1	VA <750N/mm	10	15	0,060	0,080	0,080	0,100	0,100	0,140	0,140	0,200	0,200	0,300
M.2	VA >750N/mm	8	15	0,060	0,080	0,080	0,100	0,100	0,140	0,140	0,200	0,200	0,300
K.1	Gusseisen <200HB	2	20	0,120	0,180	0,180	0,200	0,200	0,230	0,230	0,300	0,300	0,350
K.2	Temperguss	10	15	0,100	0,120	0,120	0,160	0,160	0,180	0,180	0,250	0,250	0,300
K.3	Gusseisen mit Kugelgrafit												
N.1	AL <5%	30	60	0,120	0,180	0,180	0,200	0,200	0,230	0,230	0,300	0,300	0,350
N.2	AL <10%	20	40	0,120	0,180	0,180	0,200	0,200	0,230	0,230	0,300	0,300	0,350
N.3	AL >10%	15	30	0,120	0,180	0,180	0,200	0,200	0,230	0,230	0,300	0,300	0,350
N.4	Ms, Cu, Bronze, Rotguss	20	30	0,150	0,200	0,200	0,250	0,250	0,320	0,320	0,400	0,400	0,450
N.5	Duro-Thermoplast	15	30	0,080	0,100	0,100	0,150	0,150	0,200	0,200	0,250	0,250	0,300
N.6	Grafit, GFK	5	10	0,060	0,080	0,080	0,100	0,100	0,140	0,140	0,200	0,200	0,300
S.1	Titan												
S.2	Nickel												
H.1	45-52 HRC												
H.2	52-60 HRC												
H.3	60-65 HRC												



RV-R12001

VHM SACKLOCH-REIBAHLE, RECHTSSCHNEIDEND MIT ZENTRALER IK

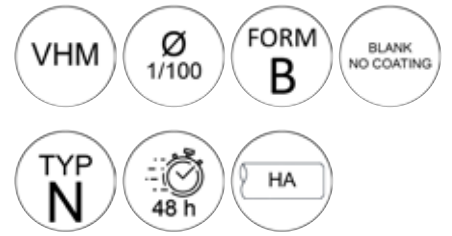

Artikel-Nr. Article-No.	Durchmesser	Schneidlänge	Nutzlänge	Gesamtlänge	Schaftdrn.	Zähnezahl	Preis/Euro Price/Euro
RV-R12001.02950-03050.00	2,95-3,05	22	40	75	6	6	160,95 €
RV-R12001.03060-03960.00	3,06-3,96	24	40	75	6	6	172,46 €
RV-R12001.03970-04050.00	3,97-4,05	24	40	75	6	6	142,51 €
RV-R12001.04060-04960.00	4,06-4,96	24	40	75	6	6	149,41 €
RV-R12001.04970-05050.00	4,97-5,05	24	40	75	6	6	133,32 €
RV-R12001.05060-05960.00	5,06-5,96	24	40	75	6	6	140,21 €
RV-R12001.05970-06050.00	5,97-6,05	30	45	80	6	6	126,43 €
RV-R12001.06060-06250.00	6,06-6,25	30	45	80	6	6	179,32 €
RV-R12001.06260-06960.00	6,26-6,96	30	63	103	8	6	179,32 €
RV-R12001.06970-07050.00	6,97-7,05	30	63	103	8	6	172,46 €
RV-R12001.07060-07960.00	7,06-7,96	30	63	103	8	6	179,32 €
RV-R12001.07970-08050.00	7,97-8,05	35	63	103	8	6	172,44 €
RV-R12001.08060-08250.00	8,06-8,25	35	63	103	8	6	206,95 €
RV-R12001.08260-08960.00	8,26-8,96	35	63	103	10	6	206,95 €
RV-R12001.08970-09050.00	8,97-9,05	35	63	103	10	6	206,95 €
RV-R12001.09060-09960.00	9,06-9,96	35	63	103	10	6	206,95 €
RV-R12001.09970-10050.00	9,97-10,05	35	63	103	10	6	195,41 €
RV-R12001.10060-10250.00	10,06-10,25	35	63	103	10	6	275,88 €
RV-R12001.10260-10960.00	10,26-10,96	40	63	103	12	6	275,88 €
RV-R12001.10970-11050.00	10,97-11,05	40	63	103	12	6	275,88 €
RV-R12001.11060-11960.00	11,06-11,96	40	63	103	12	6	275,88 €
RV-R12001.11970-12250.00	11,97-12,25	40	63	103	12	6	275,88 €
RV-R12001.12260-12650.00	12,26-12,65	40	63	103	14	6	307,71 €
RV-R12001.12660-13250.00	12,66-13,25	40	63	103	14	6	325,38 €
RV-R12001.13260-14250.00	13,26-14,25	40	63	103	14	6	383,37 €
RV-R12001.14260-16250.00	14,26-16,25	40	63	103	16	6	446,00 €



MATERIALBESCHREIBUNG

		Vc m/min von/bis		f mm/U		f mm/U		f mm/U		f mm/U		f mm/U	
				Ø 0,1-2,99 von/bis	Ø 3,0-5,99 von/bis	Ø 6,0-9,99 von/bis	Ø 10,0-15,99 von/bis	Ø 16,0-20,0 von/bis					
P.1	<500N/mm	30	40	0,080	0,100	0,100	0,150	0,150	0,200	0,200	0,250	0,250	0,300
P.2	<650N/mm	25	35	0,080	0,100	0,100	0,150	0,150	0,200	0,200	0,250	0,250	0,300
P.3	<800N/mm	25	35	0,080	0,100	0,100	0,150	0,150	0,200	0,200	0,250	0,250	0,300
P.4	<1000N/mm	25	35	0,60	0,080	0,080	0,100	0,100	0,140	0,140	0,200	0,200	0,300
P.5	<1400N/mm	10	15	0,060	0,080	0,080	0,100	0,100	0,140	0,140	0,200	0,200	0,300
P.6	Einsatz-ST <1000N/mm	10	20	0,080	0,100	0,100	0,120	0,120	0,160	0,160	0,250	0,250	0,300
P.7	Nitrier-ST <1000N/mm	10	20	0,060	0,080	0,080	0,100	0,100	0,140	0,140	0,200	0,200	0,300
P.8	Vergütung-ST 850N/mm	15	20	0,060	0,080	0,080	0,100	0,100	0,140	0,140	0,200	0,200	0,300
P.9	Werkzeug-ST 1000N/mm	10	15	0,060	0,080	0,080	0,100	0,100	0,140	0,140	0,200	0,200	0,300
M.1	VA <750N/mm	10	15	0,060	0,080	0,080	0,100	0,100	0,140	0,140	0,200	0,200	0,300
M.2	VA >750N/mm	8	15	0,060	0,080	0,080	0,100	0,100	0,140	0,140	0,200	0,200	0,300
K.1	Gusseisen <200HB	2	20	0,120	0,180	0,180	0,200	0,200	0,230	0,230	0,300	0,300	0,350
K.2	Temperguss	10	15	0,100	0,120	0,120	0,160	0,160	0,180	0,180	0,250	0,250	0,300
K.3	Gusseisen mit Kugelgrafit												
N.1	AL <5%	30	60	0,120	0,180	0,180	0,200	0,200	0,230	0,230	0,300	0,300	0,350
N.2	AL <10%	20	40	0,120	0,180	0,180	0,200	0,200	0,230	0,230	0,300	0,300	0,350
N.3	AL >10%	15	30	0,120	0,180	0,180	0,200	0,200	0,230	0,230	0,300	0,300	0,350
N.4	Ms, Cu, Bronze, Rotguss	20	30	0,150	0,200	0,200	0,250	0,250	0,320	0,320	0,400	0,400	0,450
N.5	Duro-Thermoplast	15	30	0,080	0,100	0,100	0,150	0,150	0,200	0,200	0,250	0,250	0,300
N.6	Grafit, GFK	5	10	0,060	0,080	0,080	0,100	0,100	0,140	0,140	0,200	0,200	0,300
S.1	Titan												
S.2	Nickel												
H.1	45-52 HRC												
H.2	52-60 HRC												
H.3	60-65 HRC												



RV-R11001

VHM SACKLOCH-REIBAHLE, RECHTSSCHNEIDEND MIT SEITLICHER IK

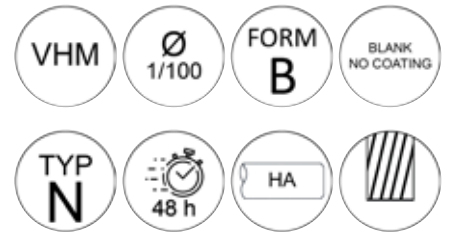

Artikel-Nr. Article-No.	Durchmesser	Schneidlänge	Nutzlänge	Gesamtlänge	Schaftdrn.	Zähnezahl	Preis/Euro Price/Euro
RV-R11001.02990-03100.00	2,90-3,10	14	45	75	6	4	342,61 €
RV-R11001.03900-04100.00	3,90-4,10	14	45	75	6	4	342,61 €
RV-R11001.04900-05100.00	4,90-5,10	14	55	85	6	4	342,61 €
RV-R11001.05900-06100.00	5,90-6,10	14	55	85	6	4	342,61 €
RV-R11001.06900-07100.00	6,90-7,10	18	70	105	8	4	458,17 €
RV-R11001.07900-08100.00	7,90-8,10	18	70	105	8	4	458,17 €
RV-R11001.08900-09100.00	8,90-9,10	22	75	115	10	6	529,11 €
RV-R11001.09900-10100.00	9,90-10,10	22	75	115	10	6	529,11 €
RV-R11001.10900-11100.00	10,90-11,10	22	75	115	12	6	573,72 €
RV-R11001.11900-12100.00	11,90-12,10	22	75	115	12	6	573,72 €
RV-R11001.12900-13100.00	12,90-13,10	24	75	115	14	6	786,59 €
RV-R11001.13900-14100.00	13,90-14,10	24	75	115	14	6	786,59 €



MATERIALBESCHREIBUNG

		Vc m/min von/bis		f mm/U		f mm/U		f mm/U		f mm/U		f mm/U	
				Ø 0,1-2,99 von/bis	Ø 3,0-5,99 von/bis	Ø 6,0-9,99 von/bis	Ø 10,0-15,99 von/bis	Ø 16,0-20,0 von/bis					
P.1	<500N/mm	30	40	0,080	0,100	0,100	0,150	0,150	0,200	0,200	0,250	0,250	0,300
P.2	<650N/mm	25	35	0,080	0,100	0,100	0,150	0,150	0,200	0,200	0,250	0,250	0,300
P.3	<800N/mm	25	35	0,080	0,100	0,100	0,150	0,150	0,200	0,200	0,250	0,250	0,300
P.4	<1000N/mm	25	35	0,60	0,080	0,080	0,100	0,100	0,140	0,140	0,200	0,200	0,300
P.5	<1400N/mm	10	15	0,060	0,080	0,080	0,100	0,100	0,140	0,140	0,200	0,200	0,300
P.6	Einsatz-ST <1000N/mm	10	20	0,080	0,100	0,100	0,120	0,120	0,160	0,160	0,250	0,250	0,300
P.7	Nitrier-ST <1000N/mm	10	20	0,060	0,080	0,080	0,100	0,100	0,140	0,140	0,200	0,200	0,300
P.8	Vergütung-ST 850N/mm	15	20	0,060	0,080	0,080	0,100	0,100	0,140	0,140	0,200	0,200	0,300
P.9	Werkzeug-ST 1000N/mm	10	15	0,060	0,080	0,080	0,100	0,100	0,140	0,140	0,200	0,200	0,300
M.1	VA <750N/mm	10	15	0,060	0,080	0,080	0,100	0,100	0,140	0,140	0,200	0,200	0,300
M.2	VA >750N/mm	8	15	0,060	0,080	0,080	0,100	0,100	0,140	0,140	0,200	0,200	0,300
K.1	Gusseisen <200HB	2	20	0,120	0,180	0,180	0,200	0,200	0,230	0,230	0,300	0,300	0,350
K.2	Temperguss	10	15	0,100	0,120	0,120	0,160	0,160	0,180	0,180	0,250	0,250	0,300
K.3	Gusseisen mit Kugelgrafit												
N.1	AL <5%	30	60	0,120	0,180	0,180	0,200	0,200	0,230	0,230	0,300	0,300	0,350
N.2	AL <10%	20	40	0,120	0,180	0,180	0,200	0,200	0,230	0,230	0,300	0,300	0,350
N.3	AL >10%	15	30	0,120	0,180	0,180	0,200	0,200	0,230	0,230	0,300	0,300	0,350
N.4	Ms, Cu, Bronze, Rotguss	20	30	0,150	0,200	0,200	0,250	0,250	0,320	0,320	0,400	0,400	0,450
N.5	Duro-Thermoplast	15	30	0,080	0,100	0,100	0,150	0,150	0,200	0,200	0,250	0,250	0,300
N.6	Grafit, GFK	5	10	0,060	0,080	0,080	0,100	0,100	0,140	0,140	0,200	0,200	0,300
S.1	Titan												
S.2	Nickel												
H.1	45-52 HRC												
H.2	52-60 HRC												
H.3	60-65 HRC												



RV-R01003

VHM-REIBAHLE H7 RECHTSSCH./LINKSDRALL

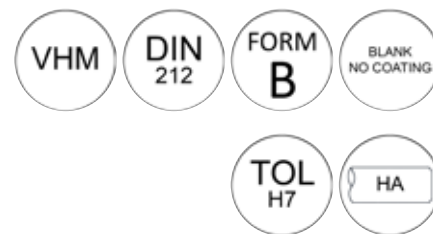

Artikel-Nr. Article-No.	D1	D2	L2	L3	L1	Zähnezahl	Preis/Euro Price/Euro
RV-R01003.01000.H7	1,0	1,0	7	22	38	4	27,90 €
RV-R01003.01100.H7	1,1	1,1	10	24	40	4	49,01 €
RV-R01003.01200.H7	1,2	1,2	10	24	40	4	49,01 €
RV-R01003.01300.H7	1,3	1,3	10	24	40	4	49,01 €
RV-R01003.01400.H7	1,4	1,4	10	24	40	4	49,01 €
RV-R01003.01500.H7	1,5	1,5	10	24	40	4	27,90 €
RV-R01003.01600.H7	1,6	1,6	11	25	43	4	49,35 €
RV-R01003.01700.H7	1,7	1,7	11	25	43	4	49,35 €
RV-R01003.01800.H7	1,8	1,8	12	31	49	4	49,35 €
RV-R01003.01900.H7	1,9	1,9	12	31	49	4	49,35 €
RV-R01003.02000.H7	2,0	2,0	12	31	49	4	26,70 €
RV-R01003.02100.H7	2,1	2,1	12	31	49	4	49,35 €
RV-R01003.02200.H7	2,2	2,2	12	31	49	4	49,35 €
RV-R01003.02300.H7	2,3	2,3	12	31	49	4	49,35 €
RV-R01003.02400.H7	2,4	2,4	18	38	57	6	49,35 €
RV-R01003.02500.H7	2,5	2,5	18	38	57	6	31,28 €
RV-R01003.02600.H7	2,6	2,6	18	38	57	6	49,53 €
RV-R01003.02700.H7	2,7	2,7	18	38	57	6	49,53 €
RV-R01003.02800.H7	2,8	2,8	18	38	57	6	49,53 €
RV-R01003.02900.H7	2,9	2,9	18	38	57	6	49,53 €
RV-R01003.03000.H7	3,0	3,0	18	38	57	6	33,46 €
RV-R01003.03100.H7	3,1	3,1	18	38	57	6	49,53 €
RV-R01003.03200.H7	3,2	3,2	18	38	57	6	49,53 €
RV-R01003.03300.H7	3,3	3,3	18	38	57	6	49,53 €
RV-R01003.03400.H7	3,4	3,4	18	38	57	6	51,38 €
RV-R01003.03500.H7	3,5	3,5	18	38	57	6	35,67 €
RV-R01003.03600.H7	3,6	3,6	18	38	57	6	51,71 €
RV-R01003.03700.H7	3,7	3,7	18	38	57	6	51,71 €
RV-R01003.03800.H7	3,8	4,0	19	51	75	6	68,28 €
RV-R01003.03900.H7	3,9	4,0	19	51	75	6	68,28 €
RV-R01003.04000.H7	4,0	4,0	19	51	75	6	44,46 €
RV-R01003.04100.H7	4,1	4,0	19	51	75	6	68,28 €
RV-R01003.04200.H7	4,2	4,0	19	51	75	6	68,28 €



RV-R01003 VHM-REIBAHLE H7 RECHTSSCH./LINKSDRALL

RV-R01003.04300.H7	4,3	4,5	21	55	80	6	68,28 €
RV-R01003.04400.H7	4,4	4,5	21	55	80	6	68,28 €
RV-R01003.04500.H7	4,5	4,5	21	55	80	6	49,01 €
RV-R01003.04600.H7	4,6	4,5	21	55	80	6	71,32 €
RV-R01003.04700.H7	4,7	4,5	21	55	80	6	71,32 €
RV-R01003.04800.H7	4,8	5,0	23	60	86	6	74,70 €
RV-R01003.04900.H7	4,9	5,0	23	60	86	6	74,70 €
RV-R01003.05000.H7	5,0	5,0	23	60	86	6	53,40 €
RV-R01003.05100.H7	5,1	5,0	23	60	86	6	74,70 €
RV-R01003.05200.H7	5,2	5,0	23	60	86	6	74,70 €
RV-R01003.05300.H7	5,3	5,0	23	60	86	6	74,70 €
RV-R01003.05400.H7	5,4	5,5	26	66	93	6	88,74 €
RV-R01003.05500.H7	5,5	5,5	26	66	93	6	62,37 €
RV-R01003.05600.H7	5,6	5,5	26	66	93	6	88,74 €
RV-R01003.05700.H7	5,7	5,5	26	66	93	6	88,74 €
RV-R01003.05800.H7	5,8	5,5	26	66	93	6	88,74 €
RV-R01003.05900.H7	5,9	6,0	28	73	101	6	92,27 €
RV-R01003.06000.H7	6,0	6,0	28	73	101	6	71,32 €
RV-R01003.06500.H7	6,5	6,0	28	73	101	6	89,23 €
RV-R01003.07000.H7	7,0	7,0	31	80	109	6	100,23 €
RV-R01003.07500.H7	7,5	7,0	31	80	109	6	102,60 €
RV-R01003.08000.H7	8,0	8,0	33	86	117	6	102,60 €
RV-R01003.08500.H7	8,5	8,0	33	86	117	6	127,09 €
RV-R01003.09000.H7	9,0	9,0	36	91	125	6	127,09 €
RV-R01003.09500.H7	9,5	9,0	36	91	125	6	135,88 €
RV-R01003.10000.H7	10,0	10,0	38	99	133	6	135,88 €
RV-R01003.10500.H7	10,5	10,0	38	99	133	6	162,76 €
RV-R01003.11000.H7	11,0	10,0	38	99	133	6	162,76 €
RV-R01003.11500.H7	11,5	12,0	44	106	151	6	182,70 €
RV-R01003.12000.H7	12,0	12,0	44	106	151	6	182,70 €



RV-R01003

VHM-REIBAHLE H7 RECHTSSCH./LINKSDRALL

MATERIALBESCHREIBUNG

		Vc m/min von/bis		f mm/U		f mm/U		f mm/U		f mm/U		f mm/U	
				Ø 0,1-2,99 von/bis	Ø 3,0-5,99 von/bis	Ø 6,0-9,99 von/bis	Ø 10,0-15,99 von/bis	Ø 16,0-20,0 von/bis	Ø 10,0-15,99 von/bis	Ø 16,0-20,0 von/bis			
P.1	<500N/mm	30	40	0,080	0,100	0,100	0,150	0,150	0,200	0,200	0,250	0,250	0,300
P.2	<650N/mm	25	35	0,080	0,100	0,100	0,150	0,150	0,200	0,200	0,250	0,250	0,300
P.3	<800N/mm	25	35	0,080	0,100	0,100	0,150	0,150	0,200	0,200	0,250	0,250	0,300
P.4	<1000N/mm	25	35	0,60	0,080	0,080	0,100	0,100	0,140	0,140	0,200	0,200	0,300
P.5	<1400N/mm	10	15	0,060	0,080	0,080	0,100	0,100	0,140	0,140	0,200	0,200	0,300
P.6	Einsatz-ST <1000N/mm	10	20	0,080	0,100	0,100	0,120	0,120	0,160	0,160	0,250	0,250	0,300
P.7	Nitrier-ST <1000N/mm	10	20	0,060	0,080	0,080	0,100	0,100	0,140	0,140	0,200	0,200	0,300
P.8	Vergütung-ST 850N/mm	15	20	0,060	0,080	0,080	0,100	0,100	0,140	0,140	0,200	0,200	0,300
P.9	Werkzeug-ST 1000N/mm	10	15	0,060	0,080	0,080	0,100	0,100	0,140	0,140	0,200	0,200	0,300
M.1	VA <750N/mm	10	15	0,060	0,080	0,080	0,100	0,100	0,140	0,140	0,200	0,200	0,300
M.2	VA >750N/mm	8	15	0,060	0,080	0,080	0,100	0,100	0,140	0,140	0,200	0,200	0,300
K.1	Gusseisen <200HB	2	20	0,120	0,180	0,180	0,200	0,200	0,230	0,230	0,300	0,300	0,350
K.2	Temperguss	10	15	0,100	0,120	0,120	0,160	0,160	0,180	0,180	0,250	0,250	0,300
K.3	Gusseisen mit Kugelgrafit												
N.1	AL <5%	30	60	0,120	0,180	0,180	0,200	0,200	0,230	0,230	0,300	0,300	0,350
N.2	AL <10%	20	40	0,120	0,180	0,180	0,200	0,200	0,230	0,230	0,300	0,300	0,350
N.3	AL >10%	15	30	0,120	0,180	0,180	0,200	0,200	0,230	0,230	0,300	0,300	0,350
N.4	Ms, Cu, Bronze, Rotguss	20	30	0,150	0,200	0,200	0,250	0,250	0,320	0,320	0,400	0,400	0,450
N.5	Duro-Thermoplast	15	30	0,080	0,100	0,100	0,150	0,150	0,200	0,200	0,250	0,250	0,300
N.6	Grafit, GFK	5	10	0,060	0,080	0,080	0,100	0,100	0,140	0,140	0,200	0,200	0,300
S.1	Titan												
S.2	Nickel												
H.1	45-52 HRC												
H.2	52-60 HRC												
H.3	60-65 HRC												

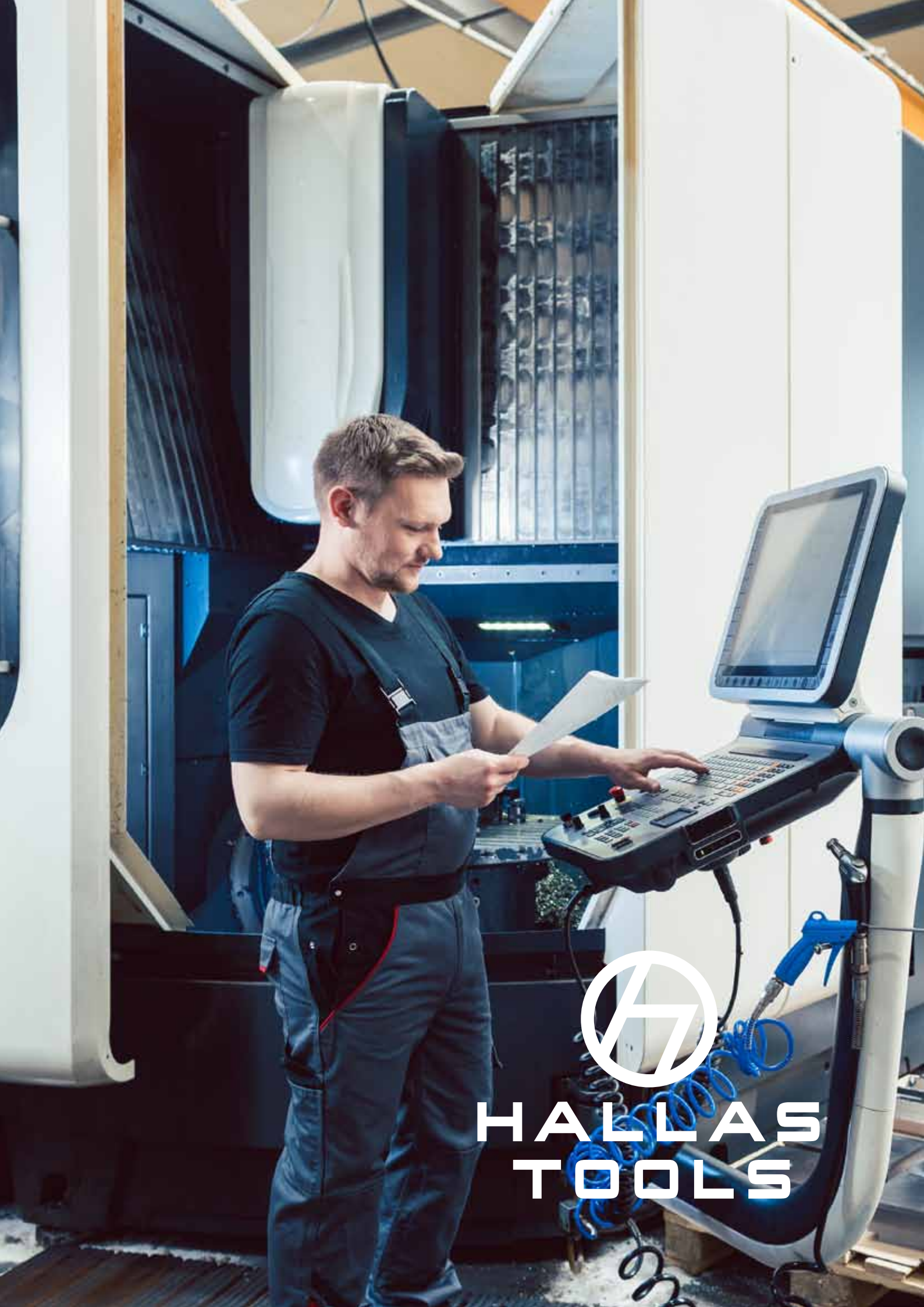

HALLAS
TOOLS



Sonderwerkzeuge
im **Fräs-** und **Bohrbereich**
auch als Express-Service
innerhalb von

5-8 ARBEITSTAGEN

inklusive Beschichtung
lieferbar!

VHM-Reibahlen in
unseren Werksausführungen
mit 2 Stellen nach
dem Komma
(z.Bsp. 7,58mm),
als Passungsreibahlen
(z. Bsp. 8H11) oder
Reibahlen mit einer
eingeschränkten Toleranz
(z. Bsp. 12,089 +0,002/+0,006)
können wir innerhalb von

48 STUNDEN

liefern!





RH-RA005

HSSE-AUTOMATENREIBAHLE DIN 8089 TOL H7

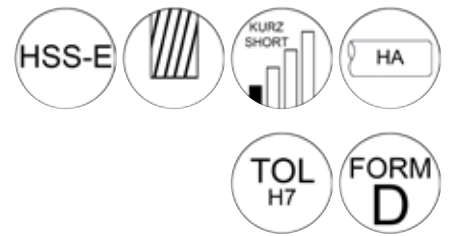

Artikel-Nr. Article-No.	D1	D2	SL	GL	Zähnezahl	Preis/Euro Price/Euro
RH-RA005.0150U.H7	1,5	1,5	12	45	4	26,31 €
RH-RA005.0200U.H7	2	2	16	50	4	24,28 €
RH-RA005.0250U.H7	2,5	2,5	18	56	4	24,28 €
RH-RA005.0300U.H7	3	3	18	56	6	24,28 €
RH-RA005.0350U.H7	3,5	3	20	56	6	25,32 €
RH-RA005.0400U.H7	4	4	20	56	6	23,76 €
RH-RA005.0450U.H7	4,5	4	22	63	6	26,57 €
RH-RA005.0500U.H7	5	4	22	63	6	25,32 €
RH-RA005.0550U.H7	5,5	5	22	63	6	30,16 €
RH-RA005.0600U.H7	6	5	22	63	6	25,32 €
RH-RA005.0650U.H7	6,5	5	22	63	6	31,10 €
RH-RA005.0700U.H7	7	6,3	25	71	6	31,10 €
RH-RA005.0750U.H7	7,5	6,3	25	71	6	36,56 €
RH-RA005.0800U.H7	8	6,3	25	71	6	31,16 €
RH-RA005.0850U.H7	8,5	6,3	25	71	6	39,42 €
RH-RA005.0900U.H7	9	8	25	71	6	37,34 €
RH-RA005.0950U.H7	9,5	8	25	71	6	41,55 €
RH-RA005.1000U.H7	10	8	25	71	6	37,60 €
RH-RA005.1100U.H7	11	10	28	80	6	52,26 €
RH-RA005.1200U.H7	12	10	28	80	6	54,70 €
RH-RA005.1300U.H7	13	10	28	80	6	61,93 €
RH-RA005.1400U.H7	14	12,5	32	90	8	62,76 €
RH-RA005.1500U.H7	15	12,5	32	90	8	63,75 €
RH-RA005.1600U.H7	16	12,5	32	90	8	67,08 €
RH-RA005.1700U.H7	17	12,5	32	90	8	72,75 €
RH-RA005.1800U.H7	18	16	36	100	8	82,78 €
RH-RA005.1900U.H7	19	16	36	100	8	93,60 €
RH-RA005.2000U.H7	20	16	36	100	8	89,86 €



RH-RA005

HSSE-AUTOMATENREIBAHLE DIN 8089 TOL H7

MATERIALBESCHREIBUNG

		Vc m/min von/bis		f mm/U		f mm/U		f mm/U		f mm/U		f mm/U		f mm/U		f mm/U	
				Ø 0,5-4,99 von/bis	Ø 5,0-7,99 von/bis	Ø 8,0-11,99 von/bis	Ø 12,0-19,99 von/bis	Ø 20,0-29,9 von/bis	Ø 30,0-39,9 von/bis	Ø 40,0-60,0 von/bis							
P.1	<500N/mm	10	12	0,080	0,100	0,100	0,120	0,120	0,160	0,160	0,250	0,250	0,300	0,300	0,360	0,360	0,450
P.2	<650N/mm	8	10	0,080	0,100	0,100	0,120	0,120	0,160	0,160	0,250	0,250	0,300	0,300	0,360	0,360	0,450
P.3	<800N/mm	6	10	0,080	0,100	0,100	0,120	0,120	0,160	0,160	0,250	0,250	0,300	0,300	0,360	0,360	0,450
P.4	<1000N/mm	4	6	0,060	0,080	0,080	0,100	0,100	0,140	0,140	0,200	0,200	0,300	0,300	0,350	0,350	0,450
P.5	<1400N/mm	3	5	0,60	0,080	0,080	0,100	0,100	0,140	0,140	0,200	0,200	0,300	0,300	0,350	0,350	0,450
P.6	Einsatz-ST <1000N/mm	4	6	0,080	0,100	0,100	0,120	0,120	0,160	0,160	0,250	0,250	0,300	0,300	0,360	0,360	0,450
P.7	Nitrier-ST <1000N/mm	4	6	0,060	0,080	0,080	0,100	0,100	0,140	0,140	0,200	0,200	0,300	0,300	0,350	0,350	0,450
P.8	Vergütung-ST 850N/mm	3	5	0,060	0,080	0,080	0,100	0,100	0,140	0,140	0,200	0,200	0,300	0,300	0,350	0,350	0,450
P.9	Werkzeug-ST 1000N/mm	4	8	0,060	0,080	0,080	0,100	0,100	0,140	0,140	0,200	0,200	0,300	0,300	0,350	0,350	0,450
M.1	VA <750N/mm	6	8	0,060	0,080	0,080	0,100	0,100	0,140	0,140	0,200	0,200	0,300	0,300	0,350	0,350	0,450
M.2	VA >750N/mm	4	6	0,060	0,080	0,080	0,100	0,100	0,140	0,140	0,200	0,200	0,300	0,300	0,350	0,350	0,450
K.1	Gusseisen <200HB	8	12	0,120	0,180	0,180	0,200	0,200	0,230	0,230	0,300	0,300	0,350	0,350	0,400	0,400	0,500
K.2	Temperguss	4	8	0,100	0,120	0,120	0,160	0,160	0,180	0,180	0,250	0,250	0,300	0,300	0,350	0,350	0,500
K.3	Gusseisen mit Kugelgrafit																
N.1	AL <5%	15	20	0,120	0,180	0,180	0,200	0,200	0,230	0,230	0,300	0,300	0,350	0,350	0,400	0,400	0,650
N.2	AL <10%	10	15	0,120	0,180	0,180	0,200	0,200	0,230	0,230	0,300	0,300	0,350	0,350	0,400	0,400	0,650
N.3	AL >10%																
N.4	Ms, Cu, Bronze, Rotguss	10	15	0,150	0,200	0,200	0,250	0,250	0,320	0,320	0,400	0,400	0,450	0,450	0,500	0,500	0,650
N.5	Duro-Thermoplast																
N.6	Grafit, GFK																
S.1	Titan	4	6	0,060	0,080	0,080	0,100	0,100	0,140	0,140	0,200	0,200	0,300	0,300	0,350	0,350	0,450
S.2	Nickel																
H.1	45-52 HRC																
H.2	52-60 HRC																
H.3	60-65 HRC																

REIBAHLEN



RH-R01006

HSSE-REIBAHLE 1/100 RECHTSSCH./LINKSDRALL



Artikel-Nr. Article-No.	D1	D2	SL	NL	GL	Zähnezahl	Preis/Euro Price/Euro
RH-R01006.0090U-0106U.01	0,90-1,06*	1,0	5,5	15,0	34,0	3	29,53 €
RH-R01006.0107U-0118U.01	1,07-1,18*	1,1	6,5	15,5	36,0	3	29,53 €
RH-R01006.0119U-0132U.01	1,19-1,32*	1,2	8,0	16,5	38,0	3	29,53 €
RH-R01006.0133U-0150U.01	1,33-1,50	1,5	8,0	18,0	40,0	3	29,53 €
RH-R01006.0151U-0170U.01	1,51-1,70	1,6	9,0	20,0	43,0	3	25,57 €
RH-R01006.0171U-0190U.01	1,71-1,90	1,8	10,0	22,0	46,0	4	25,57 €
RH-R01006.0191U-0212U.01	1,91-2,12	2,0	11,0	24,0	49,0	4	26,16 €
RH-R01006.0213U-0236U.01	2,13-2,36	2,2	12,0	25,0	53,0	4	26,16 €
RH-R01006.0237U-0265U.01	2,37-2,65	2,5	14,0	29,0	57,0	4	27,21 €
RH-R01006.0266U-0279U.01	2,66-2,79	2,8	15,0	33,0	61,0	4	27,21 €
RH-R01006.0280U-0289U.01	2,80-2,89	2,8	15,0	33,0	61,0	6	27,21 €
RH-R01006.0290U-0300U.01	2,90-3,00	3,0	15,0	33,0	61,0	6	27,21 €
RH-R01006.0301U-0335U.01	3,01-3,35	3,2	16,0	37,0	65,0	6	25,66 €
RH-R01006.0336U-0375U.01	3,36-3,75	3,5	18,0	42,0	70,0	6	28,53 €
RH-R01006.0376U-0425U.01	3,76-4,25	4,0	19,0	47,0	75,0	6	28,53 €
RH-R01006.0426U-0475U.01	4,26-4,75	4,5	21,0	52,0	80,0	6	24,43 €
RH-R01006.0476U-0530U.01	4,76-5,30	5,0	23,0	58,0	86,0	6	21,79 €
RH-R01006.0531U-0600U.01	5,31-6,00	5,6	26,0	57,0	93,0	6	23,02 €
RH-R01006.0601U-0670U.01	6,01-6,70	6,0	28,0	65,0	101,0	6	25,71 €
RH-R01006.0671U-0750U.01	6,71-7,50	7,1	31,0	73,0	109,0	6	25,71 €
RH-R01006.0751U-0850U.01	7,51-8,50	8,0	33,0	81,0	117,0	6	31,49 €
RH-R01006.0851U-0950U.01	8,51-9,50	9,0	36,0	85,0	125,0	6	31,49 €
RH-R01006.0951U-1060U.01	9,51-10,60	10,0	38,0	93,0	133,0	6	40,04 €
RH-R01006.1061U-1180U.01	10,61-11,80	10,0	41,0	102,0	142,0	6	47,00 €
RH-R01006.1181U-1225U.01	11,81-12,25	10,0	44,0	111,0	151,0	6	53,19 €
RH-R01006.1226U-1320U.01	12,26-13,20	10,0	44,0	111,0	151,0	8	53,19 €

* Werksnorm



MATERIALBESCHREIBUNG

		Vc m/min von/bis		f mm/U		f mm/U		f mm/U		f mm/U		f mm/U		f mm/U		f mm/U	
				Ø 0,5-4,99 von/bis	Ø 5,0-7,99 von/bis	Ø 8,0-11,99 von/bis	Ø 12,0-19,99 von/bis	Ø 20,0-29,9 von/bis	Ø 30,0-39,9 von/bis	Ø 40,0-60,0 von/bis							
P.1	<500N/mm	10	12	0,080	0,100	0,100	0,120	0,120	0,160	0,160	0,250	0,250	0,300	0,300	0,360	0,360	0,450
P.2	<650N/mm	8	10	0,080	0,100	0,100	0,120	0,120	0,160	0,160	0,250	0,250	0,300	0,300	0,360	0,360	0,450
P.3	<800N/mm	6	10	0,080	0,100	0,100	0,120	0,120	0,160	0,160	0,250	0,250	0,300	0,300	0,360	0,360	0,450
P.4	<1000N/mm	4	6	0,060	0,080	0,080	0,100	0,100	0,140	0,140	0,200	0,200	0,300	0,300	0,350	0,350	0,450
P.5	<1400N/mm	3	5	0,60	0,080	0,080	0,100	0,100	0,140	0,140	0,200	0,200	0,300	0,300	0,350	0,350	0,450
P.6	Einsatz-ST <1000N/mm	4	6	0,080	0,100	0,100	0,120	0,120	0,160	0,160	0,250	0,250	0,300	0,300	0,360	0,360	0,450
P.7	Nitrier-ST <1000N/mm	4	6	0,060	0,080	0,080	0,100	0,100	0,140	0,140	0,200	0,200	0,300	0,300	0,350	0,350	0,450
P.8	Vergütung-ST 850N/mm	3	5	0,060	0,080	0,080	0,100	0,100	0,140	0,140	0,200	0,200	0,300	0,300	0,350	0,350	0,450
P.9	Werkzeug-ST 1000N/mm	4	8	0,060	0,080	0,080	0,100	0,100	0,140	0,140	0,200	0,200	0,300	0,300	0,350	0,350	0,450
M.1	VA <750N/mm	6	8	0,060	0,080	0,080	0,100	0,100	0,140	0,140	0,200	0,200	0,300	0,300	0,350	0,350	0,450
M.2	VA >750N/mm	4	6	0,060	0,080	0,080	0,100	0,100	0,140	0,140	0,200	0,200	0,300	0,300	0,350	0,350	0,450
K.1	Gusseisen <200HB	8	12	0,120	0,180	0,180	0,200	0,200	0,230	0,230	0,300	0,300	0,350	0,350	0,400	0,400	0,500
K.2	Temperguss	4	8	0,100	0,120	0,120	0,160	0,160	0,180	0,180	0,250	0,250	0,300	0,300	0,350	0,350	0,500
K.3	Gusseisen mit Kugelgrafit																
N.1	AL <5%	15	20	0,120	0,180	0,180	0,200	0,200	0,230	0,230	0,300	0,300	0,350	0,350	0,400	0,400	0,650
N.2	AL <10%	10	15	0,120	0,180	0,180	0,200	0,200	0,230	0,230	0,300	0,300	0,350	0,350	0,400	0,400	0,650
N.3	AL >10%																
N.4	Ms, Cu, Bronze, Rotguss	10	15	0,150	0,200	0,200	0,250	0,250	0,320	0,320	0,400	0,400	0,450	0,450	0,500	0,500	0,650
N.5	Duro-Thermoplast																
N.6	Grafit, GFK																
S.1	Titan	4	6	0,060	0,080	0,080	0,100	0,100	0,140	0,140	0,200	0,200	0,300	0,300	0,350	0,350	0,450
S.2	Nickel																
H.1	45-52 HRC																
H.2	52-60 HRC																
H.3	60-65 HRC																



RH-R01007

HSSE-REIBAHLE H7 RECHTSSCH./LINKSDRALL



Artikel-Nr. Article-No.	D1	D2	SL	NL	GL	Zähnezahl	Preis/Euro Price/Euro
RH-R01007.0100U.H7	1,0	1,0	2,5	15,0	34	3	28,48 €
RH-R01007.0110U.H7	1,1	1,1	6,5	15,5	36	3	29,39 €
RH-R01007.0120U.H7	1,2	1,2	7,5	16,5	38	3	27,71 €
RH-R01007.0130U.H7	1,3	1,2	7,5	16,5	38	3	26,57 €
RH-R01007.0140U.H7	1,4	1,4	8,0	18,0	40	3	26,57 €
RH-R01007.0150U.H7	1,5	1,5	8,0	18,0	40	3	22,61 €
RH-R01007.0160U.H7	1,6	1,6	9,0	20,0	43	3	25,94 €
RH-R01007.0180U.H7	1,8	1,8	10,0	22,0	46	4	25,57 €
RH-R01007.0200U.H7	2,0	2,0	11,0	24,0	49	4	21,07 €
RH-R01007.0220U.H7	2,2	2,2	12,0	25,0	53	4	25,94 €
RH-R01007.0250U.H7	2,5	2,5	14,0	29,0	57	4	21,11 €
RH-R01007.0280U.H7	2,8	2,8	15,0	33,0	61	6	27,25 €
RH-R01007.0300U.H7	3,0	3,0	15,0	33,0	61	6	20,11 €
RH-R01007.0320U.H7	3,2	3,2	16,0	37,0	65	6	25,57 €
RH-R01007.0350U.H7	3,5	3,5	18,0	42,0	70	6	22,61 €
RH-R01007.0400U.H7	4,0	4,0	19,0	47,0	75	6	19,75 €
RH-R01007.0450U.H7	4,5	4,5	21,0	52,0	80	6	21,16 €
RH-R01007.0500U.H7	5,0	5,0	23,0	58,0	86	6	20,11 €
RH-R01007.0550U.H7	5,5	5,6	26,0	57,0	93	6	22,93 €
RH-R01007.0600U.H7	6,0	5,6	26,0	57,0	93	6	21,25 €
RH-R01007.0650U.H7	6,5	6,3	28,0	65,0	101	6	25,66 €
RH-R01007.0700U.H7	7,0	7,1	31,0	73,0	109	6	25,71 €
RH-R01007.0800U.H7	8,0	8,0	33,0	81,0	117	6	25,34 €
RH-R01007.0900U.H7	9,0	9,0	36,0	85,0	125	6	29,94 €
RH-R01007.1000U.H7	10,0	10,0	38,0	93,0	133	6	30,35 €
RH-R01007.1100U.H7	11,0	10,0	41,0	102,0	142	6	40,00 €
RH-R01007.1200U.H7	12,0	10,0	44,0	111,0	151	6	44,73 €
RH-R01007.1300U.H7	13,0	10,0	44,0	111,0	151	8	53,10 €
RH-R01007.1400U.H7	14,0	12,5	47,0	115,0	160	8	54,51 €
RH-R01007.1500U.H7	15,0	12,5	50,0	117,0	162	8	59,79 €
RH-R01007.1600U.H7	16,0	12,5	52,0	125,0	170	8	61,11 €



RH-R01007

HSSE-REIBAHLE H7 RECHTSSCH./LINKSDRALL

RH-R01007.1700U.H7	17,0	14,0	54,0	130,0	175	8	68,61 €
RH-R01007.1800U.H7	18,0	14,0	56,0	137,0	182	8	70,28 €
RH-R01007.1900U.H7	19,0	16,0	58,0	141,0	189	8	82,16 €
RH-R01007.2000U.H7	20,0	16,0	60,0	147,0	195	8	78,78 €

MATERIALBESCHREIBUNG

		Vc m/min von/bis		f mm/U Ø 0,5-4,99 von/bis		f mm/U Ø 5,0-7,99 von/bis		f mm/U Ø 8,0-11,99 von/bis		f mm/U Ø 12,0-19,99 von/bis		f mm/U Ø 20,0-29,9 von/bis		f mm/U Ø 30,0-39,9 von/bis		f mm/U Ø 40,0-60,0 von/bis	
P.1	<500N/mm	10	12	0,080	0,100	0,100	0,120	0,120	0,160	0,160	0,250	0,250	0,300	0,300	0,360	0,360	0,450
P.2	<650N/mm	8	10	0,080	0,100	0,100	0,120	0,120	0,160	0,160	0,250	0,250	0,300	0,300	0,360	0,360	0,450
P.3	<800N/mm	6	10	0,080	0,100	0,100	0,120	0,120	0,160	0,160	0,250	0,250	0,300	0,300	0,360	0,360	0,450
P.4	<1000N/mm	4	6	0,060	0,080	0,080	0,100	0,100	0,140	0,140	0,200	0,200	0,300	0,300	0,350	0,350	0,450
P.5	<1400N/mm	3	5	0,60	0,080	0,080	0,100	0,100	0,140	0,140	0,200	0,200	0,300	0,300	0,350	0,350	0,450
P.6	Einsatz-ST <1000N/mm	4	6	0,080	0,100	0,100	0,120	0,120	0,160	0,160	0,250	0,250	0,300	0,300	0,360	0,360	0,450
P.7	Nitrier-ST <1000N/mm	4	6	0,060	0,080	0,080	0,100	0,100	0,140	0,140	0,200	0,200	0,300	0,300	0,350	0,350	0,450
P.8	Vergütung-ST 850N/mm	3	5	0,060	0,080	0,080	0,100	0,100	0,140	0,140	0,200	0,200	0,300	0,300	0,350	0,350	0,450
P.9	Werkzeug-ST 1000N/mm	4	8	0,060	0,080	0,080	0,100	0,100	0,140	0,140	0,200	0,200	0,300	0,300	0,350	0,350	0,450
M.1	VA <750N/mm	6	8	0,060	0,080	0,080	0,100	0,100	0,140	0,140	0,200	0,200	0,300	0,300	0,350	0,350	0,450
M.2	VA >750N/mm	4	6	0,060	0,080	0,080	0,100	0,100	0,140	0,140	0,200	0,200	0,300	0,300	0,350	0,350	0,450
K.1	Gusseisen <200HB	8	12	0,120	0,180	0,180	0,200	0,200	0,230	0,230	0,300	0,300	0,350	0,350	0,400	0,400	0,500
K.2	Temperguss	4	8	0,100	0,120	0,120	0,160	0,160	0,180	0,180	0,250	0,250	0,300	0,300	0,350	0,350	0,500
K.3	Gusseisen mit Kugelgrafit																
N.1	AL <5%	15	20	0,120	0,180	0,180	0,200	0,200	0,230	0,230	0,300	0,300	0,350	0,350	0,400	0,400	0,650
N.2	AL <10%	10	15	0,120	0,180	0,180	0,200	0,200	0,230	0,230	0,300	0,300	0,350	0,350	0,400	0,400	0,650
N.3	AL >10%																
N.4	Ms, Cu, Bronze, Rotguss	10	15	0,150	0,200	0,200	0,250	0,250	0,320	0,320	0,400	0,400	0,450	0,450	0,500	0,500	0,650
N.5	Duro-Thermoplast																
N.6	Grafit, GFK																
S.1	Titan	4	6	0,060	0,080	0,080	0,100	0,100	0,140	0,140	0,200	0,200	0,300	0,300	0,350	0,350	0,450
S.2	Nickel																
H.1	45-52 HRC																
H.2	52-60 HRC																
H.3	60-65 HRC																



**HALLAS
TOOLS**

INHALTSVERZEICHNIS KEGELSENKER



Artikel	RH-K09001	RH-K09011	RH-K09002	RH-K09013
Substrat	HSS	HSS-TIN	HSS	HSS-UT
Drm.-Bereich	4,3-40,0	4,3-40,0	6,3-31,0	4,3-31,0
Winkel	90°	90°	90°	90°
DIN	335	335	überlang	335
Zähnezahl	3	3	3	3
Seite	116	120	122	124
P.1	●	●	●	●
P.2	●	●	●	●
P.3	●	●	●	●
P.4	●	●	●	●
P.5	●	●	●	●
P.6	●	●	●	●
P.7	●	●	●	●
P.8	●	●	●	●
P.9	●	●	●	●
M.1	●	●	●	●
M.2	●	●	●	●
K.1	●	●	●	●
K.2	●	●	●	●
K.3				●
N.1	●	●	●	●
N.2	●	●	●	●
N.3	●	●	●	●
N.4	●	●	●	●
N.5	●	●	●	●
N.6				
S.1		●		
S.1				
H.1				
H.2				
H.3				





RH-K09001

HSS-KEGELSENKER 90°

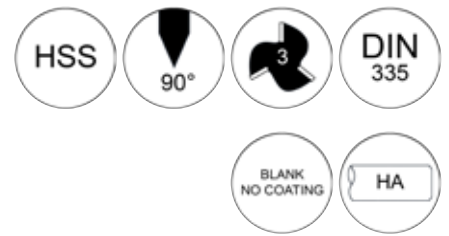

Artikel-Nr. Article-No.	D1	D2	GL	Zähnezahl	Preis/Euro Price/Euro
RH-K09001.0430U.00	4,3	4	40	3	11,64 €
RH-K09001.0500U.00	5	4	40	3	11,64 €
RH-K09001.0530U.00	5,3	4	40	3	11,76 €
RH-K09001.0580U.00	5,8	5	45	3	12,23 €
RH-K09001.0600U.00	6	5	45	3	11,76 €
RH-K09001.0630U.00	6,3	5	45	3	11,76 €
RH-K09001.0700U.00	7	6	50	3	12,87 €
RH-K09001.0730U.00	7,3	6	50	3	12,87 €
RH-K09001.0800U.00	8	6	50	3	12,87 €
RH-K09001.0830U.00	8,3	6	50	3	13,10 €
RH-K09001.0940U.00	9,4	6	50	3	15,50 €
RH-K09001.1000U.00	10	6	50	3	15,50 €
RH-K09001.1040U.00	10,4	6	50	3	15,80 €
RH-K09001.1150U.00	11,5	8	56	3	16,79 €
RH-K09001.1240U.00	12,4	8	56	3	16,79 €
RH-K09001.1340U.00	13,4	8	56	3	18,02 €
RH-K09001.1500U.00	15	10	60	3	19,54 €
RH-K09001.1650U.00	16,5	10	60	3	20,59 €
RH-K09001.1900U.00	19	10	63	3	28,61 €
RH-K09001.2050U.00	20,5	10	63	3	28,61 €
RH-K09001.2500U.00	25	10	67	3	39,49 €
RH-K09001.3100U.00	31	12	71	3	59,20 €
RH-K09001.4000U.00	40	12	75	3	101,32 €



RH-K09001 HSS-KEGELSENKER 90°

MATERIALBESCHREIBUNG

		Vc m/min von/bis		f mm/U		f mm/U		f mm/U		f mm/U		f mm/U		f mm/U		f mm/U	
				Ø 4,3-5,0 von/bis	Ø 6,3-8,0 von/bis	Ø 8,3-12,4 von/bis	Ø 15,0-20,0 von/bis	Ø 20,5-35,0 von/bis	Ø 37,0-60,0 von/bis	Ø 63,0-100,0 von/bis							
P.1	<500N/mm	20	30	0,050	0,080	0,080	0,100	0,100	0,130	0,130	0,160	0,160	0,220	0,220	0,350	0,350	0,450
P.2	<650N/mm	20	30	0,050	0,080	0,080	0,100	0,100	0,130	0,130	0,160	0,160	0,220	0,220	0,350	0,350	0,450
P.3	<800N/mm	15	25	0,050	0,080	0,080	0,100	0,100	0,130	0,130	0,160	0,160	0,220	0,220	0,350	0,350	0,450
P.4	<1000N/mm	15	25	0,040	0,060	0,060	0,070	0,070	0,090	0,090	0,120	0,120	0,160	0,160	0,250	0,250	0,300
P.5	<1400N/mm	2	5	0,020	0,030	0,030	0,040	0,040	0,050	0,050	0,060	0,060	0,100	0,100	0,140	0,140	0,200
P.6	Einsatz-ST <1000N/mm	20	30	0,040	0,060	0,060	0,070	0,070	0,090	0,090	0,120	0,120	0,160	0,160	0,250	0,250	0,300
P.7	Nitrier-ST <1000N/mm	15	25	0,040	0,060	0,060	0,070	0,070	0,090	0,090	0,120	0,120	0,160	0,160	0,250	0,250	0,300
P.8	Vergütung-ST 850N/mm	15	25	0,040	0,060	0,060	0,070	0,070	0,090	0,090	0,120	0,120	0,160	0,160	0,250	0,250	0,300
P.9	Werkzeug-ST 1000N/mm	10	25	0,040	0,060	0,060	0,070	0,070	0,090	0,090	0,120	0,120	0,160	0,160	0,250	0,250	0,300
M.1	VA <750N/mm	0,140	0,200	0,060	0,080	0,080	0,100	0,100	0,140	0,140	0,200	0,200	0,300	0,300	0,350	0,350	0,450
M.2	VA >750N/mm	5	10	0,040	0,050	0,050	0,060	0,060	0,070	0,070	0,080	0,080	0,100	0,100	0,140	0,140	0,200
K.1	Gusseisen <200HB	15	25	0,070	0,080	0,100	0,120	0,120	0,140	0,150	0,200	0,200	0,280	0,280	0,320	0,320	0,400
K.2	Temperguss	10	20	0,060	0,070	0,080	0,090	0,090	0,100	0,120	0,160	0,160	0,250	0,250	0,280	0,280	0,350
K.3	Gusseisen mit Kugelgrafit																
N.1	AL <5%	60	100	0,050	0,080	0,100	0,120	0,120	0,140	0,150	0,200	0,200	0,280	0,280	0,380	0,380	0,450
N.2	AL <10%	30	50	0,050	0,080	0,080	0,100	0,100	0,130	0,130	0,160	0,160	0,220	0,220	0,350	0,350	0,450
N.3	AL >10%	15	30	0,050	0,080	0,080	0,100	0,100	0,130	0,130	0,160	0,160	0,220	0,220	0,350	0,350	0,450
N.4	Ms, Cu, Bronze, Rotguss	40	70	0,050	0,080	0,100	0,120	0,120	0,140	0,150	0,200	0,200	0,280	0,280	0,380	0,380	0,450
N.5	Duro-Thermoplast	20	50	0,050	0,080	0,100	0,120	0,120	0,140	0,150	0,200	0,200	0,280	0,280	0,380	0,380	0,450
N.6	Grafit, GFK																
S.1	Titan																
S.2	Nickel																
H.1	45-52 HRC																
H.2	52-60 HRC																
H.3	60-65 HRC																



RH-K09011

HSS-KEGELSENKER 90° TIN

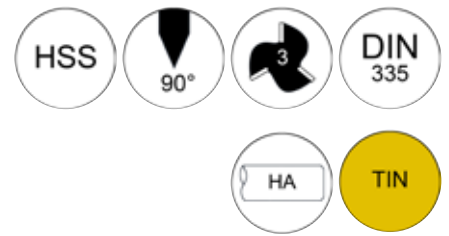

Artikel-Nr. Article-No.	D1	D2	GL	Zähnezahl	Preis/Euro Price/Euro
RH-K09011.0430B.00	4,3	4	40	3	21,19 €
RH-K09011.0500B.00	5	4	40	3	21,19 €
RH-K09011.0530B.00	5,3	4	40	3	21,19 €
RH-K09011.0600B.00	6	5	45	3	21,53 €
RH-K09011.0630B.00	6,3	5	45	3	21,53 €
RH-K09011.0700B.00	7	6	50	3	24,39 €
RH-K09011.0730B.00	7,3	6	50	3	24,39 €
RH-K09011.0800B.00	8	6	50	3	24,39 €
RH-K09011.0830B.00	8,3	6	50	3	24,75 €
RH-K09011.1000B.00	10	6	50	3	29,07 €
RH-K09011.1040B.00	10,4	6	50	3	29,38 €
RH-K09011.1150B.00	11,5	8	56	3	31,41 €
RH-K09011.1240B.00	12,4	8	56	3	31,41 €
RH-K09011.1500B.00	15	10	60	3	36,64 €
RH-K09011.1650B.00	16,5	10	60	3	37,67 €
RH-K09011.1900B.00	19	10	63	3	52,65 €
RH-K09011.2050B.00	20,5	10	63	3	52,65 €
RH-K09011.2500B.00	25	10	67	3	70,80 €
RH-K09011.3100B.00	31	12	71	3	96,54 €
RH-K09011.4000B.00	40	12	75	3	190,42 €



RH-K09011 HSS-KEGELSENKER 90° TIN

MATERIALBESCHREIBUNG

		Vc m/min von/bis		f mm/U		f mm/U		f mm/U		f mm/U		f mm/U		f mm/U		f mm/U	
				Ø 4,3-5,0 von/bis	Ø 6,3-8,0 von/bis	Ø 8,3-12,4 von/bis	Ø 15,0-20,0 von/bis	Ø 20,5-35,0 von/bis	Ø 37,0-60,0 von/bis	Ø 63,0-100,0 von/bis							
P.1	<500N/mm	30	40	0,050	0,080	0,080	0,100	0,100	0,130	0,130	0,160	0,160	0,220	0,220	0,350	0,350	0,045
P.2	<650N/mm	30	40	0,050	0,080	0,080	0,100	0,100	0,130	0,130	0,160	0,160	0,220	0,220	0,350	0,350	0,045
P.3	<800N/mm	20	30	0,050	0,080	0,080	0,100	0,100	0,130	0,130	0,160	0,160	0,220	0,220	0,350	0,350	0,045
P.4	<1000N/mm	20	30	0,040	0,060	0,060	0,070	0,070	0,090	0,090	0,120	0,120	0,160	0,160	0,250	0,250	0,300
P.5	<1400N/mm	3	6	0,020	0,030	0,030	0,040	0,040	0,050	0,050	0,060	0,060	0,100	0,100	0,140	0,140	0,200
P.6	Einsatz-ST <1000N/mm	20	35	0,040	0,060	0,060	0,070	0,070	0,090	0,090	0,120	0,120	0,160	0,160	0,250	0,250	0,300
P.7	Nitrier-ST <1000N/mm	20	30	0,040	0,060	0,060	0,070	0,070	0,090	0,090	0,120	0,120	0,160	0,160	0,250	0,250	0,300
P.8	Vergütung-ST 850N/mm	20	30	0,040	0,060	0,060	0,070	0,070	0,090	0,090	0,120	0,120	0,160	0,160	0,250	0,250	0,300
P.9	Werkzeug-ST 1000N/mm	20	30	0,040	0,060	0,060	0,070	0,070	0,090	0,090	0,120	0,120	0,160	0,160	0,250	0,250	0,300
M.1	VA <750N/mm	5	15	0,040	0,050	0,050	0,060	0,060	0,070	0,070	0,080	0,080	0,100	0,100	0,140	0,140	0,200
M.2	VA >750N/mm	5	15	0,040	0,050	0,050	0,060	0,060	0,070	0,070	0,080	0,080	0,100	0,100	0,140	0,140	0,200
K.1	Gusseisen <200HB	20	30	0,070	0,080	0,100	0,120	0,120	0,140	0,150	0,200	0,200	0,280	0,280	0,320	0,320	0,400
K.2	Temperguss	10	25	0,060	0,070	0,080	0,090	0,090	0,100	0,120	0,160	0,160	0,250	0,250	0,280	0,280	0,350
K.3	Gusseisen mit Kugelgrafit																
N.1	AL <5%	5	120	0,050	0,080	0,100	0,120	0,120	0,140	0,150	0,200	0,200	0,280	0,280	0,380	0,380	0,450
N.2	AL <10%	35	60	0,050	0,080	0,080	0,100	0,100	0,130	0,130	0,160	0,160	0,220	0,220	0,350	0,350	0,450
N.3	AL >10%	15	40	0,050	0,080	0,080	0,100	0,100	0,130	0,130	0,160	0,160	0,220	0,220	0,350	0,350	0,450
N.4	Ms, Cu, Bronze, Rotguss	60	80	0,050	0,080	0,100	0,120	0,120	0,140	0,150	0,200	0,200	0,280	0,280	0,380	0,380	0,450
N.5	Duro-Thermoplast	25	60	0,050	0,080	0,100	0,120	0,120	0,140	0,150	0,200	0,200	0,280	0,280	0,380	0,380	0,450
N.6	Grafit, GFK																
S.1	Titan	5	15	0,040	0,050	0,050	0,060	0,060	0,070	0,070	0,080	0,080	0,100	0,100	0,140	0,140	0,200
S.2	Nickel																
H.1	45-52 HRC																
H.2	52-60 HRC																
H.3	60-65 HRC																



RH-K09002 HSS-KEGELSENKER 90° ÜBERLANG



Artikel-Nr. Article-No.	D1	D2	GL	Zähnezahl	Preis/Euro Price/Euro
RH-K09002.0630U.0L	6,3	5	104	3	37,26 €
RH-K09002.0830U.0L	8,3	6	105	3	39,02 €
RH-K09002.1040U.0L	10,4	6	107	3	42,41 €
RH-K09002.1240U.0L	12,4	8	108	3	43,88 €
RH-K09002.1650U.0L	16,5	10	111	3	54,17 €
RH-K09002.2050U.0L	20,5	10	114	3	76,17 €
RH-K09002.2500U.0L	25	10	118	3	104,72 €
RH-K09002.3100U.0L	31	12	140	3	179,01 €



RH-K09002 HSS-KEGELSENKER 90° ÜBERLANG

MATERIALBESCHREIBUNG

		Vc m/min von/bis		f mm/U		f mm/U		f mm/U		f mm/U		f mm/U		f mm/U		f mm/U	
				Ø 4,3-5,0 von/bis	Ø 6,3-8,0 von/bis	Ø 8,3-12,4 von/bis	Ø 15,0-20,0 von/bis	Ø 20,5-35,0 von/bis	Ø 37,0-60,0 von/bis	Ø 63,0-100,0 von/bis							
P.1	<500N/mm	30	40	0,050	0,080	0,080	0,100	0,100	0,130	0,130	0,160	0,160	0,220	0,220	0,350	0,350	0,045
P.2	<650N/mm	30	40	0,050	0,080	0,080	0,100	0,100	0,130	0,130	0,160	0,160	0,220	0,220	0,350	0,350	0,045
P.3	<800N/mm	20	30	0,050	0,080	0,080	0,100	0,100	0,130	0,130	0,160	0,160	0,220	0,220	0,350	0,350	0,045
P.4	<1000N/mm	20	30	0,040	0,060	0,060	0,070	0,070	0,090	0,090	0,120	0,120	0,160	0,160	0,250	0,250	0,300
P.5	<1400N/mm	3	6	0,020	0,030	0,030	0,040	0,040	0,050	0,050	0,060	0,060	0,100	0,100	0,140	0,140	0,200
P.6	Einsatz-ST <1000N/mm	20	35	0,040	0,060	0,060	0,070	0,070	0,090	0,090	0,120	0,120	0,160	0,160	0,250	0,250	0,300
P.7	Nitrier-ST <1000N/mm	20	30	0,040	0,060	0,060	0,070	0,070	0,090	0,090	0,120	0,120	0,160	0,160	0,250	0,250	0,300
P.8	Vergütung-ST 850N/mm	20	30	0,040	0,060	0,060	0,070	0,070	0,090	0,090	0,120	0,120	0,160	0,160	0,250	0,250	0,300
P.9	Werkzeug-ST 1000N/mm	20	30	0,040	0,060	0,060	0,070	0,070	0,090	0,090	0,120	0,120	0,160	0,160	0,250	0,250	0,300
M.1	VA <750N/mm	5	15	0,040	0,050	0,050	0,060	0,060	0,070	0,070	0,080	0,080	0,100	0,100	0,140	0,140	0,200
M.2	VA >750N/mm	5	15	0,040	0,050	0,050	0,060	0,060	0,070	0,070	0,080	0,080	0,100	0,100	0,140	0,140	0,200
K.1	Gusseisen <200HB	20	30	0,070	0,080	0,100	0,120	0,120	0,140	0,150	0,200	0,200	0,280	0,280	0,320	0,320	0,400
K.2	Temperguss	10	25	0,060	0,070	0,080	0,090	0,090	0,100	0,120	0,160	0,160	0,250	0,250	0,280	0,280	0,350
K.3	Gusseisen mit Kugelgrafit																
N.1	AL <5%	5	120	0,050	0,080	0,100	0,120	0,120	0,140	0,150	0,200	0,200	0,280	0,280	0,380	0,380	0,450
N.2	AL <10%	35	60	0,050	0,080	0,080	0,100	0,100	0,130	0,130	0,160	0,160	0,220	0,220	0,350	0,350	0,450
N.3	AL >10%	15	40	0,050	0,080	0,080	0,100	0,100	0,130	0,130	0,160	0,160	0,220	0,220	0,350	0,350	0,450
N.4	Ms, Cu, Bronze, Rotguss	60	80	0,050	0,080	0,100	0,120	0,120	0,140	0,150	0,200	0,200	0,280	0,280	0,380	0,380	0,450
N.5	Duro-Thermoplast	25	60	0,050	0,080	0,100	0,120	0,120	0,140	0,150	0,200	0,200	0,280	0,280	0,380	0,380	0,450
N.6	Grafit, GFK																
S.1	Titan																
S.2	Nickel																
H.1	45-52 HRC																
H.2	52-60 HRC																
H.3	60-65 HRC																

KEGELSENKER



RH-K09013

HSS-KEGELSENKER 90° UT

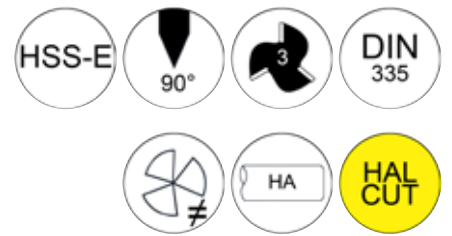

Artikel-Nr. Article-No.	D1	D2	GL	Zähnezahl	Preis/Euro Price/Euro
RH-K09013.0430B.00	4,30	4	40	3	20,80 €
RH-K09013.0530B.00	5,30	4	40	3	20,96 €
RH-K09013.0600B.00	6,00	5	45	3	21,29 €
RH-K09013.0630B.00	6,30	5	45	3	21,29 €
RH-K09013.0800B.00	8,00	6	50	3	26,21 €
RH-K09013.0830B.00	8,30	6	50	3	26,21 €
RH-K09013.0940B.00	9,40	6	50	3	28,57 €
RH-K09013.1000B.00	10,00	6	50	3	28,91 €
RH-K09013.1040B.00	10,40	6	50	3	28,91 €
RH-K09013.1150B.00	11,50	8	56	3	31,62 €
RH-K09013.1200B.00	12,00	8	56	3	32,11 €
RH-K09013.1240B.00	12,40	8	56	3	32,11 €
RH-K09013.1500B.00	15,00	10	60	3	35,49 €
RH-K09013.1650B.00	16,50	10	60	3	36,01 €
RH-K09013.2050B.00	20,50	10	63	3	47,50 €
RH-K09013.2500B.00	25,00	10	67	3	62,04 €
RH-K09013.2800B.00	28,00	12	71	3	87,05 €
RH-K09013.3000B.00	30,00	12	71	3	90,43 €
RH-K09013.3100B.00	31,00	12	71	3	90,43 €



RH-K09013

HSS-KEGELSENKER 90° UT

MATERIALBESCHREIBUNG

		Vc m/min von/bis		f mm/U		f mm/U		f mm/U		f mm/U		f mm/U		f mm/U	
				Ø 4,3-8,0 von/bis	Ø 8,0-12,4 von/bis	Ø 12,4-16,5 von/bis	Ø 16,5-20,5 von/bis	Ø 20,5-25,0 von/bis	Ø 25,0-31,0 von/bis						
P.1	<500N/mm	30	50	0,07	0,10	0,10	0,12	0,12	0,14	0,14	0,18	0,18	0,22	0,22	0,25
P.2	<650N/mm	30	50	0,07	0,10	0,10	0,12	0,12	0,14	0,14	0,18	0,18	0,22	0,22	0,25
P.3	<800N/mm	30	50	0,07	0,10	0,10	0,12	0,12	0,14	0,14	0,18	0,18	0,22	0,22	0,25
P.4	<1000N/mm	30	50	0,07	0,10	0,10	0,12	0,12	0,14	0,14	0,18	0,18	0,22	0,22	0,25
P.5	<1400N/mm	25	35	0,06	0,08	0,08	0,10	0,10	0,12	0,12	0,14	0,14	0,18	0,18	0,20
P.6	Einsatz-ST <1000N/mm	30	40	0,07	0,10	0,10	0,12	0,12	0,14	0,14	0,18	0,18	0,22	0,22	0,25
P.7	Nitrier-ST <1000N/mm	30	40	0,07	0,10	0,10	0,12	0,12	0,14	0,14	0,18	0,18	0,22	0,22	0,25
P.8	Vergütung-ST 850N/mm	30	40	0,07	0,10	0,10	0,12	0,12	0,14	0,14	0,18	0,18	0,22	0,22	0,25
P.9	Werkzeug-ST 1000N/mm	30	40	0,07	0,10	0,10	0,12	0,12	0,14	0,14	0,18	0,18	0,22	0,22	0,25
M.1	VA <750N/mm	10	15	0,05	0,06	0,06	0,07	0,07	0,08	0,08	0,09	0,09	0,12	0,12	0,15
M.2	VA >750N/mm	5	10	0,05	0,06	0,06	0,07	0,07	0,08	0,08	0,09	0,09	0,12	0,12	0,15
K.1	Gusseisen <200HB	15	25	0,10	0,12	0,12	0,14	0,14	0,18	0,18	0,20	0,20	0,25	0,25	0,28
K.2	Temperguss	15	25	0,10	0,12	0,12	0,14	0,14	0,18	0,18	0,20	0,20	0,25	0,25	0,28
K.3	Gusseisen mit Kugelgrafit	15	25	0,10	0,12	0,12	0,14	0,14	0,18	0,18	0,20	0,20	0,25	0,25	0,28
N.1	AL <5%	40	50	0,07	0,10	0,10	0,12	0,12	0,14	0,14	0,18	0,18	0,22	0,22	0,25
N.2	AL <10%	40	50	0,07	0,10	0,10	0,12	0,12	0,14	0,14	0,18	0,18	0,22	0,22	0,25
N.3	AL >10%	35	45	0,10	0,12	0,12	0,14	0,14	0,18	0,18	0,20	0,20	0,24	0,24	0,28
N.4	Ms, Cu, Bronze, Rotguss	40	50	0,10	0,12	0,12	0,14	0,14	0,18	0,18	0,20	0,20	0,24	0,24	0,28
N.5	Duro-Thermoplast	40	50	0,10	0,12	0,12	0,14	0,14	0,18	0,18	0,20	0,20	0,24	0,24	0,28
N.6	Grafit, GFK														
S.1	Titan														
S.2	Nickel														
H.1	45-52 HRC														
H.2	52-60 HRC														
H.3	60-65 HRC														

KEGELSENKER





BESCHREIBUNG WERKZEUGE

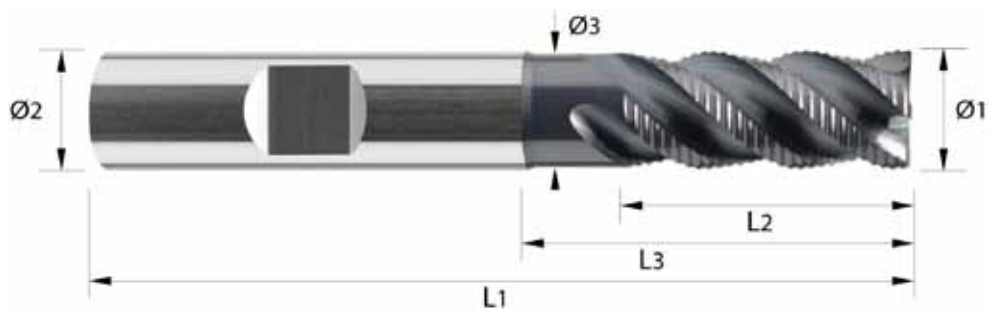
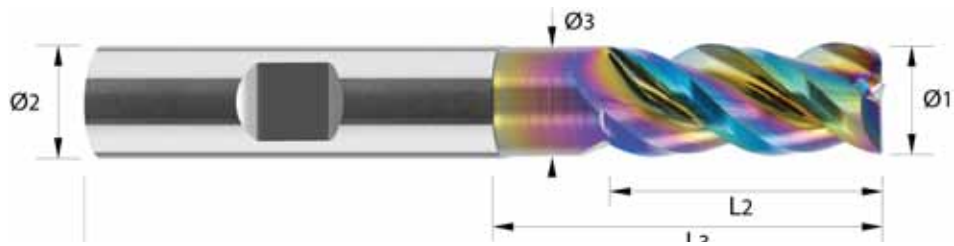
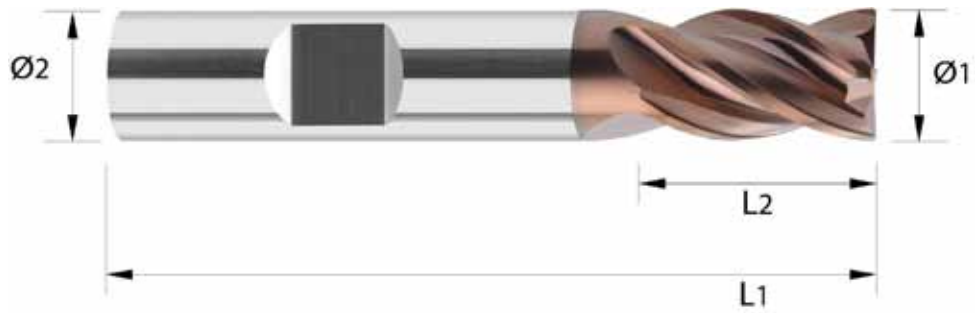

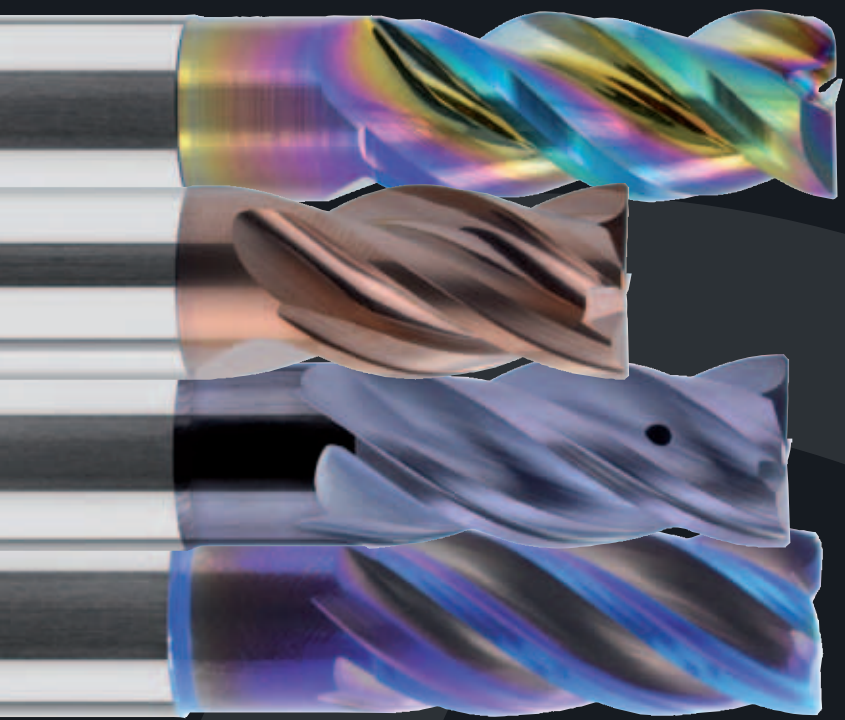

HALLAS
TOOLS

FRÄSWERKZEUGE



INHALTSVERZEICHNIS FRÄSWERKZEUGE



Artikel	FV-HPC101	FV-HPC102	FV-HPC103	FV-HPC104	FV-MTC120	FV-FIN530	FV-HPC205	FV-HPC206	FV-HPC510
Substrat	VHM	VHM	VHM	VHM	VHM	VHM	VHM	VHM	VHM
Drn.-Bereich	3-20	3-20	3-20	3-20	6-20	3-25	3-20	3-20	3-20
Länge	kurz	lang abgesetzt	kurz	lang abgesetzt	lang abgesetzt	lang abgesetzt	kurz	lang abgesetzt	kurz
Schaftart	HB	HB	HB	HB	HB	HA	HB	HB	HB
Zähnezahl	4	4	4	4	4	5-6	4	4	4
Seite	132	134	136	138	140	142	144	146	148
P.1	●	●	●	●	●	●	●	●	●
P.2	●	●	●	●	●	●	●	●	●
P.3	●	●	●	●	●	●	●	●	●
P.4	●	●	●	●	●	●			
P.5	●	●	●	●	●	●			
P.6	●	●	●	●	●	●			
P.7	●	●	●	●	●	●			
P.8	●	●	●	●	●	●			
P.9	●	●	●	●	●	●			
M.1					●	●	●	●	●
M.2					●	●	●	●	●
K.1	●	●	●	●	●	●	●	●	●
K.2	●	●	●	●	●	●	●	●	●
K.3	●	●	●	●	●	●	●	●	●
N.1	●	●							
N.2	●	●							
N.3	●	●							
N.4	●	●							
N.5	●	●							
N.6									
S.1					●		●	●	●
S.1					●		●	●	●
H.1									
H.2									
H.3									

FRÄSWERKZEUGE



INHALTSVERZEICHNIS FRÄSWERKZEUGE



Artikel	FV-HPC511	FV-MTC221	FV-FIN231	FV-KON362	FV-KON360	FV-HPC361	FV-MTC365	FV-MTC375
Substrat	VHM	VHM	VHM	VHM	VHM	VHM	VHM	VHM
Drm.-Bereich	3-20	4-25	6-20	1-12	1-20	3-20	6-20	6-20
Länge	lang abgesetzt	lang abgesetzt	überlang	kurz	lang	lang abgesetzt	lang abgesetzt	lang abgesetzt
Schaftart	HB	HB	HB	HA	HA	HA	HA	HA
Zähnezahl	4	3-6	5	1	2	3	3	3
Seite	150	152	154	156	158	160	162	164

P.1	●	●	●					
P.2	●	●	●					
P.3	●	●	●					
P.4		●	●					
P.5		●	●					
P.6		●	●					
P.7		●	●					
P.8		●	●					
P.9		●	●					
M.1	●	●	●					
M.2	●	●	●					
K.1	●	●	●					
K.2	●	●	●					
K.3	●	●	●					
N.1			●	●	●	●	●	●
N.2				●	●	●	●	●
N.3				●	●	●	●	●
N.4			●	●	●	●	●	●
N.5				●	●	●	●	●
N.6								
S.1	●		●					
S.1	●		●					
H.1								
H.2								
H.3								



FV-HPC101

VHM-HPC-HOCHLEISTUNGSFRÄSER "ECOLIX-STEEL" KURZ

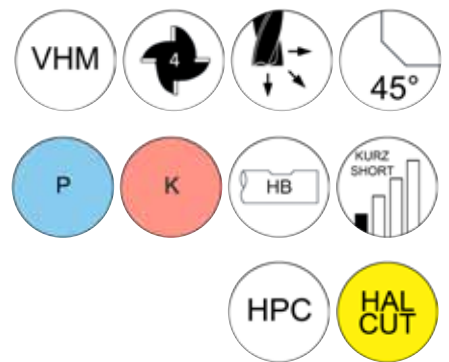

Artikel-Nr. Article-No.	D1	D2	L2	L1	Z	EF	Preis/Euro Price/Euro
FV-HPC101.0300K.ST	3	6	6	54	4	0,10	22,44 €
FV-HPC101.0400K.ST	4	6	8	54	4	0,13	22,44 €
FV-HPC101.0500K.ST	5	6	9	54	4	0,18	22,44 €
FV-HPC101.0600K.ST	6	6	10	54	4	0,20	22,44 €
FV-HPC101.0800K.ST	8	8	12	58	4	0,20	29,49 €
FV-HPC101.1000K.ST	10	10	14	66	4	0,20	39,46 €
FV-HPC101.1200K.ST	12	12	16	73	4	0,30	53,72 €
FV-HPC101.1400K.ST	14	14	18	75	4	0,30	70,23 €
FV-HPC101.1600K.ST	16	16	22	82	4	0,30	91,43 €
FV-HPC101.1800K.ST	18	18	24	84	4	0,40	119,97 €
FV-HPC101.2000K.ST	20	20	26	92	4	0,40	133,57 €





FV-HPC101

VHM-HPC-HOCHLEISTUNGSFRÄSER "ECOLIX-STEEL" KURZ

MATERIALBESCHREIBUNG

		Vc m/min von/bis		fz		fz		fz		fz		fz		fz	
				Ø 3,0-4,0 von/bis	Ø 4,0-6,0 von/bis	Ø 6,0-10,0 von/bis	Ø 10,0-16,0 von/bis	Ø 16,0-20,0 von/bis	Ø 20,0-25,0 von/bis						
P.1	<500N/mm														
P.2	<650N/mm	180	200	0,012	0,020	0,020	0,035	0,035	0,075	0,075	0,100	0,100	0,120	0,012	0,130
P.3	<800N/mm	170	190	0,012	0,020	0,020	0,035	0,035	0,075	0,075	0,100	0,100	0,120	0,012	0,130
P.4	<1000N/mm	150	170	0,009	0,015	0,015	0,025	0,025	0,052	0,052	0,070	0,070	0,084	0,084	0,091
P.5	<1400N/mm	110	130	0,006	0,015	0,015	0,025	0,025	0,052	0,052	0,070	0,070	0,084	0,084	0,100
P.6	Einsatz-ST <1000N/mm	140	160	0,009	0,015	0,015	0,025	0,025	0,052	0,052	0,070	0,070	0,084	0,084	0,091
P.7	Nitrier-ST <1000N/mm	140	160	0,009	0,015	0,015	0,025	0,025	0,052	0,052	0,070	0,070	0,084	0,084	0,091
P.8	Vergütung-ST 850N/mm	160	180	0,012	0,020	0,020	0,035	0,045	0,075	0,075	0,100	0,100	0,120	0,120	0,130
P.9	Werkzeug-ST 1000N/mm	70	90	0,009	0,015	0,015	0,025	0,025	0,052	0,052	0,070	0,070	0,084	0,084	0,091
M.1	VA <750N/mm														
M.2	VA >750N/mm														
K.1	Gusseisen <200HB	190	210	0,012	0,020	0,020	0,035	0,045	0,075	0,075	0,100	0,100	0,120	0,012	0,130
K.2	Temperguss	140	160	0,012	0,020	0,020	0,035	0,045	0,075	0,075	0,100	0,100	0,120	0,012	0,130
K.3	Gusseisen mit Kugelgrafit	140	160	0,012	0,020	0,020	0,035	0,045	0,075	0,075	0,100	0,100	0,120	0,012	0,130
N.1	AL <5%														
N.2	AL <10%														
N.3	AL >10%														
N.4	Ms, Cu, Bronze, Rotguss														
N.5	Duro-Thermoplast														
N.6	Grafit, GFK														
S.1	Titan														
S.2	Nickel														
H.1	45-52 HRC														
H.2	52-60 HRC														
H.3	60-65 HRC														



FV-HPC102

VHM-HPC-HOCHLEISTUNGSFRÄSER "ECOLIX-STEEL" LANG

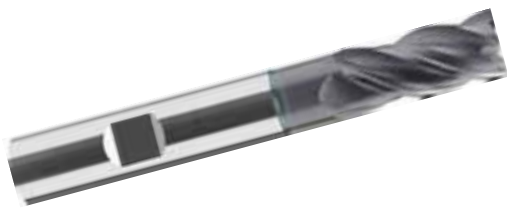
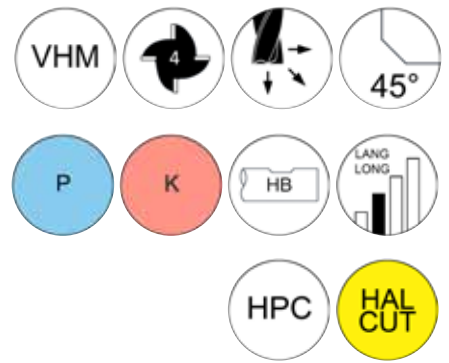

Artikel-Nr. Article-No.	D1	D2	D3	L2	L3	L1	Z	EF	Preis/Euro Price/Euro
FV-HPC102.0300L.ST	3	6	2,8	8	18	57	4	0,13	30,38 €
FV-HPC102.0400L.ST	4	6	3,6	11	21	57	4	0,13	30,38 €
FV-HPC102.0500L.ST	5	6	4,6	13	21	57	4	0,20	30,38 €
FV-HPC102.0600L.ST	6	6	5,5	13	21	57	4	0,20	30,38 €
FV-HPC102.0800L.ST	8	8	7,5	19	27	63	4	0,20	42,14 €
FV-HPC102.1000L.ST	10	10	9,50	22	32	72	4	0,20	52,81 €
FV-HPC102.1200L.ST	12	12	11,5	26	38	83	4	0,30	72,66 €
FV-HPC102.1400L.ST	14	14	13,5	26	42	83	4	0,30	97,42 €
FV-HPC102.1600L.ST	16	16	15,5	32	44	92	4	0,30	111,29 €
FV-HPC102.1800L.ST	18	18	17,5	32	50	92	4	0,40	141,79 €
FV-HPC102.2000L.ST	20	20	19,5	38	54	104	4	0,40	164,44 €





FV-HPC102

VHM-HPC-HOCHLEISTUNGSFRÄSER "ECOLIX-STEEL" LANG

MATERIALBESCHREIBUNG

		Vc m/min von/bis		fz		fz		fz		fz		fz		fz	
				Ø 3,0-4,0 von/bis	Ø 4,0-6,0 von/bis	Ø 6,0-10,0 von/bis	Ø 10,0-16,0 von/bis	Ø 16,0-20,0 von/bis	Ø 20,0-25,0 von/bis						
P.1	<500N/mm														
P.2	<650N/mm	180	200	0,012	0,020	0,020	0,035	0,035	0,075	0,075	0,100	0,100	0,120	0,012	0,130
P.3	<800N/mm	170	190	0,012	0,020	0,020	0,035	0,035	0,075	0,075	0,100	0,100	0,120	0,012	0,130
P.4	<1000N/mm	150	170	0,009	0,015	0,015	0,025	0,025	0,052	0,052	0,070	0,070	0,084	0,084	0,091
P.5	<1400N/mm	110	130	0,006	0,015	0,015	0,025	0,025	0,052	0,052	0,070	0,070	0,084	0,084	0,100
P.6	Einsatz-ST <1000N/mm	140	160	0,009	0,015	0,015	0,025	0,025	0,052	0,052	0,070	0,070	0,084	0,084	0,091
P.7	Nitrier-ST <1000N/mm	140	160	0,009	0,015	0,015	0,025	0,025	0,052	0,052	0,070	0,070	0,084	0,084	0,091
P.8	Vergütung-ST 850N/mm	160	180	0,012	0,020	0,020	0,035	0,045	0,075	0,075	0,100	0,100	0,120	0,120	0,130
P.9	Werkzeug-ST 1000N/mm	70	90	0,009	0,015	0,015	0,025	0,025	0,052	0,052	0,070	0,070	0,084	0,084	0,091
M.1	VA <750N/mm														
M.2	VA >750N/mm														
K.1	Gusseisen <200HB	190	210	0,012	0,020	0,020	0,035	0,045	0,075	0,075	0,100	0,100	0,120	0,012	0,130
K.2	Temperguss	140	160	0,012	0,020	0,020	0,035	0,045	0,075	0,075	0,100	0,100	0,120	0,012	0,130
K.3	Gusseisen mit Kugelgrafit	140	160	0,012	0,020	0,020	0,035	0,045	0,075	0,075	0,100	0,100	0,120	0,012	0,130
N.1	AL <5%														
N.2	AL <10%														
N.3	AL >10%														
N.4	Ms, Cu, Bronze, Rotguss														
N.5	Duro-Thermoplast														
N.6	Grafit, GFK														
S.1	Titan														
S.2	Nickel														
H.1	45-52 HRC														
H.2	52-60 HRC														
H.3	60-65 HRC														



FV-HPC103

VHM-HPC-HOCHLEISTUNGSFRÄSER "STEELIX" KURZ

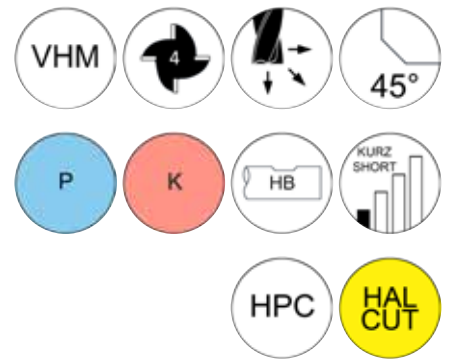

Artikel-Nr. Article-No.	D1	D2	L2	L1	Z	EF	Preis/Euro Price/Euro
FV-HPC103.0300K.ST	3	6	6	54	4	0,06	42,54 €
FV-HPC103.0400K.ST	4	6	8	54	4	0,08	42,54 €
FV-HPC103.0500K.ST	5	6	9	54	4	0,10	42,54 €
FV-HPC103.0600K.ST	6	6	10	54	4	0,13	42,54 €
FV-HPC103.0800K.ST	8	8	12	58	4	0,15	53,61 €
FV-HPC103.1000K.ST	10	10	14	66	4	0,20	77,30 €
FV-HPC103.1200K.ST	12	12	16	73	4	0,25	102,28 €
FV-HPC103.1600K.ST	16	16	22	82	4	0,35	191,72 €
FV-HPC103.2000K.ST	20	20	26	92	4	0,40	251,37 €





FV-HPC103

VHM-HPC-HOCHLEISTUNGSFRÄSER "STEELIX" KURZ

MATERIALBESCHREIBUNG

		Vc m/min von/bis		fz		fz		fz		fz		fz		fz	
				Ø 3,0-4,0 von/bis	Ø 4,0-6,0 von/bis	Ø 6,0-10,0 von/bis	Ø 10,0-16,0 von/bis	Ø 16,0-20,0 von/bis	Ø 20,0-25,0 von/bis						
P.1	<500N/mm														
P.2	<650N/mm	180	200	0,012	0,020	0,020	0,035	0,035	0,075	0,075	0,100	0,100	0,120	0,012	0,130
P.3	<800N/mm	170	190	0,012	0,020	0,020	0,035	0,035	0,075	0,075	0,100	0,100	0,120	0,012	0,130
P.4	<1000N/mm	150	170	0,009	0,015	0,015	0,025	0,025	0,052	0,052	0,070	0,070	0,084	0,084	0,091
P.5	<1400N/mm	110	130	0,006	0,015	0,015	0,025	0,025	0,052	0,052	0,070	0,070	0,084	0,084	0,100
P.6	Einsatz-ST <1000N/mm	140	160	0,009	0,015	0,015	0,025	0,025	0,052	0,052	0,070	0,070	0,084	0,084	0,091
P.7	Nitrier-ST <1000N/mm	140	160	0,009	0,015	0,015	0,025	0,025	0,052	0,052	0,070	0,070	0,084	0,084	0,091
P.8	Vergütung-ST 850N/mm	160	180	0,012	0,020	0,020	0,035	0,045	0,075	0,075	0,100	0,100	0,120	0,120	0,130
P.9	Werkzeug-ST 1000N/mm	70	90	0,009	0,015	0,015	0,025	0,025	0,052	0,052	0,070	0,070	0,084	0,084	0,091
M.1	VA <750N/mm														
M.2	VA >750N/mm														
K.1	Gusseisen <200HB	190	210	0,012	0,020	0,020	0,035	0,045	0,075	0,075	0,100	0,100	0,120	0,012	0,130
K.2	Temperguss	140	160	0,012	0,020	0,020	0,035	0,045	0,075	0,075	0,100	0,100	0,120	0,012	0,130
K.3	Gusseisen mit Kugelgraphit	140	160	0,012	0,020	0,020	0,035	0,045	0,075	0,075	0,100	0,100	0,120	0,012	0,130
N.1	AL <5%														
N.2	AL <10%														
N.3	AL >10%														
N.4	Ms, Cu, Bronze, Rotguss														
N.5	Duro-Thermoplast														
N.6	Graphit, GFK														
S.1	Titan														
S.2	Nickel														
H.1	45-52 HRC														
H.2	52-60 HRC														
H.3	60-65 HRC														



FV-HPC104

VHM-HPC-HOCHLEISTUNGSFRÄSER "STEELIX" LANG

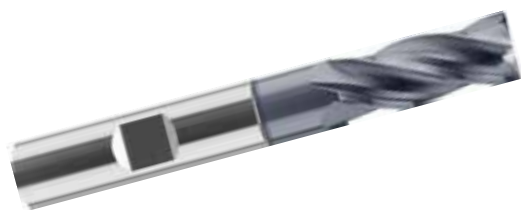
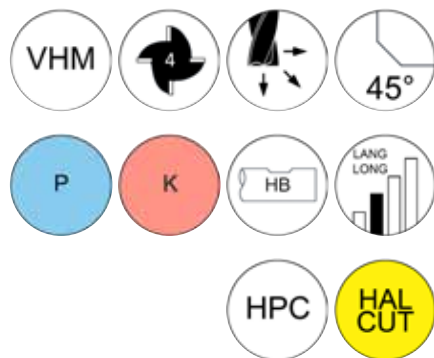

Artikel-Nr. Article-No.	D1	D2	D3	L2	L3	L1	Z	EF	Preis/Euro Price/Euro
FV-HPC104.0300L.ST	3	6	2,8	8	18	57	4	0,06	47,14 €
FV-HPC104.0400L.ST	4	6	3,6	11	21	57	4	0,08	47,14 €
FV-HPC104.0500L.ST	5	6	4,6	13	21	57	4	0,10	47,14 €
FV-HPC104.0600L.ST	6	6	5,5	13	21	57	4	0,13	47,14 €
FV-HPC104.0800L.ST	8	8	7,5	19	27	63	4	0,15	59,64 €
FV-HPC104.1000L.ST	10	10	9,5	22	32	72	4	0,20	85,59 €
FV-HPC104.1200L.ST	12	12	11,5	26	38	83	4	0,25	113,46 €
FV-HPC104.1600L.ST	16	16	15,5	32	44	92	4	0,35	220,58 €
FV-HPC104.2000L.ST	20	20	19,5	38	54	104	4	0,40	279,01 €





FV-HPC104

VHM-HPC-HOCHLEISTUNGSFRÄSER "STEELIX" LANG

MATERIALBESCHREIBUNG

		Vc m/min von/bis		fz		fz		fz		fz		fz		fz	
				Ø 3,0-4,0 von/bis	Ø 4,0-6,0 von/bis	Ø 6,0-10,0 von/bis	Ø 10,0-16,0 von/bis	Ø 16,0-20,0 von/bis	Ø 20,0-25,0 von/bis						
P.1	<500N/mm														
P.2	<650N/mm	180	200	0,012	0,020	0,020	0,035	0,035	0,075	0,075	0,100	0,100	0,120	0,012	0,130
P.3	<800N/mm	170	190	0,012	0,020	0,020	0,035	0,035	0,075	0,075	0,100	0,100	0,120	0,012	0,130
P.4	<1000N/mm	150	170	0,009	0,015	0,015	0,025	0,025	0,052	0,052	0,070	0,070	0,084	0,084	0,091
P.5	<1400N/mm	110	130	0,006	0,015	0,015	0,025	0,025	0,052	0,052	0,070	0,070	0,084	0,084	0,100
P.6	Einsatz-ST <1000N/mm	140	160	0,009	0,015	0,015	0,025	0,025	0,052	0,052	0,070	0,070	0,084	0,084	0,091
P.7	Nitrier-ST <1000N/mm	140	160	0,009	0,015	0,015	0,025	0,025	0,052	0,052	0,070	0,070	0,084	0,084	0,091
P.8	Vergütung-ST 850N/mm	160	180	0,012	0,020	0,020	0,035	0,045	0,075	0,075	0,100	0,100	0,120	0,120	0,130
P.9	Werkzeug-ST 1000N/mm	70	90	0,009	0,015	0,015	0,025	0,025	0,052	0,052	0,070	0,070	0,084	0,084	0,091
M.1	VA <750N/mm														
M.2	VA >750N/mm														
K.1	Gusseisen <200HB	190	210	0,012	0,020	0,020	0,035	0,045	0,075	0,075	0,100	0,100	0,120	0,012	0,130
K.2	Temperguss	140	160	0,012	0,020	0,020	0,035	0,045	0,075	0,075	0,100	0,100	0,120	0,012	0,130
K.3	Gusseisen mit Kugelgraphit	140	160	0,012	0,020	0,020	0,035	0,045	0,075	0,075	0,100	0,100	0,120	0,012	0,130
N.1	AL <5%														
N.2	AL <10%														
N.3	AL >10%														
N.4	Ms, Cu, Bronze, Rotguss														
N.5	Duro-Thermoplast														
N.6	Graphit, GFK														
S.1	Titan														
S.2	Nickel														
H.1	45-52 HRC														
H.2	52-60 HRC														
H.3	60-65 HRC														



FV-MTC120

VHM-MTC-HOCHLEISTUNGSFRÄSER TYP NR

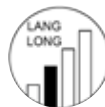

Artikel-Nr. Article-No.	D1	D2	D3	L2	L3	L1	Z	EF	Preis/Euro Price/Euro
FV-MTC120.0600L.ST	6	6	5,5	13	21	57,0	4	0,50	65,72 €
FV-MTC120.0800L.ST	8	8	7,5	19	27	63,0	4	0,50	73,31 €
FV-MTC120.1000L.ST	10	10	9,5	22	32	72,0	4	0,50	85,93 €
FV-MTC120.1200L.ST	12	12	11,5	26	38	83,0	4	0,50	98,57 €
FV-MTC120.1600L.ST	16	16	15,5	32	44	92,0	4	1,00	170,63 €
FV-MTC120.2000L.ST	20	20	19,5	38	54	104,0	4	1,00	259,66 €



FV-MTC120

VHM-MTC-HOCHLEISTUNGSFRÄSER TYP NR

MATERIALBESCHREIBUNG

		Vc m/min von/bis		fz		fz		fz		fz		fz	
				Ø 4,0-6,0 von/bis	Ø 6,0-10,0 von/bis	Ø 10,0-16,0 von/bis	Ø 16,0-20,0 von/bis	Ø 20,0-25,0 von/bis	Ø 20,0-25,0 von/bis	Ø 20,0-25,0 von/bis	Ø 20,0-25,0 von/bis		
P.1	<500N/mm	170	200	0,020	0,035	0,035	0,075	0,075	0,100	0,100	0,120	0,120	0,140
P.2	<650N/mm	160	190	0,020	0,035	0,035	0,075	0,075	0,100	0,100	0,120	0,120	0,140
P.3	<800N/mm	150	180	0,020	0,035	0,035	0,075	0,075	0,100	0,100	0,120	0,120	0,140
P.4	<1000N/mm	120	150	0,015	0,025	0,025	0,050	0,050	0,070	0,070	0,085	0,085	0,100
P.5	<1400N/mm	100	130	0,015	0,025	0,025	0,050	0,050	0,070	0,070	0,085	0,085	0,100
P.6	Einsatz-ST <1000N/mm	110	140	0,015	0,025	0,025	0,050	0,050	0,070	0,070	0,085	0,085	0,100
P.7	Nitrier-ST <1000N/mm	110	140	0,015	0,025	0,025	0,050	0,050	0,070	0,070	0,085	0,085	0,100
P.8	Vergütung-ST 850N/mm	140	170	0,020	0,035	0,035	0,075	0,075	0,100	0,100	0,120	0,120	0,140
P.9	Werkzeug-ST 1000N/mm	100	130	0,015	0,025	0,025	0,050	0,050	0,070	0,070	0,085	0,085	0,100
M.1	VA <750N/mm	80	100	0,020	0,035	0,035	0,075	0,075	0,100	0,100	0,120	0,120	0,140
M.2	VA >750N/mm	50	70	0,015	0,025	0,025	0,050	0,050	0,070	0,070	0,085	0,085	0,100
K.1	Gusseisen <200HB	30	180	0,020	0,035	0,035	0,075	0,075	0,100	0,100	0,120	0,120	0,140
K.2	Temperguss	105	130	0,020	0,035	0,035	0,075	0,075	0,100	0,100	0,120	0,120	0,140
K.3	Gusseisen mit Kugelgrafit	105	130	0,020	0,035	0,035	0,075	0,075	0,100	0,100	0,120	0,120	0,140
N.1	AL <5%												
N.2	AL <10%												
N.3	AL >10%												
N.4	Ms, Cu, Bronze, Rotguss												
N.5	Duro-Thermoplast												
N.6	Grafit, GFK												
S.1	Titan	30	50	0,015	0,025	0,025	0,050	0,050	0,070	0,070	0,085	0,085	0,100
S.2	Nickel	30	50	0,015	0,025	0,025	0,050	0,050	0,070	0,070	0,085	0,085	0,100
H.1	45-52 HRC												
H.2	52-60 HRC												
H.3	60-65 HRC												



FV-FIN530

VHM-HPC-EXTREMSCHLICHTFRÄSER "FINISHIX"

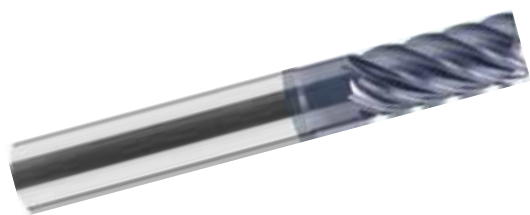
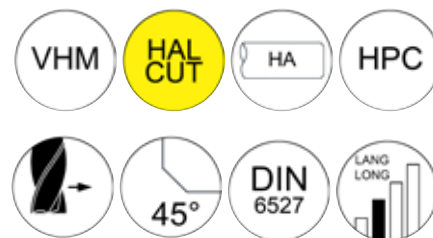

Artikel-Nr. Article-No.	D1	D2	L2	L1	Z	EF	Preis/Euro Price/Euro
FV-FIN530.0300L.UN	3	6	8	57	5	0,05	45,95 €
FV-FIN530.0400L.UN	4	6	11	57	6	0,10	45,95 €
FV-FIN530.0500L.UN	5	6	13	57	6	0,10	45,95 €
FV-FIN530.0600L.UN	6	6	13	57	6	0,10	45,95 €
FV-FIN530.0800L.UN	8	8	19	63	6	0,10	56,46 €
FV-FIN530.1000L.UN	10	10	22	72	6	0,10	90,59 €
FV-FIN530.1200L.UN	12	12	26	83	6	0,10	120,81 €
FV-FIN530.1600L.UN	16	16	32	92	6	0,20	216,65 €
FV-FIN530.2000L.UN	20	20	38	104	6	0,20	308,57 €
FV-FIN530.2500L.UN	25	25	42	110	6	0,20	474,01 €





FV-FIN530

VHM-HPC-EXTREMSCHLICHTFRÄSER "FINISHIX"

MATERIALBESCHREIBUNG

		Vc m/min von/bis		fz		fz		fz		fz	
				Ø 6,0-10,0 von/bis		Ø10,0-12,0 von/bis		Ø12,0-16,0 von/bis		Ø 16,0-25,0 von/bis	
P.1	<500N/mm	220	240	0,035	0,040	0,040	0,055	0,055	0,070	0,070	0,100
P.2	<650N/mm	190	210	0,035	0,040	0,040	0,055	0,055	0,070	0,070	0,100
P.3	<800N/mm	170	190	0,035	0,040	0,040	0,055	0,055	0,070	0,070	0,100
P.4	<1000N/mm	170	190	0,035	0,040	0,040	0,055	0,055	0,070	0,070	0,100
P.5	<1400N/mm	130	150	0,030	0,035	0,035	0,045	0,045	0,060	0,060	0,090
P.6	Einsatz-ST <1000N/mm	150	170	0,035	0,040	0,040	0,055	0,055	0,070	0,070	0,100
P.7	Nitrier-ST <1000N/mm	150	170	0,035	0,040	0,040	0,055	0,055	0,070	0,070	0,100
P.8	Vergütung-ST 850N/mm	160	180	0,035	0,040	0,040	0,055	0,055	0,070	0,070	0,100
P.9	Werkzeug-ST 1000N/mm	130	150	0,030	0,035	0,035	0,045	0,045	0,060	0,060	0,090
M.1	VA <750N/mm	80	100	0,035	0,040	0,040	0,055	0,055	0,070	0,070	0,100
M.2	VA >750N/mm	40	60	0,030	0,035	0,035	0,045	0,045	0,060	0,060	0,090
K.1	Gusseisen <200HB	150	170	0,035	0,040	0,040	0,055	0,055	0,070	0,070	0,100
K.2	Temperguss	110	130	0,035	0,040	0,040	0,055	0,055	0,070	0,070	0,100
K.3	Gusseisen mit Kugelgraphit	110	130	0,035	0,040	0,040	0,055	0,055	0,070	0,070	0,100
N.1	AL <5%										
N.2	AL <10%										
N.3	AL >10%										
N.4	Ms, Cu, Bronze, Rotguss										
N.5	Duro-Thermoplast										
N.6	Grafit, GFK										
S.1	Titan										
S.2	Nickel										
H.1	45-52 HRC										
H.2	52-60 HRC										
H.3	60-65 HRC										



FV-HPC205

VHM-HPC-HOCHLEISTUNGSFRÄSER "ECOLIX-INOX" KURZ

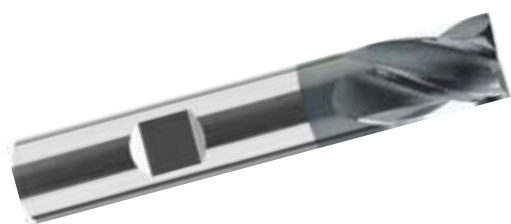
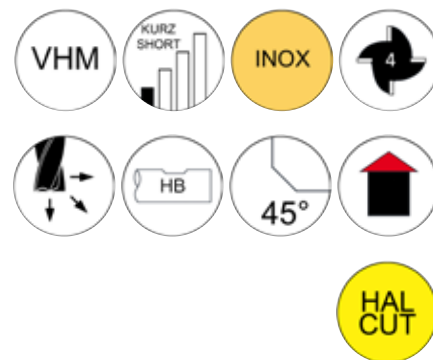

Artikel-Nr. Article-No.	D1	D2	L2	L1	Z	EF	Preis/Euro Price/Euro
FV-HPC205.0300K.VA	3	6	6	54	4	0,10	27,69 €
FV-HPC205.0400K.VA	4	6	8	54	4	1,13	27,69 €
FV-HPC205.0500K.VA	5	6	9	54	4	0,18	27,69 €
FV-HPC205.0600K.VA	6	6	10	54	4	0,20	27,69 €
FV-HPC205.0800K.VA	8	8	12	58	4	0,20	34,01 €
FV-HPC205.1000K.VA	10	10	14	66	4	0,20	47,76 €
FV-HPC205.1200K.VA	12	12	16	73	4	0,30	67,24 €
FV-HPC205.1600K.VA	16	16	22	82	4	0,30	115,26 €
FV-HPC205.2000K.VA	20	20	26	92	4	0,40	172,75 €





FV-HPC205

VHM-HPC-HOCHLEISTUNGSFRÄSER "ECOLIX-INOX" KURZ

MATERIALBESCHREIBUNG

		Vc m/min von/bis		fz		fz		fz		fz		fz		fz	
				Ø 3,0-4,0 von/bis		Ø 4,0-6,0 von/bis		Ø 6,0-10,0 von/bis		Ø 10,0-16,0 von/bis		Ø 16,0-20,0 von/bis		Ø 20,0-25,0 von/bis	
P.1	<500N/mm	220	240	0,012	0,020	0,020	0,035	0,035	0,075	0,075	0,100	0,100	0,120	0,012	0,130
P.2	<650N/mm	200	220	0,012	0,020	0,020	0,035	0,035	0,075	0,075	0,100	0,100	0,120	0,012	0,130
P.3	<800N/mm	165	185	0,012	0,020	0,020	0,035	0,035	0,075	0,075	0,100	0,100	0,120	0,012	0,130
P.4	<1000N/mm														
P.5	<1400N/mm														
P.6	Einsatz-ST <1000N/mm														
P.7	Nitrier-ST <1000N/mm														
P.8	Vergütung-ST 850N/mm														
P.9	Werkzeug-ST 1000N/mm														
M.1	VA <750N/mm	85	100	0,012	0,020	0,020	0,035	0,045	0,075	0,075	0,100	0,100	0,120	0,012	0,130
M.2	VA >750N/mm	45	65	0,009	0,015	0,015	0,025	0,025	0,052	0,052	0,070	0,070	0,084	0,084	0,091
K.1	Gusseisen <200HB	180	200	0,012	0,020	0,020	0,035	0,045	0,075	0,075	0,100	0,100	0,120	0,012	0,130
K.2	Temperguss	130	150	0,012	0,020	0,020	0,035	0,045	0,075	0,075	0,100	0,100	0,120	0,012	0,130
K.3	Gusseisen mit Kugelgrafit	130	150	0,012	0,020	0,020	0,035	0,045	0,075	0,075	0,100	0,100	0,120	0,012	0,130
N.1	AL <5%														
N.2	AL <10%														
N.3	AL >10%														
N.4	Ms, Cu, Bronze, Rotguss														
N.5	Duro-Thermoplast														
N.6	Grafit, GFK														
S.1	Titan	55	65	0,009	0,015	0,015	0,025	0,025	0,052	0,052	0,070	0,070	0,084	0,084	0,091
S.2	Nickel	55	65	0,009	0,015	0,015	0,025	0,025	0,052	0,052	0,070	0,070	0,084	0,084	0,091
H.1	45-52 HRC														
H.2	52-60 HRC														
H.3	60-65 HRC														



FV-HPC206

VHM-HPC-HOCHLEISTUNGSFRÄSER "ECOLIX-INOX" LANG

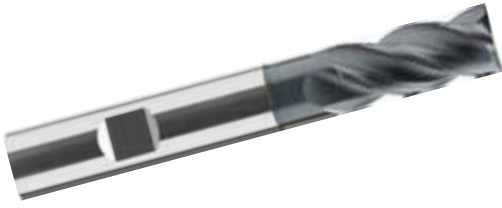
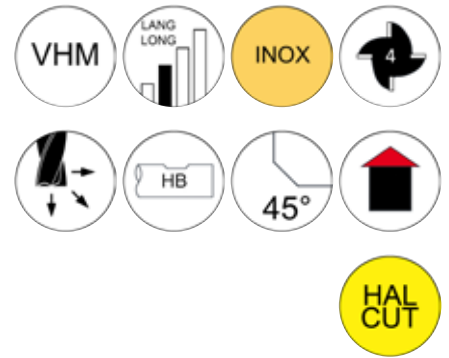

Artikel-Nr. Article-No.	D1	D2	D3	L2	L3	L1	Z	EF	Preis/Euro Price/Euro
FV-HPC206.0300L.VA	3	6	2,8	8	18	57	4	0,10	34,01 €
FV-HPC206.0400L.VA	4	6	3,6	11	21	57	4	0,13	34,01 €
FV-HPC206.0500L.VA	5	6	4,6	13	21	57	4	0,20	34,01 €
FV-HPC206.0600L.VA	6	6	5,5	13	21	57	4	0,20	34,01 €
FV-HPC206.0700L.VA	7	8	6,5	16	24	63	4	0,20	45,55 €
FV-HPC206.0800L.VA	8	8	7,5	19	27	63	4	0,20	45,55 €
FV-HPC206.0900L.VA	9	10	8,5	20	29	72	4	0,20	60,25 €
FV-HPC206.1000L.VA	10	10	9,5	22	32	72	4	0,20	62,76 €
FV-HPC206.1100L.VA	11	12	10,5	24	35	83	4	0,30	81,89 €
FV-HPC206.1200L.VA	12	12	11,5	26	38	83	4	0,30	85,31 €
FV-HPC206.1400L.VA	14	14	13,5	30	42	83	4	0,30	107,68 €
FV-HPC206.1600L.VA	16	16	15,5	32	44	92	4	0,30	130,43 €
FV-HPC206.2000L.VA	20	20	19,5	38	54	104	4	0,40	192,44 €

FRÄSWERKZEUGE





FV-HPC206

VHM-HPC-HOCHLEISTUNGSFRÄSER "ECOLIX-INOX" LANG

MATERIALBESCHREIBUNG

		Vc m/min von/bis		fz		fz		fz		fz		fz		fz	
				Ø 3,0-4,0 von/bis	Ø 4,0-6,0 von/bis	Ø 6,0-10,0 von/bis	Ø 10,0-16,0 von/bis	Ø 16,0-20,0 von/bis	Ø 20,0-25,0 von/bis						
P.1	<500N/mm	220	240	0,012	0,020	0,020	0,035	0,035	0,075	0,075	0,100	0,100	0,120	0,012	0,130
P.2	<650N/mm	200	220	0,012	0,020	0,020	0,035	0,035	0,075	0,075	0,100	0,100	0,120	0,012	0,130
P.3	<800N/mm	165	185	0,012	0,020	0,020	0,035	0,035	0,075	0,075	0,100	0,100	0,120	0,012	0,130
P.4	<1000N/mm														
P.5	<1400N/mm														
P.6	Einsatz-ST <1000N/mm														
P.7	Nitrier-ST <1000N/mm														
P.8	Vergütung-ST 850N/mm														
P.9	Werkzeug-ST 1000N/mm														
M.1	VA <750N/mm	85	100	0,012	0,020	0,020	0,035	0,045	0,075	0,075	0,100	0,100	0,120	0,012	0,130
M.2	VA >750N/mm	45	65	0,009	0,015	0,015	0,025	0,025	0,052	0,052	0,070	0,070	0,084	0,084	0,091
K.1	Gusseisen <200HB	180	200	0,012	0,020	0,020	0,035	0,045	0,075	0,075	0,100	0,100	0,120	0,012	0,130
K.2	Temperguss	130	150	0,012	0,020	0,020	0,035	0,045	0,075	0,075	0,100	0,100	0,120	0,012	0,130
K.3	Gusseisen mit Kugelgrafit	130	150	0,012	0,020	0,020	0,035	0,045	0,075	0,075	0,100	0,100	0,120	0,012	0,130
N.1	AL <5%														
N.2	AL <10%														
N.3	AL >10%														
N.4	Ms, Cu, Bronze, Rotguss														
N.5	Duro-Thermoplast														
N.6	Grafit, GFK														
S.1	Titan	55	65	0,009	0,015	0,015	0,025	0,025	0,052	0,052	0,070	0,070	0,084	0,084	0,091
S.2	Nickel	55	65	0,009	0,015	0,015	0,025	0,025	0,052	0,052	0,070	0,070	0,084	0,084	0,091
H.1	45-52 HRC														
H.2	52-60 HRC														
H.3	60-65 HRC														



FV-HPC510

VHM-HPC-HOCHLEISTUNGSFRÄSER "INOXIX" KURZ

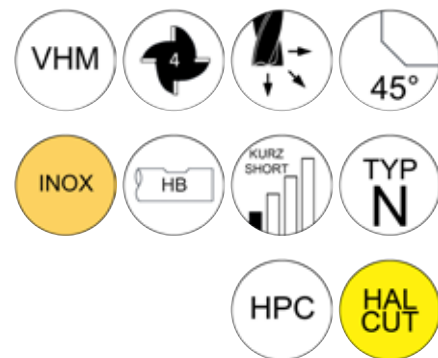

Artikel-Nr. Article-No.	D1	D2	L2	L1	Z	EF	Preis/Euro Price/Euro
FV-HPC510.0300K.UN	3	6	6	54	4	0,06	46,35 €
FV-HPC510.0400K.UN	4	6	8	54	4	0,08	46,35 €
FV-HPC510.0500K.UN	5	6	9	54	4	0,10	46,35 €
FV-HPC510.0600K.UN	6	6	10	54	4	0,13	46,35 €
FV-HPC510.0800K.UN	8	8	12	58	4	0,15	60,89 €
FV-HPC510.1000K.UN	10	10	14	66	4	0,20	78,00 €
FV-HPC510.1200K.UN	12	12	16	73	4	0,25	103,51 €
FV-HPC510.1600K.UN	16	16	22	82	4	0,35	180,63 €
FV-HPC510.2000K.UN	20	20	26	92	4	0,40	251,32 €





FV-HPC510

VHM-HPG-HOCHLEISTUNGSFRÄSER "INOXIX" KURZ

MATERIALBESCHREIBUNG

		Vc m/min von/bis		fz		fz		fz		fz		fz		fz	
				Ø 3,0-4,0 von/bis	Ø 4,0-6,0 von/bis	Ø 6,0-10,0 von/bis	Ø 10,0-16,0 von/bis	Ø 16,0-20,0 von/bis	Ø 20,0-25,0 von/bis						
P.1	<500N/mm	220	240	0,012	0,020	0,020	0,035	0,035	0,075	0,075	0,100	0,100	0,120	0,012	0,130
P.2	<650N/mm	200	220	0,012	0,020	0,020	0,035	0,035	0,075	0,075	0,100	0,100	0,120	0,012	0,130
P.3	<800N/mm	165	185	0,012	0,020	0,020	0,035	0,035	0,075	0,075	0,100	0,100	0,120	0,012	0,130
P.4	<1000N/mm														
P.5	<1400N/mm														
P.6	Einsatz-ST <1000N/mm														
P.7	Nitrier-ST <1000N/mm														
P.8	Vergütung-ST 850N/mm														
P.9	Werkzeug-ST 1000N/mm														
M.1	VA <750N/mm	85	100	0,012	0,020	0,020	0,035	0,045	0,075	0,075	0,100	0,100	0,120	0,012	0,130
M.2	VA >750N/mm	45	65	0,009	0,015	0,015	0,025	0,025	0,052	0,052	0,070	0,070	0,084	0,084	0,091
K.1	Gusseisen <200HB	180	200	0,012	0,020	0,020	0,035	0,045	0,075	0,075	0,100	0,100	0,120	0,012	0,130
K.2	Temperguss	130	150	0,012	0,020	0,020	0,035	0,045	0,075	0,075	0,100	0,100	0,120	0,012	0,130
K.3	Gusseisen mit Kugelgraphit	130	150	0,012	0,020	0,020	0,035	0,045	0,075	0,075	0,100	0,100	0,120	0,012	0,130
N.1	AL <5%														
N.2	AL <10%														
N.3	AL >10%														
N.4	Ms, Cu, Bronze, Rotguss														
N.5	Duro-Thermoplast														
N.6	Grafit, GFK														
S.1	Titan	55	65	0,009	0,015	0,015	0,025	0,025	0,052	0,052	0,070	0,070	0,084	0,084	0,091
S.2	Nickel	55	65	0,009	0,015	0,015	0,025	0,025	0,052	0,052	0,070	0,070	0,084	0,084	0,091
H.1	45-52 HRC														
H.2	52-60 HRC														
H.3	60-65 HRC														



FV-HPC511

VHM-HPC-HOCHLEISTUNGSFRÄSER "INOXIX" LANG

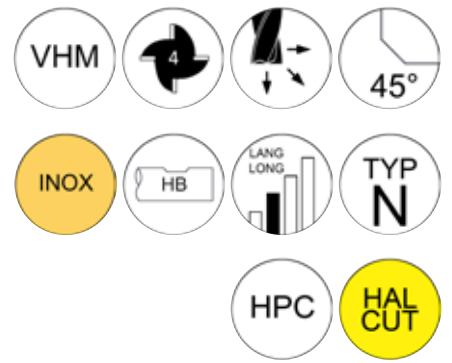

Artikel-Nr. Article-No.	D1	D2	D3	L2	L3	L1	Z	EF	Preis/Euro Price/Euro
FV-HPC511.0300L.UN	3	6	2,8	8	18	57,0	4	0,06	48,98 €
FV-HPC511.0400L.UN	4	6	3,6	11	21	57,0	4	0,08	48,98 €
FV-HPC511.0500L.UN	5	6	4,6	13	21	57,0	4	0,10	48,98 €
FV-HPC511.0600L.UN	6	6	5,5	13	21	57,0	4	0,13	48,98 €
FV-HPC511.0800L.UN	8	8	7,5	19	27	63,0	4	0,15	64,82 €
FV-HPC511.1000L.UN	10	10	9,5	22	32	72,0	4	0,20	90,92 €
FV-HPC511.1200L.UN	12	12	11,5	26	38	83,0	4	0,25	119,03 €
FV-HPC511.1600L.UN	16	16	15,5	32	44	92,0	4	0,35	209,82 €
FV-HPC511.2000L.UN	20	20	19,5	38	54	104,0	4	0,40	285,64 €





FV-HPC511

VHM-HPC-HOCHLEISTUNGSFRÄSER "INOXIX" LANG

MATERIALBESCHREIBUNG

		Vc m/min von/bis		fz		fz		fz		fz		fz		fz	
				Ø 3,0-4,0 von/bis	Ø 4,0-6,0 von/bis	Ø 6,0-10,0 von/bis	Ø 10,0-16,0 von/bis	Ø 16,0-20,0 von/bis	Ø 20,0-25,0 von/bis						
P.1	<500N/mm	220	240	0,012	0,020	0,020	0,035	0,035	0,075	0,075	0,100	0,100	0,120	0,012	0,130
P.2	<650N/mm	200	220	0,012	0,020	0,020	0,035	0,035	0,075	0,075	0,100	0,100	0,120	0,012	0,130
P.3	<800N/mm	165	185	0,012	0,020	0,020	0,035	0,035	0,075	0,075	0,100	0,100	0,120	0,012	0,130
P.4	<1000N/mm														
P.5	<1400N/mm														
P.6	Einsatz-ST <1000N/mm														
P.7	Nitrier-ST <1000N/mm														
P.8	Vergütung-ST 850N/mm														
P.9	Werkzeug-ST 1000N/mm														
M.1	VA <750N/mm	85	100	0,012	0,020	0,020	0,035	0,045	0,075	0,075	0,100	0,100	0,120	0,012	0,130
M.2	VA >750N/mm	45	65	0,009	0,015	0,015	0,025	0,025	0,052	0,052	0,070	0,070	0,084	0,084	0,091
K.1	Gusseisen <200HB	180	200	0,012	0,020	0,020	0,035	0,045	0,075	0,075	0,100	0,100	0,120	0,012	0,130
K.2	Temperguss	130	150	0,012	0,020	0,020	0,035	0,045	0,075	0,075	0,100	0,100	0,120	0,012	0,130
K.3	Gusseisen mit Kugelgraphit	130	150	0,012	0,020	0,020	0,035	0,045	0,075	0,075	0,100	0,100	0,120	0,012	0,130
N.1	AL <5%														
N.2	AL <10%														
N.3	AL >10%														
N.4	Ms, Cu, Bronze, Rotguss														
N.5	Duro-Thermoplast														
N.6	Grafit, GFK														
S.1	Titan	55	65	0,009	0,015	0,015	0,025	0,025	0,052	0,052	0,070	0,070	0,084	0,084	0,091
S.2	Nickel	55	65	0,009	0,015	0,015	0,025	0,025	0,052	0,052	0,070	0,070	0,084	0,084	0,091
H.1	45-52 HRC														
H.2	52-60 HRC														
H.3	60-65 HRC														



FV-MTC221

VHM-MTC-INOX-HOCHLEISTUNGSSCHRUPPFRÄSER TYP NRF

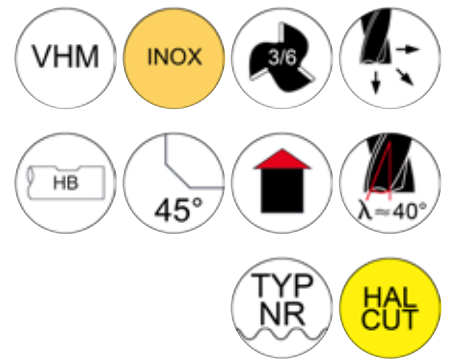

Artikel-Nr. Article-No.	D1	D2	D3	L2	L3	L1	Z	EF	Preis/Euro Price/Euro
FV-MTC221.0400L.VA	4	6	3,8	11	18	57	3	0,15	72,18 €
FV-MTC221.0500L.VA	5	6	4,7	13	20	57	4	0,15	72,18 €
FV-MTC221.0600L.VA	6	6	5,5	16	20	57	4	0,15	74,49 €
FV-MTC221.0700L.VA	7	8	6,5	16	25	63	4	0,15	79,08 €
FV-MTC221.0800L.VA	8	8	7,5	16	26	63	4	0,15	85,98 €
FV-MTC221.0900L.VA	9	10	8,5	19	30	72	4	0,20	86,46 €
FV-MTC221.1000L.VA	10	10	9,5	22	31	72	4	0,20	95,64 €
FV-MTC221.1200L.VA	12	12	11,5	26	37	83	4	0,20	109,43 €
FV-MTC221.1400L.VA	14	14	13,5	26	42	83	5	0,20	145,05 €
FV-MTC221.1600L.VA	16	16	15,5	32	51	100	5	0,25	189,27 €
FV-MTC221.2000L.VA	20	20	19,2	38	59	110	6	0,25	295,37 €
FV-MTC221.2500L.VA	25	25	24,0	45	65	121	6	0,30	470,89 €



MATERIALBESCHREIBUNG

		Vc m/min von/bis		fz		fz		fz		fz	
				Ø 4,0-6,0 von/bis		Ø 6,0-10,0 von/bis		Ø 10,0-16,0 von/bis		Ø 16,0-20,0 von/bis	
P.1	<500N/mm	215	235	0,020	0,035	0,035	0,075	0,075	0,100	0,100	0,120
P.2	<650N/mm	195	215	0,020	0,035	0,035	0,075	0,075	0,100	0,100	0,120
P.3	<800N/mm	160	180	0,020	0,035	0,035	0,075	0,075	0,100	0,100	0,120
P.4	<1000N/mm	135	155	0,015	0,025	0,025	0,052	0,052	0,070	0,070	0,084
P.5	<1400N/mm										
P.6	Einsatz-ST <1000N/mm	125	145	0,015	0,025	0,025	0,052	0,052	0,070	0,070	0,084
P.7	Nitrier-ST <1000N/mm	125	145	0,015	0,025	0,025	0,052	0,052	0,070	0,070	0,084
P.8	Vergütung-ST 850N/mm	150	170	0,020	0,035	0,035	0,075	0,075	0,100	0,100	0,120
P.9	Werkzeug-ST 1000N/mm										
M.1	VA <750N/mm	85	105	0,020	0,035	0,035	0,075	0,075	0,100	0,100	0,120
M.2	VA >750N/mm	60	80	0,015	0,025	0,025	0,052	0,052	0,070	0,070	0,084
K.1	Gusseisen <200HB	160	180	0,020	0,035	0,035	0,075	0,075	0,100	0,100	0,120
K.2	Temperguss	90	110	0,020	0,035	0,035	0,075	0,075	0,100	0,100	0,120
K.3	Gusseisen mit Kugelgrafit	90	110	0,020	0,035	0,035	0,075	0,075	0,100	0,100	0,120
N.1	AL <5%										
N.2	AL <10%										
N.3	AL >10%										
N.4	Ms, Cu, Bronze, Rotguss										
N.5	Duro-Thermoplast										
N.6	Grafit, GFK										
S.1	Titan										
S.2	Nickel										
H.1	45-52 HRC										
H.2	52-60 HRC										
H.3	60-65 HRC										



FV-FIN231

VHM-TSC-UNI-HOCHLEISTUNGSFRÄSER

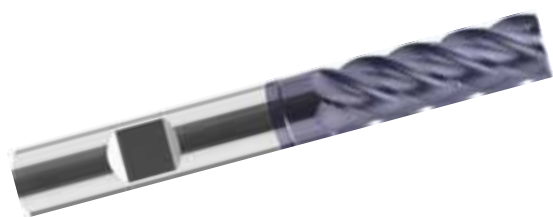
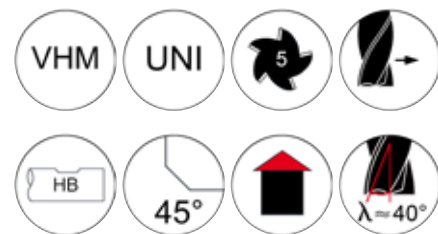

Artikel-Nr. Article-No.	D1	D2	L2	L3	L1	Z	EF	Preis/Euro Price/Euro
FV-FIN231.0600L.VA	6	6	18	25	62	5	0,10	68,23 €
FV-FIN231.0800L.VA	8	8	24	30	68	5	0,15	87,78 €
FV-FIN231.1000L.VA	10	10	30	35	80	5	0,20	113,82 €
FV-FIN231.1200L.VA	12	12	36	45	93	5	0,20	141,87 €
FV-FIN231.1600L.VA	16	16	48	55	108	5	0,30	231,75 €
FV-FIN231.2000L.VA	20	20	60	70	126	5	0,40	359,68 €



FV-FIN231

VHM-TSC-UNI-HOCHLEISTUNGSFRÄSER

MATERIALBESCHREIBUNG

		Vc m/min von/bis		fz		fz		fz		fz	
				Ø 6,0	Ø 8,0	Ø 10,0	Ø 12,0	Ø 16,0	Ø 16,0		
P.1	<500N/mm	280	300	0,05	00,6	0,072	0,09	0,108	0,144	0,18	
P.2	<650N/mm	280	300	0,05	0,06	0,072	0,09	0,108	0,144	0,18	
P.3	<800N/mm	260	280	0,05	0,06	0,072	0,09	0,108	0,144	0,18	
P.4	<1000N/mm	240	260	0,045	0,050	0,056	0,07	0,084	0,112	0,14	
P.5	<1400N/mm	160	180	0,03	0,035	0,056	0,07	0,084	0,112	0,14	
P.6	Einsatz-ST <1000N/mm	240	260	0,045	0,05	0,056	0,07	0,084	0,112	0,14	
P.7	Nitrier-ST <1000N/mm	220	240	0,045	0,05	0,056	0,07	0,084	0,112	0,14	
P.8	Vergütung-ST 850N/mm	240	260	0,045	0,05	0,056	0,07	0,084	0,112	0,14	
P.9	Werkzeug-ST 1000N/mm	240	260	0,045	0,05	0,056	0,07	0,084	0,112	0,14	
M.1	VA <750N/mm	120	140	0,03	0,035	0,04	0,05	0,06	0,08	0,1	
M.2	VA >750N/mm	80	100	0,024	0,03	0,032	0,04	0,048	0,064	0,08	
K.1	Gusseisen <200HB	240	260	0,05	0,06	0,072	0,09	0,108	0,144	0,18	
K.2	Temperguss	200	240	0,42	0,45	0,056	0,07	0,084	0,112	0,14	
K.3	Gusseisen mit Kugelgrafit	180	220	0,03	0,035	0,04	0,05	0,06	0,08	0,1	
N.1	AL <5%	280	320	0,06	0,07	0,088	0,11	0,132	0,176	0,22	
N.2	AL <10%										
N.3	AL >10%										
N.4	Ms, Cu, Bronze, Rotguss	150	200	0,04	0,05	0,056	0,07	0,084	0,112	0,14	
N.5	Duro-Thermoplast										
N.6	Grafit, GFK										
S.1	Titan	80	120	0,03	0,035	0,04	0,05	0,06	0,08	0,1	
S.2	Nickel	40	80	0,024	0,028	0,032	0,04	0,048	0,064	0,08	
H.1	45-52 HRC										
H.2	52-60 HRC										
H.3	60-65 HRC										



FV-KON362

VHM-ALU-EINZAHNFRÄSER

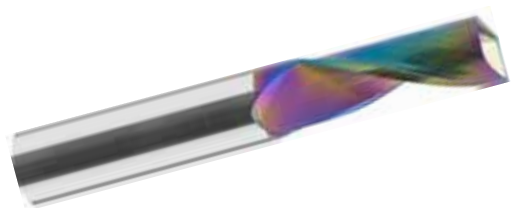

Artikel-Nr. Article-No.	D1	D2	L2	L1	Z	Preis/Euro Price/Euro
FV-KON362.0100K.AL	1	3	4	50	1	38,75 €
FV-KON362.0150K.AL	1,5	3	6	50	1	39,31 €
FV-KON362.0200K.AL	2	3	8	50	1	41,25 €
FV-KON362.0300K.AL	3	3	12	50	1	43,47 €
FV-KON362.0400K.AL	4	4	15	60	1	48,56 €
FV-KON362.0500K.AL	5	5	17	60	1	56,39 €
FV-KON362.0600K.AL	6	6	20	65	1	59,40 €
FV-KON362.0800K.AL	8	8	22	65	1	82,79 €
FV-KON362.1000K.AL	10	10	25	75	1	122,72 €
FV-KON362.1200K.AL	12	12	30	80	1	169,72 €



FV-KON362

VHM-ALU-EINZAHNFRÄSER

MATERIALBESCHREIBUNG

		Vc m/min von/bis		fz		fz		fz		fz		fz	
				Ø 1,0-6,0 von/bis	Ø 6,0-10,0 von/bis	Ø 10,0-16,0 von/bis	Ø 16,0-20,0 von/bis	Ø 20,0-25,0 von/bis					
P.1	<500N/mm												
P.2	<650N/mm												
P.3	<800N/mm												
P.4	<1000N/mm												
P.5	<1400N/mm												
P.6	Einsatz-ST <1000N/mm												
P.7	Nitrier-ST <1000N/mm												
P.8	Vergütung-ST 850N/mm												
P.9	Werkzeug-ST 1000N/mm												
M.1	VA <750N/mm												
M.2	VA >750N/mm												
K.1	Gusseisen <200HB												
K.2	Temperguss												
K.3	Gusseisen mit Kugelgrafit												
N.1	AL <5%	280	330	0,005	0,018	0,018	0,030	0,030	0,065	0,065	0,100	0,100	0,130
N.2	AL <10%	240	280	0,005	0,018	0,018	0,030	0,030	0,065	0,065	0,100	0,100	0,130
N.3	AL >10%	200	250	0,005	0,018	0,018	0,030	0,030	0,065	0,065	0,100	0,100	0,130
N.4	Ms, Cu, Bronze, Rotguss	130	180	0,005	0,018	0,018	0,030	0,030	0,065	0,065	0,100	0,100	0,130
N.5	Duro-Thermoplast	130	180	0,005	0,018	0,018	0,030	0,030	0,065	0,065	0,100	0,100	0,130
N.6	Grafit, GFK												
S.1	Titan												
S.2	Nickel												
H.1	45-52 HRC												
H.2	52-60 HRC												
H.3	60-65 HRC												



FV-KON360

VHM-ALU-SCHAFTFRÄSER

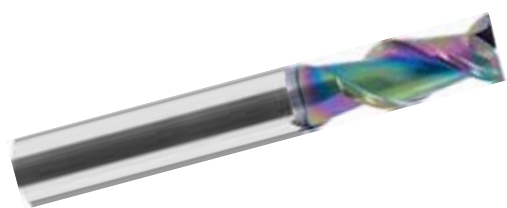
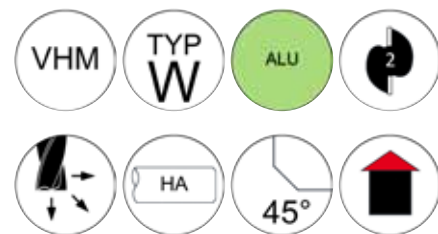

Artikel-Nr. Article-No.	D1	D2	L2	L3	L1	Z	Preis/Euro Price/Euro
FV-KON360.0100L.AL	1	3	3	8	50	2	64,37 €
FV-KON360.0150L.AL	1,5	3	4	10	50	2	56,48 €
FV-KON360.0200L.AL	2	3	6	12	50	2	56,48 €
FV-KON360.0300L.AL	3	3	8	18	57	2	52,33 €
FV-KON360.0400L.AL	4	4	11	18	57	2	52,33 €
FV-KON360.0500L.AL	5	5	13	20	57	2	52,33 €
FV-KON360.0600L.AL	6	6	13	20	57	2	52,62 €
FV-KON360.0800L.AL	8	8	19	26	63	2	59,40 €
FV-KON360.1000L.AL	10	10	22	29	72	2	82,27 €
FV-KON360.1200L.AL	12	12	26	36	83	2	126,91 €
FV-KON360.1400L.AL	14	14	26	36	83	2	183,83 €
FV-KON360.1600L.AL	16	16	32	42	92	2	200,42 €
FV-KON360.1800L.AL	18	18	32	45	92	2	265,89 €
FV-KON360.2000L.AL	2	20	38	52	104	2	289,85 €



FV-KON360

VHM-ALU-SCHAFTFRÄSER

MATERIALBESCHREIBUNG

		Vc m/min von/bis		fz		fz		fz		fz		fz	
				Ø 1,0-6,0 von/bis	Ø 6,0-10,0 von/bis	Ø 10,0-16,0 von/bis	Ø 16,0-20,0 von/bis	Ø 20,0-25,0 von/bis					
P.1	<500N/mm												
P.2	<650N/mm												
P.3	<800N/mm												
P.4	<1000N/mm												
P.5	<1400N/mm												
P.6	Einsatz-ST <1000N/mm												
P.7	Nitrier-ST <1000N/mm												
P.8	Vergütung-ST 850N/mm												
P.9	Werkzeug-ST 1000N/mm												
M.1	VA <750N/mm												
M.2	VA >750N/mm												
K.1	Gusseisen <200HB												
K.2	Temperguss												
K.3	Gusseisen mit Kugelgraphit												
N.1	AL <5%	750	850	0,015	0,035	0,035	0,055	0,055	0,080	0,080	0,110	0,110	0,130
N.2	AL <10%	550	650	0,015	0,035	0,035	0,055	0,055	0,080	0,080	0,110	0,110	0,130
N.3	AL >10%	490	550	0,015	0,035	0,035	0,055	0,055	0,080	0,080	0,110	0,110	0,130
N.4	Ms, Cu, Bronze, Rotguss	280	320	0,015	0,035	0,035	0,055	0,055	0,080	0,080	0,110	0,110	0,130
N.5	Duro-Thermoplast	550	650	0,015	0,035	0,035	0,055	0,055	0,080	0,080	0,110	0,110	0,130
N.6	Graphit, GFK												
S.1	Titan												
S.2	Nickel												
H.1	45-52 HRC												
H.2	52-60 HRC												
H.3	60-65 HRC												



FV-HPC361

VHM-ALU-HPC-HOCHLEISTUNGSFRÄSER "ALUNIX"

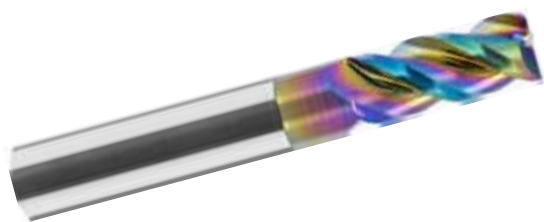
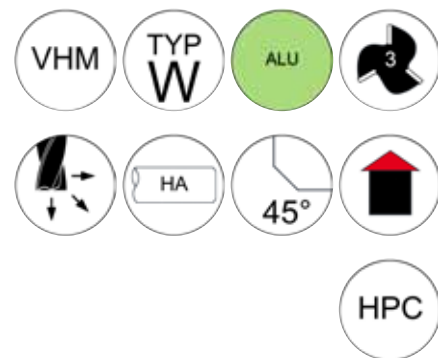

Artikel-Nr. Article-No.	D1	D2	D3	L2	L3	L1	Z	EF	Preis/Euro Price/Euro
FV-HPC361.0300L.AL	3	6	2,9	12	16	57	3	0,10	42,25 €
FV-HPC361.0400L.AL	4	6	3,9	12	18	57	3	0,10	42,25 €
FV-HPC361.0500L.AL	5	6	4,9	15	18	57	3	0,10	42,25 €
FV-HPC361.0600L.AL	6	6	5,8	15	21	57	3	0,10	42,25 €
FV-HPC361.0800L.AL	8	8	7,8	22	28	64	3	0,10	47,02 €
FV-HPC361.1000L.AL	10	10	9,7	25	33	73	3	0,20	72,87 €
FV-HPC361.1200L.AL	12	12	11,7	28	39	84	3	0,20	104,69 €
FV-HPC361.1400L.AL	14	14	13,7	32	42	89	3	0,20	160,77 €
FV-HPC361.1600L.AL	16	16	15,7	35	45	93	3	0,20	175,25 €
FV-HPC361.2000L.AL	20	20	19,5	41	52	104	3	0,20	271,55 €



ALUNIX



FV-HPC361

VHM-ALU-HPC-HOCHLEISTUNGSFRÄSER "ALUNIX"

MATERIALBESCHREIBUNG

		Vc m/min von/bis		fz		fz		fz		fz		fz	
				Ø 1,0-6,0 von/bis		Ø 6,0-10,0 von/bis		Ø 10,0-16,0 von/bis		Ø 16,0-20,0 von/bis		Ø 20,0-25,0 von/bis	
P.1	<500N/mm												
P.2	<650N/mm												
P.3	<800N/mm												
P.4	<1000N/mm												
P.5	<1400N/mm												
P.6	Einsatz-ST <1000N/mm												
P.7	Nitrier-ST <1000N/mm												
P.8	Vergütung-ST 850N/mm												
P.9	Werkzeug-ST 1000N/mm												
M.1	VA <750N/mm												
M.2	VA >750N/mm												
K.1	Gusseisen <200HB												
K.2	Temperguss												
K.3	Gusseisen mit Kugelgrafit												
N.1	AL <5%	380	430	0,025	0,055	0,055	0,065	0,065	0,085	0,085	0,110	0,110	0,130
N.2	AL <10%	330	380	0,025	0,055	0,055	0,065	0,065	0,085	0,085	0,110	0,110	0,130
N.3	AL >10%	200	250	0,025	0,055	0,055	0,065	0,065	0,085	0,085	0,110	0,110	0,130
N.4	Ms, Cu, Bronze, Rotguss	140	180	0,020	0,035	0,035	0,050	0,050	0,075	0,075	0,090	0,090	0,120
N.5	Duro-Thermoplast	430	470	0,025	0,055	0,055	0,065	0,065	0,085	0,085	0,110	0,110	0,130
N.6	Grafit, GFK												
S.1	Titan												
S.2	Nickel												
H.1	45-52 HRC												
H.2	52-60 HRC												
H.3	60-65 HRC												



FV-MTC365

VHM-MTC-ALU-HOCHLEISTUNGSSCHRUPPFRÄSER "ALU-SCHRUPPIX"

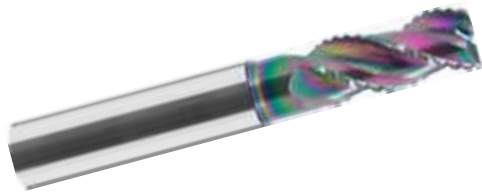
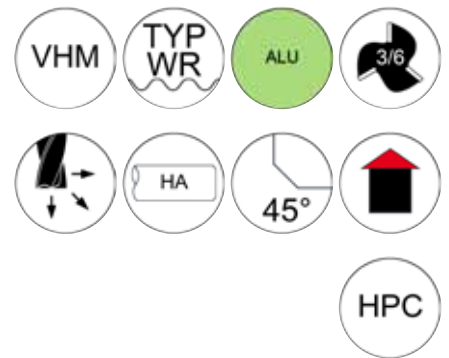

Artikel-Nr. Article-No.	D1	D2	D3	L2	L3	L1	Z	EF	Preis/Euro Price/Euro
FV-MTC365.0600L.AL	6	6	5,7	14	20	57	3	0,20	86,11 €
FV-MTC365.0800L.AL	8	8	7,4	21	26	63	3	0,25	99,52 €
FV-MTC365.1000L.AL	10	10	9,5	23	31	72	3	0,30	121,69 €
FV-MTC365.1200L.AL	12	12	11,0	27	37	83	3	0,35	149,54 €
FV-MTC365.1600L.AL	16	16	15,0	36	43	92	3	0,40	205,22 €
FV-MTC365.2000L.AL	20	20	19,0	41	52	104	3	0,40	288,67 €





MATERIALBESCHREIBUNG

		Vc m/min von/bis		fz		fz		fz		fz		fz	
				Ø 1,0-6,0 von/bis	Ø 6,0-10,0 von/bis	Ø 10,0-16,0 von/bis	Ø 16,0-20,0 von/bis	Ø 20,0-25,0 von/bis					
P.1	<500N/mm												
P.2	<650N/mm												
P.3	<800N/mm												
P.4	<1000N/mm												
P.5	<1400N/mm												
P.6	Einsatz-ST <1000N/mm												
P.7	Nitrier-ST <1000N/mm												
P.8	Vergütung-ST 850N/mm												
P.9	Werkzeug-ST 1000N/mm												
M.1	VA <750N/mm												
M.2	VA >750N/mm												
K.1	Gusseisen <200HB												
K.2	Temperguss												
K.3	Gusseisen mit Kugelgrafit												
N.1	AL <5%	380	430	0,025	0,055	0,055	0,065	0,065	0,085	0,085	0,110	0,110	0,130
N.2	AL <10%	330	380	0,025	0,055	0,055	0,065	0,065	0,085	0,085	0,110	0,110	0,130
N.3	AL >10%	200	250	0,025	0,055	0,055	0,065	0,065	0,085	0,085	0,110	0,110	0,130
N.4	Ms, Cu, Bronze, Rotguss	140	180	0,020	0,035	0,035	0,050	0,050	0,075	0,075	0,090	0,090	0,120
N.5	Duro-Thermoplast	430	470	0,025	0,055	0,055	0,065	0,065	0,085	0,085	0,110	0,110	0,130
N.6	Grafit, GFK												
S.1	Titan												
S.2	Nickel												
H.1	45-52 HRC												
H.2	52-60 HRC												
H.3	60-65 HRC												



FV-MTC375

VHM-MTC-ALU-HOCHLEISTUNGSFRÄSER "IK-ALU-SCHRUPPIX" MIT INNENKÜHLUNG



Artikel-Nr. Article-No.	D1	D2	D3	L2	L3	L1	Z	EF	Preis/Euro Price/Euro
FV-MTC375.0600L.AL	6	6	5,7	14	20	57	3	0,20	106,65 €
FV-MTC375.0800L.AL	8	8	7,4	21	26	63	3	0,25	123,27 €
FV-MTC375.1000L.AL	10	10	9,5	23	31	72	3	0,30	150,70 €
FV-MTC375.1200L.AL	12	12	11,0	27	37	83	3	0,35	185,20 €
FV-MTC375.1600L.AL	16	16	15,0	36	43	92	3	0,40	254,15 €
FV-MTC375.2000L.AL	20	20	19,0	41	52	104	3	0,40	357,50 €





MATERIALBESCHREIBUNG

		Vc m/min von/bis		fz		fz		fz		fz		fz	
				Ø 1,0-6,0 von/bis		Ø 6,0-10,0 von/bis		Ø 10,0-16,0 von/bis		Ø 16,0-20,0 von/bis		Ø 20,0-25,0 von/bis	
P.1	<500N/mm												
P.2	<650N/mm												
P.3	<800N/mm												
P.4	<1000N/mm												
P.5	<1400N/mm												
P.6	Einsatz-ST <1000N/mm												
P.7	Nitrier-ST <1000N/mm												
P.8	Vergütung-ST 850N/mm												
P.9	Werkzeug-ST 1000N/mm												
M.1	VA <750N/mm												
M.2	VA >750N/mm												
K.1	Gusseisen <200HB												
K.2	Temperguss												
K.3	Gusseisen mit Kugelgrafit												
N.1	AL <5%	380	430	0,025	0,055	0,055	0,065	0,065	0,085	0,085	0,110	0,110	0,130
N.2	AL <10%	330	380	0,025	0,055	0,055	0,065	0,065	0,085	0,085	0,110	0,110	0,130
N.3	AL >10%	200	250	0,025	0,055	0,055	0,065	0,065	0,085	0,085	0,110	0,110	0,130
N.4	Ms, Cu, Bronze, Rotguss	140	180	0,020	0,035	0,035	0,050	0,050	0,075	0,075	0,090	0,090	0,120
N.5	Duro-Thermoplast	430	470	0,025	0,055	0,055	0,065	0,065	0,085	0,085	0,110	0,110	0,130
N.6	Grafit, GFK												
S.1	Titan												
S.2	Nickel												
H.1	45-52 HRC												
H.2	52-60 HRC												
H.3	60-65 HRC												



9 8LAIG 0







HALLAS
TOOLS

KREISSÄGEBLÄTTER



BESCHREIBUNG WERKZEUGE

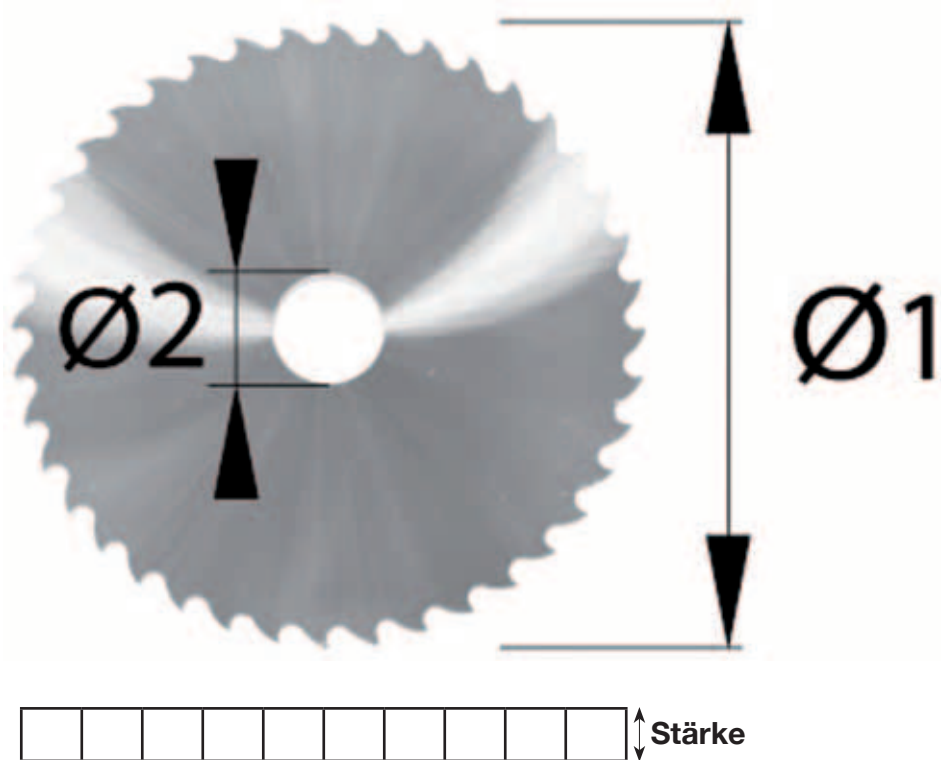
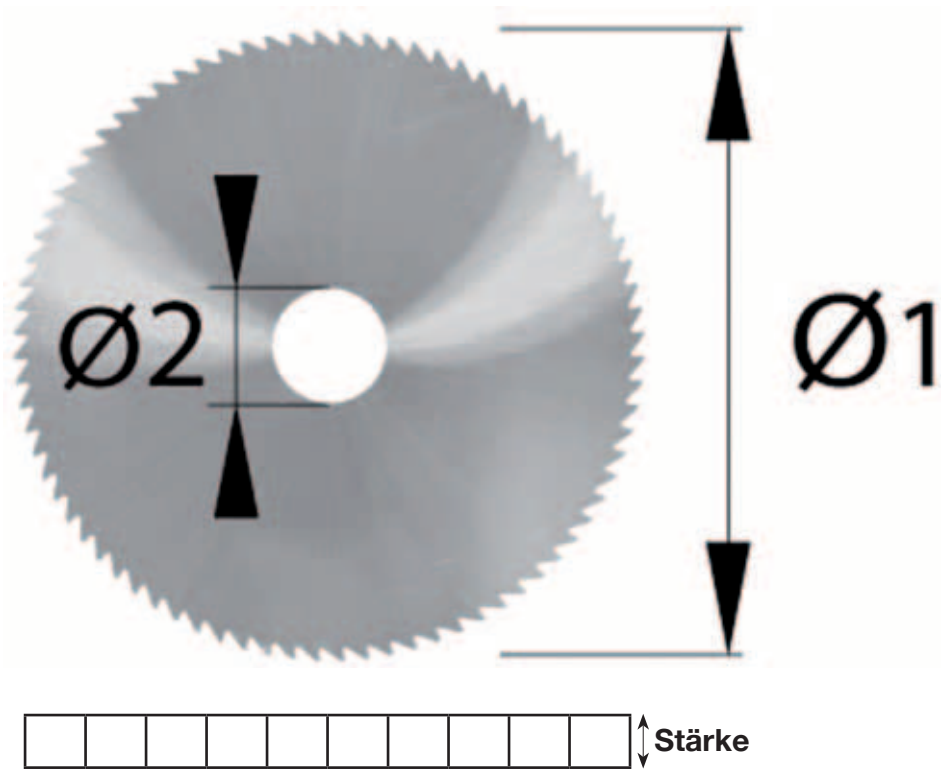

INHALTSVERZEICHNIS KREISSÄGEBLÄTTER



Artikel	KS-VF10001	KS-VG20001	KS-HF10001	KS-HG20001	KS-HG30001
Substrat	VHM	VHM	HSS	HSS	HSS
Drm.-Bereich	15-200	15-200	20-315	50-315	50-315
DIN	1837	1838	1837	1838	1838
Form	A	B	A	B	C
Seite	172	184	196	203	208
P.1	●	●	●	●	●
P.2	●	●	●	●	●
P.3	●	●	●	●	●
P.4	●	●	●	●	●
P.5	●	●	●	●	●
P.6	●	●	●	●	●
P.7	●	●	●	●	●
P.8	●	●	●	●	●
P.9	●	●	●	●	●
M.1	●	●	●	●	●
M.2	●	●	●	●	●
K.1	●	●	●	●	●
K.2	●	●	●	●	●
K.3					
N.1	●	●	●	●	●
N.2	●	●	●	●	●
N.3	●	●	●	●	●
N.4	●	●	●	●	●
N.5	●	●	●	●	●
N.6					
S.1					
S.1					
H.1					
H.2					
H.3					



KS-VF10001

VHM-KREISSÄGEBLATT, FEINVERZAHNT



Ø 15MM

Artikel-Nr. Article-No.	Durchmesser	Bohrung	Stärke	Zähnezahl	Preis/Euro Price/Euro
KS-VF10001.0015U.02	15	5	0,20	64	18,15 €
KS-VF10001.0015U.025	15	5	0,25	64	18,15 €
KS-VF10001.0015U.03	15	5	0,30	64	18,15 €
KS-VF10001.0015U.035	15	5	0,35	64	18,15 €
KS-VF10001.0015U.04	15	5	0,40	64	18,15 €
KS-VF10001.0015U.05	15	5	0,50	48	18,15 €
KS-VF10001.0015U.06	15	5	0,60	48	18,15 €
KS-VF10001.0015U.07	15	5	0,70	48	21,68 €
KS-VF10001.0015U.08	15	5	0,80	40	21,68 €
KS-VF10001.0015U.09	15	5	0,90	40	22,33 €
KS-VF10001.0015U.10	15	5	1,00	40	23,12 €
KS-VF10001.0015U.11	15	5	1,10	40	24,15 €
KS-VF10001.0015U.12	15	5	1,20	40	24,15 €
KS-VF10001.0015U.13	15	5	1,30	40	24,15 €
KS-VF10001.0015U.14	15	5	1,40	40	24,15 €
KS-VF10001.0015U.15	15	5	1,50	40	24,74 €
KS-VF10001.0015U.16	15	5	1,60	40	25,99 €
KS-VF10001.0015U.17	15	5	1,70	40	28,26 €
KS-VF10001.0015U.18	15	5	1,80	40	28,26 €
KS-VF10001.0015U.19	15	5	1,90	40	29,53 €
KS-VF10001.0015U.20	15	5	2,00	40	29,05 €
KS-VF10001.0015U.25	15	5	2,50	40	39,28 €
KS-VF10001.0015U.30	15	5	3,00	40	44,52 €
KS-VF10001.0015U.35	15	5	3,50	40	50,23 €
KS-VF10001.0015U.40	15	5	4,00	40	62,05 €
KS-VF10001.0015U.45	15	5	4,50	40	72,80 €
KS-VF10001.0015U.50	15	5	5,00	40	75,67 €
KS-VF10001.0015U.55	15	5	5,50	40	90,30 €
KS-VF10001.0015U.60	15	5	6,00	40	93,18 €



KS-VF10001 VHM-KREISSÄGEBLATT, FEINVERZAHNT

Ø 20MM

Artikel-Nr. Article-No.	Durchmesser	Bohrung	Stärke	Zähnezahl	Preis/Euro Price/Euro
KS-VF10001.0020U.02	20	5	0,20	80	19,86 €
KS-VF10001.0020U.025	20	5	0,25	64	19,86 €
KS-VF10001.0020U.03	20	5	0,30	64	19,86 €
KS-VF10001.0020U.035	20	5	0,35	64	19,86 €
KS-VF10001.0020U.04	20	5	0,40	64	19,86 €
KS-VF10001.0020U.05	20	5	0,50	48	19,86 €
KS-VF10001.0020U.06	20	5	0,60	48	19,86 €
KS-VF10001.0020U.07	20	5	0,70	48	23,12 €
KS-VF10001.0020U.08	20	5	0,80	48	23,12 €
KS-VF10001.0020U.09	20	5	0,90	40	24,15 €
KS-VF10001.0020U.10	20	5	1,00	40	24,74 €
KS-VF10001.0020U.11	20	5	1,10	40	25,99 €
KS-VF10001.0020U.12	20	5	1,20	40	25,99 €
KS-VF10001.0020U.13	20	5	1,30	40	27,52 €
KS-VF10001.0020U.14	20	5	1,40	40	29,31 €
KS-VF10001.0020U.15	20	5	1,50	40	29,31 €
KS-VF10001.0020U.16	20	5	1,60	40	30,66 €
KS-VF10001.0020U.17	20	5	1,70	40	32,29 €
KS-VF10001.0020U.18	20	5	1,80	32	32,29 €
KS-VF10001.0020U.19	20	5	1,90	32	33,51 €
KS-VF10001.0020U.20	20	5	2,00	32	33,51 €
KS-VF10001.0020U.25	20	5	2,50	32	41,46 €
KS-VF10001.0020U.30	20	5	3,00	32	47,33 €
KS-VF10001.0020U.35	20	5	3,50	24	53,31 €
KS-VF10001.0020U.40	20	5	4,00	24	63,40 €
KS-VF10001.0020U.45	20	5	4,50	24	75,67 €
KS-VF10001.0020U.50	20	5	5,00	24	78,73 €
KS-VF10001.0020U.55	20	5	5,50	24	91,63 €
KS-VF10001.0020U.60	20	5	6,00	24	94,53 €



KS-VF10001

VHM-KREISSÄGEBLATT, FEINVERZAHNT

Ø 25MM

Artikel-Nr. Article-No.	Durchmesser	Bohrung	Stärke	Zähnezahl	Preis/Euro Price/Euro
KS-VF10001.0025U.02	25	8	0,20	80	20,33 €
KS-VF10001.0025U.025	25	8	0,25	80	20,33 €
KS-VF10001.0025U.03	25	8	0,30	80	20,33 €
KS-VF10001.0025U.035	25	8	0,35	64	20,33 €
KS-VF10001.0025U.04	25	8	0,40	64	20,33 €
KS-VF10001.0025U.05	25	8	0,50	64	23,63 €
KS-VF10001.0025U.06	25	8	0,60	64	23,63 €
KS-VF10001.0025U.07	25	8	0,70	48	24,57 €
KS-VF10001.0025U.08	25	8	0,80	48	27,10 €
KS-VF10001.0025U.09	25	8	0,90	48	29,39 €
KS-VF10001.0025U.10	25	8	1,00	48	29,39 €
KS-VF10001.0025U.11	25	8	1,10	48	33,19 €
KS-VF10001.0025U.12	25	8	1,20	48	33,19 €
KS-VF10001.0025U.13	25	8	1,30	40	34,38 €
KS-VF10001.0025U.14	25	8	1,40	40	35,72 €
KS-VF10001.0025U.15	25	8	1,50	40	35,72 €
KS-VF10001.0025U.16	25	8	1,60	40	38,95 €
KS-VF10001.0025U.17	25	8	1,70	40	38,95 €
KS-VF10001.0025U.18	25	8	1,80	40	40,19 €
KS-VF10001.0025U.19	25	8	1,90	40	42,98 €
KS-VF10001.0025U.20	25	8	2,00	40	44,25 €
KS-VF10001.0025U.25	25	8	2,50	40	53,73 €
KS-VF10001.0025U.30	25	8	3,00	32	69,96 €
KS-VF10001.0025U.35	25	8	3,50	32	77,13 €
KS-VF10001.0025U.40	25	8	4,00	32	87,23 €
KS-VF10001.0025U.45	25	8	4,50	32	99,94 €
KS-VF10001.0025U.50	25	8	5,00	32	105,63 €
KS-VF10001.0025U.55	25	8	5,50	24	120,13 €
KS-VF10001.0025U.60	25	8	6,00	24	125,82 €



KS-VF10001 VHM-KREISSÄGEBLATT, FEINVERZAHNT

Ø 30MM

Artikel-Nr. Article-No.	Durchmesser	Bohrung	Stärke	Zähnezahl	Preis/Euro Price/Euro
KS-VF10001.0030U.02	30	8	0,20	100	24,57 €
KS-VF10001.0030U.025	30	8	0,25	100	24,57 €
KS-VF10001.0030U.03	30	8	0,30	80	24,57 €
KS-VF10001.0030U.035	30	8	0,35	80	24,57 €
KS-VF10001.0030U.04	30	8	0,40	80	24,57 €
KS-VF10001.0030U.05	30	8	0,50	80	25,55 €
KS-VF10001.0030U.06	30	8	0,60	64	25,55 €
KS-VF10001.0030U.07	30	8	0,70	64	30,19 €
KS-VF10001.0030U.08	30	8	0,80	64	33,19 €
KS-VF10001.0030U.09	30	8	0,90	64	35,72 €
KS-VF10001.0030U.10	30	8	1,00	64	35,72 €
KS-VF10001.0030U.11	30	8	1,10	64	39,46 €
KS-VF10001.0030U.12	30	8	1,20	48	40,19 €
KS-VF10001.0030U.13	30	8	1,30	48	41,46 €
KS-VF10001.0030U.14	30	8	1,40	48	45,15 €
KS-VF10001.0030U.15	30	8	1,50	48	45,15 €
KS-VF10001.0030U.16	30	8	1,60	48	48,02 €
KS-VF10001.0030U.17	30	8	1,70	48	48,02 €
KS-VF10001.0030U.18	30	8	1,80	48	49,38 €
KS-VF10001.0030U.19	30	8	1,90	48	50,86 €
KS-VF10001.0030U.20	30	8	2,00	48	52,16 €
KS-VF10001.0030U.25	30	8	2,50	40	61,34 €
KS-VF10001.0030U.30	30	8	3,00	40	72,99 €
KS-VF10001.0030U.35	30	8	3,50	40	82,84 €
KS-VF10001.0030U.40	30	8	4,00	40	92,92 €
KS-VF10001.0030U.45	30	8	4,50	32	107,20 €
KS-VF10001.0030U.50	30	8	5,00	32	112,89 €
KS-VF10001.0030U.55	30	8	5,50	32	127,12 €
KS-VF10001.0030U.60	30	8	6,00	32	132,83 €



KS-VF10001

VHM-KREISSÄGEBLATT, FEINVERZAHNT

Ø 40MM

Artikel-Nr. Article-No.	Durchmesser	Bohrung	Stärke	Zähnezahl	Preis/Euro Price/Euro
KS-VF10001.0040U.02	40	10	0,20	128	29,31 €
KS-VF10001.0040U.025	40	10	0,25	100	29,31 €
KS-VF10001.0040U.03	40	10	0,30	100	29,31 €
KS-VF10001.0040U.035	40	10	0,35	100	29,31 €
KS-VF10001.0040U.04	40	10	0,40	100	30,90 €
KS-VF10001.0040U.05	40	10	0,50	80	33,61 €
KS-VF10001.0040U.06	40	10	0,60	80	33,61 €
KS-VF10001.0040U.07	40	10	0,70	80	37,88 €
KS-VF10001.0040U.08	40	10	0,80	80	38,99 €
KS-VF10001.0040U.09	40	10	0,90	64	38,99 €
KS-VF10001.0040U.10	40	10	1,00	64	40,69 €
KS-VF10001.0040U.11	40	10	1,10	64	41,65 €
KS-VF10001.0040U.12	40	10	1,20	64	43,23 €
KS-VF10001.0040U.13	40	10	1,30	64	43,85 €
KS-VF10001.0040U.14	40	10	1,40	64	46,72 €
KS-VF10001.0040U.15	40	10	1,50	64	48,02 €
KS-VF10001.0040U.16	40	10	1,60	64	49,38 €
KS-VF10001.0040U.17	40	10	1,70	48	52,16 €
KS-VF10001.0040U.18	40	10	1,80	48	53,49 €
KS-VF10001.0040U.19	40	10	1,90	48	55,03 €
KS-VF10001.0040U.20	40	10	2,00	48	55,03 €
KS-VF10001.0040U.25	40	10	2,50	48	70,83 €
KS-VF10001.0040U.30	40	10	3,00	48	81,99 €
KS-VF10001.0040U.35	40	10	3,50	48	91,63 €
KS-VF10001.0040U.40	40	10	4,00	40	101,54 €
KS-VF10001.0040U.45	40	10	4,50	40	115,27 €
KS-VF10001.0040U.50	40	10	5,00	40	122,29 €
KS-VF10001.0040U.55	40	10	5,50	40	137,47 €
KS-VF10001.0040U.60	40	10	6,00	40	144,47 €



KS-VF10001 VHM-KREISSÄGEBLATT, FEINVERZAHNT

Ø 50MM

Artikel-Nr. Article-No.	Durchmesser	Bohrung	Stärke	Zähnezahl	Preis/Euro Price/Euro
KS-VF10001.0050U.02	50	13	0,20	128	46,72 €
KS-VF10001.0050U.025	50	13	0,25	128	45,15 €
KS-VF10001.0050U.03	50	13	0,30	128	38,78 €
KS-VF10001.0050U.035	50	13	0,35	100	38,78 €
KS-VF10001.0050U.04	50	13	0,40	100	38,78 €
KS-VF10001.0050U.05	50	13	0,50	100	39,69 €
KS-VF10001.0050U.06	50	13	0,60	100	39,69 €
KS-VF10001.0050U.07	50	13	0,70	80	41,65 €
KS-VF10001.0050U.08	50	13	0,80	80	45,15 €
KS-VF10001.0050U.09	50	13	0,90	80	46,59 €
KS-VF10001.0050U.10	50	13	1,00	80	48,02 €
KS-VF10001.0050U.11	50	13	1,10	80	49,38 €
KS-VF10001.0050U.12	50	13	1,20	80	50,86 €
KS-VF10001.0050U.13	50	13	1,30	64	57,00 €
KS-VF10001.0050U.14	50	13	1,40	64	58,27 €
KS-VF10001.0050U.15	50	13	1,50	64	61,22 €
KS-VF10001.0050U.16	50	13	1,60	64	62,50 €
KS-VF10001.0050U.17	50	13	1,70	64	63,40 €
KS-VF10001.0050U.18	50	13	1,80	64	67,49 €
KS-VF10001.0050U.19	50	13	1,90	64	67,49 €
KS-VF10001.0050U.20	50	13	2,00	64	69,51 €
KS-VF10001.0050U.25	50	13	2,50	64	84,86 €
KS-VF10001.0050U.30	50	13	3,00	48	98,62 €
KS-VF10001.0050U.35	50	13	3,50	48	112,49 €
KS-VF10001.0050U.40	50	13	4,00	48	119,53 €
KS-VF10001.0050U.45	50	13	4,50	48	138,94 €
KS-VF10001.0050U.50	50	13	5,00	48	145,93 €
KS-VF10001.0050U.55	50	13	5,50	40	162,43 €
KS-VF10001.0050U.60	50	13	6,00	40	169,45 €



KS-VF10001

VHM-KREISSÄGEBLATT, FEINVERZAHNT

Ø 63MM

Artikel-Nr. Article-No.	Durchmesser	Bohrung	Stärke	Zähnezahl	Preis/Euro Price/Euro
KS-VF10001.0063U.02	63	16	0,20	160	71,02 €
KS-VF10001.0063U.025	63	16	0,25	160	68,36 €
KS-VF10001.0063U.03	63	16	0,30	128	63,66 €
KS-VF10001.0063U.035	63	16	0,35	128	60,16 €
KS-VF10001.0063U.04	63	16	0,40	128	54,34 €
KS-VF10001.0063U.05	63	16	0,50	128	53,15 €
KS-VF10001.0063U.06	63	16	0,60	100	54,34 €
KS-VF10001.0063U.07	63	16	0,70	100	61,34 €
KS-VF10001.0063U.08	63	16	0,80	100	67,49 €
KS-VF10001.0063U.09	63	16	0,90	100	68,36 €
KS-VF10001.0063U.10	63	16	1,00	100	69,80 €
KS-VF10001.0063U.11	63	16	1,10	80	72,41 €
KS-VF10001.0063U.12	63	16	1,20	80	75,05 €
KS-VF10001.0063U.13	63	16	1,30	80	76,81 €
KS-VF10001.0063U.14	63	16	1,40	80	78,04 €
KS-VF10001.0063U.15	63	16	1,50	80	79,44 €
KS-VF10001.0063U.16	63	16	1,60	80	83,28 €
KS-VF10001.0063U.17	63	16	1,70	80	87,68 €
KS-VF10001.0063U.18	63	16	1,80	80	89,08 €
KS-VF10001.0063U.19	63	16	1,90	80	92,92 €
KS-VF10001.0063U.20	63	16	2,00	80	96,08 €
KS-VF10001.0063U.25	63	16	2,50	64	115,35 €
KS-VF10001.0063U.30	63	16	3,00	64	130,62 €
KS-VF10001.0063U.35	63	16	3,50	64	149,92 €
KS-VF10001.0063U.40	63	16	4,00	64	163,96 €
KS-VF10001.0063U.45	63	16	4,50	64	187,59 €
KS-VF10001.0063U.50	63	16	5,00	48	196,02 €
KS-VF10001.0063U.55	63	16	5,50	48	219,68 €
KS-VF10001.0063U.60	63	16	6,00	48	230,08 €



KS-VF10001 VHM-KREISSÄGEBLATT, FEINVERZAHNT

Ø 80MM

Artikel-Nr. Article-No.	Durchmesser	Bohrung	Stärke	Zähnezahl	Preis/Euro Price/Euro
KS-VF10001.0080U.03	80	22	0,30	160	126,75 €
KS-VF10001.0080U.035	80	22	0,35	128	123,61 €
KS-VF10001.0080U.04	80	22	0,40	128	118,35 €
KS-VF10001.0080U.05	80	22	0,50	128	89,08 €
KS-VF10001.0080U.06	80	22	0,60	128	86,45 €
KS-VF10001.0080U.07	80	22	0,70	100	93,46 €
KS-VF10001.0080U.08	80	22	0,80	100	93,46 €
KS-VF10001.0080U.09	80	22	0,90	100	97,32 €
KS-VF10001.0080U.10	80	22	1,00	100	97,32 €
KS-VF10001.0080U.11	80	22	1,10	100	99,94 €
KS-VF10001.0080U.12	80	22	1,20	100	104,33 €
KS-VF10001.0080U.13	80	22	1,30	100	108,71 €
KS-VF10001.0080U.14	80	22	1,40	100	112,74 €
KS-VF10001.0080U.15	80	22	1,50	80	115,35 €
KS-VF10001.0080U.16	80	22	1,60	80	118,35 €
KS-VF10001.0080U.17	80	22	1,70	80	127,98 €
KS-VF10001.0080U.18	80	22	1,80	80	129,38 €
KS-VF10001.0080U.19	80	22	1,90	80	132,06 €
KS-VF10001.0080U.20	80	22	2,00	80	136,39 €
KS-VF10001.0080U.25	80	22	2,50	64	161,28 €
KS-VF10001.0080U.30	80	22	3,00	64	193,39 €
KS-VF10001.0080U.35	80	22	3,50	64	213,90 €
KS-VF10001.0080U.40	80	22	4,00	64	231,93 €
KS-VF10001.0080U.45	80	22	4,50	64	273,49 €
KS-VF10001.0080U.50	80	22	5,00	64	281,91 €
KS-VF10001.0080U.55	80	22	5,50	40	312,62 €
KS-VF10001.0080U.60	80	22	6,00	40	320,82 €



KS-VF10001

VHM-KREISSÄGEBLATT, FEINVERZAHNT

Ø 100MM

Artikel-Nr. Article-No.	Durchmesser	Bohrung	Stärke	Zähnezahl	Preis/Euro Price/Euro
KS-VF10001.0100U.05	100	22	0,50	160	164,83 €
KS-VF10001.0100U.06	100	22	0,60	160	157,80 €
KS-VF10001.0100U.07	100	22	0,70	128	151,66 €
KS-VF10001.0100U.08	100	22	0,80	128	138,49 €
KS-VF10001.0100U.09	100	22	0,90	128	135,91 €
KS-VF10001.0100U.10	100	22	1,00	128	125,37 €
KS-VF10001.0100U.11	100	22	1,10	128	131,47 €
KS-VF10001.0100U.12	100	22	1,20	128	138,49 €
KS-VF10001.0100U.13	100	22	1,30	100	147,26 €
KS-VF10001.0100U.14	100	22	1,40	100	153,41 €
KS-VF10001.0100U.15	100	22	1,50	100	157,80 €
KS-VF10001.0100U.16	100	22	1,60	100	166,54 €
KS-VF10001.0100U.17	100	22	1,70	100	175,32 €
KS-VF10001.0100U.18	100	22	1,80	100	175,32 €
KS-VF10001.0100U.19	100	22	1,90	100	191,10 €
KS-VF10001.0100U.20	100	22	2,00	100	195,49 €
KS-VF10001.0100U.25	100	22	2,50	100	230,56 €
KS-VF10001.0100U.30	100	22	3,00	80	258,60 €
KS-VF10001.0100U.35	100	22	3,50	80	293,66 €
KS-VF10001.0100U.40	100	22	4,00	80	322,58 €
KS-VF10001.0100U.45	100	22	4,50	80	376,90 €
KS-VF10001.0100U.50	100	22	5,00	80	393,76 €
KS-VF10001.0100U.55	100	22	5,50	64	449,52 €
KS-VF10001.0100U.60	100	22	6,00	64	467,14 €



KS-VF10001 VHM-KREISSÄGEBLATT, FEINVERZAHNT

Ø 125MM

Artikel-Nr. Article-No.	Durchmesser	Bohrung	Stärke	Zähnezahl	Preis/Euro Price/Euro
KS-VF10001.0125U.06	125	22	0,60	160	243,38 €
KS-VF10001.0125U.07	125	22	0,70	160	238,90 €
KS-VF10001.0125U.08	125	22	0,80	160	232,32 €
KS-VF10001.0125U.09	125	22	0,90	160	230,56 €
KS-VF10001.0125U.10	125	22	1,00	160	203,50 €
KS-VF10001.0125U.11	125	22	1,10	128	210,59 €
KS-VF10001.0125U.12	125	22	1,20	128	223,87 €
KS-VF10001.0125U.13	125	22	1,30	128	245,98 €
KS-VF10001.0125U.14	125	22	1,40	128	245,98 €
KS-VF10001.0125U.15	125	22	1,50	128	254,23 €
KS-VF10001.0125U.16	125	22	1,60	128	267,95 €
KS-VF10001.0125U.17	125	22	1,70	128	287,58 €
KS-VF10001.0125U.18	125	22	1,80	128	290,27 €
KS-VF10001.0125U.19	125	22	1,90	128	312,57 €
KS-VF10001.0125U.20	125	22	2,00	128	312,57 €
KS-VF10001.0125U.25	125	22	2,50	100	372,28 €
KS-VF10001.0125U.30	125	22	3,00	100	439,87 €
KS-VF10001.0125U.35	125	22	3,50	100	504,78 €
KS-VF10001.0125U.40	125	22	4,00	100	575,08 €
KS-VF10001.0125U.45	125	22	4,50	100	644,53 €
KS-VF10001.0125U.50	125	22	5,00	80	665,22 €
KS-VF10001.0125U.55	125	22	5,50	80	784,14 €
KS-VF10001.0125U.60	125	22	6,00	80	813,96 €



KS-VF10001 VHM-KREISSÄGEBLATT, FEINVERZAHNT

Ø 160MM

Artikel-Nr. Article-No.	Durchmesser	Bohrung	Stärke	Zähnezahl	Preis/Euro Price/Euro
KS-VF10001.0160U.10	160	32	1,00	160	417,27 €
KS-VF10001.0160U.12	160	32	1,20	160	416,15 €
KS-VF10001.0160U.15	160	32	1,50	160	434,03 €
KS-VF10001.0160U.16	160	32	1,60	160	442,99 €
KS-VF10001.0160U.20	160	32	2,00	128	566,30 €
KS-VF10001.0160U.25	160	32	2,50	128	645,96 €
KS-VF10001.0160U.30	160	32	3,00	128	695,50 €
KS-VF10001.0160U.40	160	32	4,00	128	911,38 €

Ø 200MM

Artikel-Nr. Article-No.	Durchmesser	Bohrung	Stärke	Zähnezahl	Preis/Euro Price/Euro
KS-VF10001.0200U.15	200	32	1,50	160	822,93 €
KS-VF10001.0200U.16	200	32	1,60	160	837,06 €
KS-VF10001.0200U.20	200	32	2,00	160	1.009,55 €
KS-VF10001.0200U.25	200	32	2,50	160	1.168,20 €
KS-VF10001.0200U.30	200	32	3,00	128	1.325,02 €
KS-VF10001.0200U.40	200	32	4,00	128	1.654,96 €



KS-VF10001

VHM-KREISSÄGEBLATT, FEINVERZAHNT

MATERIALBESCHREIBUNG

		Vc m/min von/bis		fz mm/Z	
				Start- und Max-Werte untere Grenze	
P.1	<500N/mm	150	250	0,010	0,030
P.2	<650N/mm	120	180	0,005	0,025
P.3	<800N/mm	100	180	0,005	0,025
P.4	<1000N/mm	60	120	0,003	0,015
P.5	<1400N/mm	30	60	0,002	0,010
P.6	Einsatz-ST <1000N/mm	70	120	0,004	0,015
P.7	Nitrier-ST <1000N/mm	70	120	0,004	0,015
P.8	Vergütung-ST 850N/mm	110	180	0,004	0,015
P.9	Werkzeug-ST 1000N/mm	70	120	0,004	0,015
M.1	VA <750N/mm	70	150	0,005	0,015
M.2	VA >750N/mm	60	120	0,005	0,015
K.1	Gusseisen <200HB	100	150	0,005	0,012
K.2	Temperguss	100	150	0,005	0,012
K.3	Gusseisen mit Kugelgrafit				
N.1	AL <5%	450	1800	0,015	0,040
N.2	AL <10%	400	1000	0,015	0,040
N.3	AL >10%	300	600	0,010	0,035
N.4	Ms, Cu, Bronze, Rotguss	250	600	0,015	0,035
N.5	Duro-Thermoplast	400	600	0,030	0,050
N.6	Grafit, GFK				
S.1	Titan				
S.2	Nickel				
H.1	45-52 HRC				
H.2	52-60 HRC				
H.3	60-65 HRC				

KS-VG20001

VHM-KREISSÄGEBLATT, GROBVERZAHNT



Ø 15MM

Artikel-Nr. Article-No.	Durchmesser	Bohrung	Stärke	Zähnezahl	Preis/Euro Price/Euro
KS-VG20001.0015U.02	15	5	0,20	20	18,15 €
KS-VG20001.0015U.025	15	5	0,25	20	18,15 €
KS-VG20001.0015U.03	15	5	0,30	20	18,15 €
KS-VG20001.0015U.035	15	5	0,35	20	18,15 €
KS-VG20001.0015U.04	15	5	0,40	20	18,15 €
KS-VG20001.0015U.05	15	5	0,50	20	18,15 €
KS-VG20001.0015U.06	15	5	0,60	20	18,15 €
KS-VG20001.0015U.07	15	5	0,70	20	21,68 €
KS-VG20001.0015U.08	15	5	0,80	20	21,68 €
KS-VG20001.0015U.09	15	5	0,90	20	22,33 €
KS-VG20001.0015U.10	15	5	1,00	20	23,12 €
KS-VG20001.0015U.11	15	5	1,10	20	24,15 €
KS-VG20001.0015U.12	15	5	1,20	20	24,15 €
KS-VG20001.0015U.13	15	5	1,30	20	24,15 €
KS-VG20001.0015U.14	15	5	1,40	20	24,15 €
KS-VG20001.0015U.15	15	5	1,50	20	24,74 €
KS-VG20001.0015U.16	15	5	1,60	20	25,99 €
KS-VG20001.0015U.17	15	5	1,70	20	28,26 €
KS-VG20001.0015U.18	15	5	1,80	20	28,26 €
KS-VG20001.0015U.19	15	5	1,90	20	29,39 €
KS-VG20001.0015U.20	15	5	2,00	20	29,03 €
KS-VG20001.0015U.25	15	5	2,50	20	39,28 €
KS-VG20001.0015U.30	15	5	3,00	20	44,52 €
KS-VG20001.0015U.35	15	5	3,50	20	50,23 €
KS-VG20001.0015U.40	15	5	4,00	20	62,05 €
KS-VG20001.0015U.45	15	5	4,50	20	72,80 €
KS-VG20001.0015U.50	15	5	5,00	20	75,67 €
KS-VG20001.0015U.55	15	5	5,50	20	90,30 €
KS-VG20001.0015U.60	15	5	6,00	20	93,17 €



KS-VG20001 VHM-KREISSÄGEBLATT, GROBVERZAHNT

Ø 20MM

Artikel-Nr. Article-No.	Durchmesser	Bohrung	Stärke	Zähnezahl	Preis/Euro Price/Euro
KS-VG20001.0020U.02	20	5	0,20	20	19,86 €
KS-VG20001.0020U.025	20	5	0,25	20	19,86 €
KS-VG20001.0020U.03	20	5	0,30	20	19,86 €
KS-VG20001.0020U.035	20	5	0,35	20	19,86 €
KS-VG20001.0020U.04	20	5	0,40	20	19,86 €
KS-VG20001.0020U.05	20	5	0,50	20	19,86 €
KS-VG20001.0020U.06	20	5	0,60	20	19,86 €
KS-VG20001.0020U.07	20	5	0,70	20	23,12 €
KS-VG20001.0020U.08	20	5	0,80	20	23,12 €
KS-VG20001.0020U.09	20	5	0,90	20	24,15 €
KS-VG20001.0020U.10	20	5	1,00	20	24,74 €
KS-VG20001.0020U.11	20	5	1,10	20	25,99 €
KS-VG20001.0020U.12	20	5	1,20	20	25,99 €
KS-VG20001.0020U.13	20	5	1,30	20	27,52 €
KS-VG20001.0020U.14	20	5	1,40	20	29,31 €
KS-VG20001.0020U.15	20	5	1,50	20	29,31 €
KS-VG20001.0020U.16	20	5	1,60	20	30,66 €
KS-VG20001.0020U.17	20	5	1,70	20	32,29 €
KS-VG20001.0020U.18	20	5	1,80	20	32,29 €
KS-VG20001.0020U.19	20	5	1,90	20	33,51 €
KS-VG20001.0020U.20	20	5	2,00	20	33,51 €
KS-VG20001.0020U.25	20	5	2,50	20	41,46 €
KS-VG20001.0020U.30	20	5	3,00	20	47,33 €
KS-VG20001.0020U.35	20	5	3,50	20	53,31 €
KS-VG20001.0020U.40	20	5	4,00	20	63,40 €
KS-VG20001.0020U.45	20	5	4,50	20	75,67 €
KS-VG20001.0020U.50	20	5	5,00	20	78,73 €
KS-VG20001.0020U.55	20	5	5,50	20	91,63 €
KS-VG20001.0020U.60	20	5	6,00	20	94,53 €



KS-VG20001

VHM-KREISSÄGEBLATT, GROBVERZAHNT

Ø25 MM

Artikel-Nr. Article-No.	Durchmesser	Bohrung	Stärke	Zähnezahl	Preis/Euro Price/Euro
KS-VG20001.0025U.02	25	8	0,20	20	20,33 €
KS-VG20001.0025U.025	25	8	0,25	20	20,33 €
KS-VG20001.0025U.03	25	8	0,30	20	20,33 €
KS-VG20001.0025U.035	25	8	0,35	20	20,33 €
KS-VG20001.0025U.04	25	8	0,40	20	20,33 €
KS-VG20001.0025U.05	25	8	0,50	20	23,63 €
KS-VG20001.0025U.06	25	8	0,60	20	23,63 €
KS-VG20001.0025U.07	25	8	0,70	20	24,57 €
KS-VG20001.0025U.08	25	8	0,80	20	27,10 €
KS-VG20001.0025U.09	25	8	0,90	20	29,39 €
KS-VG20001.0025U.10	25	8	1,00	20	29,39 €
KS-VG20001.0025U.11	25	8	1,10	20	33,19 €
KS-VG20001.0025U.12	25	8	1,20	20	33,19 €
KS-VG20001.0025U.13	25	8	1,30	20	34,38 €
KS-VG20001.0025U.14	25	8	1,40	20	35,72 €
KS-VG20001.0025U.15	25	8	1,50	20	35,72 €
KS-VG20001.0025U.16	25	8	1,60	20	38,95 €
KS-VG20001.0025U.17	25	8	1,70	20	38,95 €
KS-VG20001.0025U.18	25	8	1,80	20	40,19 €
KS-VG20001.0025U.19	25	8	1,90	20	42,98 €
KS-VG20001.0025U.20	25	8	2,00	20	44,25 €
KS-VG20001.0025U.25	25	8	2,50	20	53,73 €
KS-VG20001.0025U.30	25	8	3,00	20	69,96 €
KS-VG20001.0025U.35	25	8	3,50	20	77,13 €
KS-VG20001.0025U.40	25	8	4,00	20	87,23 €
KS-VG20001.0025U.45	25	8	4,50	20	99,94 €
KS-VG20001.0025U.50	25	8	5,00	20	105,63 €
KS-VG20001.0025U.55	25	8	5,50	20	120,13 €
KS-VG20001.0025U.60	25	8	6,00	20	125,82 €



KS-VG20001 VHM-KREISSÄGEBLATT, GROBVERZAHNT

Ø 30MM

Artikel-Nr. Article-No.	Durchmesser	Bohrung	Stärke	Zähnezahl	Preis/Euro Price/Euro
KS-VG20001.0030U.02	30	8	0,20	30	24,57 €
KS-VG20001.0030U.025	30	8	0,25	30	24,57 €
KS-VG20001.0030U.03	30	8	0,30	30	24,57 €
KS-VG20001.0030U.035	30	8	0,35	30	24,57 €
KS-VG20001.0030U.04	30	8	0,40	30	24,57 €
KS-VG20001.0030U.05	30	8	0,50	30	25,55 €
KS-VG20001.0030U.06	30	8	0,60	30	25,55 €
KS-VG20001.0030U.07	30	8	0,70	30	30,19 €
KS-VG20001.0030U.08	30	8	0,80	24	33,19 €
KS-VG20001.0030U.09	30	8	0,90	24	35,72 €
KS-VG20001.0030U.10	30	8	1,00	24	35,72 €
KS-VG20001.0030U.11	30	8	1,10	24	39,46 €
KS-VG20001.0030U.12	30	8	1,20	24	40,19 €
KS-VG20001.0030U.13	30	8	1,30	24	41,46 €
KS-VG20001.0030U.14	30	8	1,40	24	45,15 €
KS-VG20001.0030U.15	30	8	1,50	24	45,15 €
KS-VG20001.0030U.16	30	8	1,60	24	48,02 €
KS-VG20001.0030U.17	30	8	1,70	24	48,02 €
KS-VG20001.0030U.18	30	8	1,80	24	49,38 €
KS-VG20001.0030U.19	30	8	1,90	24	50,86 €
KS-VG20001.0030U.20	30	8	2,00	24	52,16 €
KS-VG20001.0030U.25	30	8	2,50	24	61,34 €
KS-VG20001.0030U.30	30	8	3,00	24	72,99 €
KS-VG20001.0030U.35	30	8	3,50	24	82,84 €
KS-VG20001.0030U.40	30	8	4,00	24	92,92 €
KS-VG20001.0030U.45	30	8	4,50	24	107,20 €
KS-VG20001.0030U.50	30	8	5,00	24	112,89 €
KS-VG20001.0030U.55	30	8	5,50	24	127,12 €
KS-VG20001.0030U.60	30	8	6,00	24	132,83 €



KS-VG20001

VHM-KREISSÄGEBLATT, GROBVERZAHNT

Ø 40MM

Artikel-Nr. Article-No.	Durchmesser	Bohrung	Stärke	Zähnezahl	Preis/Euro Price/Euro
KS-VG20001.0040U.02	40	10	0,20	40	29,31 €
KS-VG20001.0040U.025	40	10	0,25	40	29,31 €
KS-VG20001.0040U.03	40	10	0,30	40	29,31 €
KS-VG20001.0040U.035	40	10	0,35	40	29,31 €
KS-VG20001.0040U.04	40	10	0,40	40	30,90 €
KS-VG20001.0040U.05	40	10	0,50	40	33,61 €
KS-VG20001.0040U.06	40	10	0,60	40	33,61 €
KS-VG20001.0040U.07	40	10	0,70	40	37,88 €
KS-VG20001.0040U.08	40	10	0,80	32	38,99 €
KS-VG20001.0040U.09	40	10	0,90	32	38,99 €
KS-VG20001.0040U.10	40	10	1,00	32	40,69 €
KS-VG20001.0040U.11	40	10	1,10	32	41,65 €
KS-VG20001.0040U.12	40	10	1,20	32	43,23 €
KS-VG20001.0040U.13	40	10	1,30	32	43,85 €
KS-VG20001.0040U.14	40	10	1,40	32	46,72 €
KS-VG20001.0040U.15	40	10	1,50	32	48,02 €
KS-VG20001.0040U.16	40	10	1,60	32	49,38 €
KS-VG20001.0040U.17	40	10	1,70	32	52,16 €
KS-VG20001.0040U.18	40	10	1,80	32	53,49 €
KS-VG20001.0040U.19	40	10	1,90	32	55,03 €
KS-VG20001.0040U.20	40	10	2,00	32	55,03 €
KS-VG20001.0040U.25	40	10	2,50	32	70,83 €
KS-VG20001.0040U.30	40	10	3,00	32	81,99 €
KS-VG20001.0040U.35	40	10	3,50	32	91,63 €
KS-VG20001.0040U.40	40	10	4,00	32	101,54 €
KS-VG20001.0040U.45	40	10	4,50	32	115,27 €
KS-VG20001.0040U.50	40	10	5,00	32	122,29 €
KS-VG20001.0040U.55	40	10	5,50	32	137,47 €
KS-VG20001.0040U.60	40	10	6,00	32	144,47 €



KS-VG20001 VHM-KREISSÄGEBLATT, GROBVERZAHNT

Ø 50MM

Artikel-Nr. Article-No.	Durchmesser	Bohrung	Stärke	Zähnezahl	Preis/Euro Price/Euro
KS-VG20001.0050U.02	50	13	0,20	48	46,72 €
KS-VG20001.0050U.025	50	13	0,25	48	45,15 €
KS-VG20001.0050U.03	50	13	0,30	48	38,78 €
KS-VG20001.0050U.035	50	13	0,35	48	38,78 €
KS-VG20001.0050U.04	50	13	0,40	48	38,78 €
KS-VG20001.0050U.05	50	13	0,50	48	39,69 €
KS-VG20001.0050U.06	50	13	0,60	48	39,69 €
KS-VG20001.0050U.07	50	13	0,70	40	41,65 €
KS-VG20001.0050U.08	50	13	0,80	40	45,15 €
KS-VG20001.0050U.09	50	13	0,90	40	46,59 €
KS-VG20001.0050U.10	50	13	1,00	40	48,02 €
KS-VG20001.0050U.11	50	13	1,10	40	49,38 €
KS-VG20001.0050U.12	50	13	1,20	40	50,86 €
KS-VG20001.0050U.13	50	13	1,30	32	57,00 €
KS-VG20001.0050U.14	50	13	1,40	32	58,27 €
KS-VG20001.0050U.15	50	13	1,50	32	61,22 €
KS-VG20001.0050U.16	50	13	1,60	32	62,50 €
KS-VG20001.0050U.17	50	13	1,70	32	63,40 €
KS-VG20001.0050U.18	50	13	1,80	32	67,49 €
KS-VG20001.0050U.19	50	13	1,90	32	67,49 €
KS-VG20001.0050U.20	50	13	2,00	32	69,51 €
KS-VG20001.0050U.25	50	13	2,50	32	84,86 €
KS-VG20001.0050U.30	50	13	3,00	24	98,62 €
KS-VG20001.0050U.35	50	13	3,50	24	112,49 €
KS-VG20001.0050U.40	50	13	4,00	24	119,53 €
KS-VG20001.0050U.45	50	13	4,50	24	138,94 €
KS-VG20001.0050U.50	50	13	5,00	24	145,93 €
KS-VG20001.0050U.55	50	13	5,50	20	162,43 €
KS-VG20001.0050U.60	50	13	6,00	20	169,45 €



KS-VG20001

VHM-KREISSÄGEBLATT, GROBVERZAHNT

Ø 63MM

Artikel-Nr. Article-No.	Durchmesser	Bohrung	Stärke	Zähnezahl	Preis/Euro Price/Euro
KS-VG20001.0063U.03	63	16	0,30	64	63,66 €
KS-VG20001.0063U.035	63	16	0,35	64	60,16 €
KS-VG20001.0063U.04	63	16	0,40	64	54,34 €
KS-VG20001.0063U.05	63	16	0,50	64	53,15 €
KS-VG20001.0063U.06	63	16	0,60	48	54,34 €
KS-VG20001.0063U.07	63	16	0,70	48	61,34 €
KS-VG20001.0063U.08	63	16	0,80	48	67,49 €
KS-VG20001.0063U.09	63	16	0,90	48	68,36 €
KS-VG20001.0063U.10	63	16	1,00	48	69,80 €
KS-VG20001.0063U.11	63	16	1,10	40	72,41 €
KS-VG20001.0063U.12	63	16	1,20	40	75,05 €
KS-VG20001.0063U.13	63	16	1,30	40	76,81 €
KS-VG20001.0063U.14	63	16	1,40	40	78,04 €
KS-VG20001.0063U.15	63	16	1,50	40	79,44 €
KS-VG20001.0063U.16	63	16	1,60	40	83,28 €
KS-VG20001.0063U.17	63	16	1,70	40	87,68 €
KS-VG20001.0063U.18	63	16	1,80	40	89,08 €
KS-VG20001.0063U.19	63	16	1,90	40	92,92 €
KS-VG20001.0063U.20	63	16	2,00	40	96,08 €
KS-VG20001.0063U.25	63	16	2,50	32	115,35 €
KS-VG20001.0063U.30	63	16	3,00	32	130,62 €
KS-VG20001.0063U.35	63	16	3,50	32	149,92 €
KS-VG20001.0063U.40	63	16	4,00	32	163,96 €
KS-VG20001.0063U.45	63	16	4,50	32	187,59 €
KS-VG20001.0063U.50	63	16	5,00	24	196,02 €
KS-VG20001.0063U.55	63	16	5,50	24	219,68 €
KS-VG20001.0063U.60	63	16	6,00	24	230,08 €



KS-VG20001 VHM-KREISSÄGEBLATT, GROBVERZAHNT

Ø 80MM

Artikel-Nr. Article-No.	Durchmesser	Bohrung	Stärke	Zähnezahl	Preis/Euro Price/Euro
KS-VG20001.0080U.03	80	22	0,30	64	126,75 €
KS-VG20001.0080U.035	80	22	0,35	64	123,61 €
KS-VG20001.0080U.04	80	22	0,40	64	118,35 €
KS-VG20001.0080U.05	80	22	0,50	64	89,08 €
KS-VG20001.0080U.06	80	22	0,60	64	86,45 €
KS-VG20001.0080U.07	80	22	0,70	64	93,46 €
KS-VG20001.0080U.08	80	22	0,80	64	93,46 €
KS-VG20001.0080U.09	80	22	0,90	48	97,32 €
KS-VG20001.0080U.10	80	22	1,00	48	97,32 €
KS-VG20001.0080U.11	80	22	1,10	48	99,94 €
KS-VG20001.0080U.12	80	22	1,20	48	104,33 €
KS-VG20001.0080U.13	80	22	1,30	48	108,71 €
KS-VG20001.0080U.14	80	22	1,40	48	112,74 €
KS-VG20001.0080U.15	80	22	1,50	48	115,35 €
KS-VG20001.0080U.16	80	22	1,60	48	118,35 €
KS-VG20001.0080U.17	80	22	1,70	40	127,98 €
KS-VG20001.0080U.18	80	22	1,80	40	129,38 €
KS-VG20001.0080U.19	80	22	1,90	40	132,06 €
KS-VG20001.0080U.20	80	22	2,00	40	136,39 €
KS-VG20001.0080U.25	80	22	2,50	40	161,28 €
KS-VG20001.0080U.30	80	22	3,00	40	193,39 €
KS-VG20001.0080U.35	80	22	3,50	32	213,90 €
KS-VG20001.0080U.40	80	22	4,00	32	231,93 €
KS-VG20001.0080U.45	80	22	4,50	32	273,49 €
KS-VG20001.0080U.50	80	22	5,00	32	281,91 €
KS-VG20001.0080U.55	80	22	5,50	32	312,62 €
KS-VG20001.0080U.60	80	22	6,00	32	320,82 €



KS-VG20001

VHM-KREISSÄGEBLATT, GROBVERZAHNT

Ø 100MM

Artikel-Nr. Article-No.	Durchmesser	Bohrung	Stärke	Zähnezahl	Preis/Euro Price/Euro
KS-VG20001.0100U.05	100	22	0,50	80	164,83 €
KS-VG20001.0100U.06	100	22	0,60	80	157,80 €
KS-VG20001.0100U.07	100	22	0,70	80	151,66 €
KS-VG20001.0100U.08	100	22	0,80	64	138,49 €
KS-VG20001.0100U.09	100	22	0,90	64	135,91 €
KS-VG20001.0100U.10	100	22	1,00	64	125,37 €
KS-VG20001.0100U.11	100	22	1,10	64	131,47 €
KS-VG20001.0100U.12	100	22	1,20	64	138,49 €
KS-VG20001.0100U.13	100	22	1,30	48	147,26 €
KS-VG20001.0100U.14	100	22	1,40	48	153,41 €
KS-VG20001.0100U.15	100	22	1,50	48	157,80 €
KS-VG20001.0100U.16	100	22	1,60	48	166,54 €
KS-VG20001.0100U.17	100	22	1,70	48	175,32 €
KS-VG20001.0100U.18	100	22	1,80	48	175,32 €
KS-VG20001.0100U.19	100	22	1,90	48	191,10 €
KS-VG20001.0100U.20	100	22	2,00	48	195,49 €
KS-VG20001.0100U.25	100	22	2,50	48	230,56 €
KS-VG20001.0100U.30	100	22	3,00	40	258,60 €
KS-VG20001.0100U.35	100	22	3,50	40	293,66 €
KS-VG20001.0100U.40	100	22	4,00	40	322,58 €
KS-VG20001.0100U.45	100	22	4,50	40	376,90 €
KS-VG20001.0100U.50	100	22	5,00	40	393,76 €
KS-VG20001.0100U.55	100	22	5,50	32	449,52 €
KS-VG20001.0100U.60	100	22	6,00	32	467,14 €



KS-VG20001

VHM-KREISSÄGEBLATT, GROBVERZAHNT

Ø 125MM

Artikel-Nr. Article-No.	Durchmesser	Bohrung	Stärke	Zähnezahl	Preis/Euro Price/Euro
KS-VG20001.0125U.06	125	22	0,60	80	243,38 €
KS-VG20001.0125U.07	125	22	0,70	80	238,90 €
KS-VG20001.0125U.08	125	22	0,80	80	232,32 €
KS-VG20001.0125U.09	125	22	0,90	80	230,56 €
KS-VG20001.0125U.10	125	22	1,00	80	203,50 €
KS-VG20001.0125U.11	125	22	1,10	64	210,59 €
KS-VG20001.0125U.12	125	22	1,20	64	223,87 €
KS-VG20001.0125U.13	125	22	1,30	64	245,98 €
KS-VG20001.0125U.14	125	22	1,40	64	245,98 €
KS-VG20001.0125U.15	125	22	1,50	64	254,23 €
KS-VG20001.0125U.16	125	22	1,60	64	267,95 €
KS-VG20001.0125U.17	125	22	1,70	64	287,58 €
KS-VG20001.0125U.18	125	22	1,80	64	290,27 €
KS-VG20001.0125U.19	125	22	1,90	64	312,57 €
KS-VG20001.0125U.20	125	22	2,00	64	312,57 €
KS-VG20001.0125U.25	125	22	2,50	48	372,28 €
KS-VG20001.0125U.30	125	22	3,00	48	439,87 €
KS-VG20001.0125U.35	125	22	3,50	48	504,78 €
KS-VG20001.0125U.40	125	22	4,00	48	575,08 €
KS-VG20001.0125U.45	125	22	4,50	40	644,53 €
KS-VG20001.0125U.50	125	22	5,00	40	665,22 €
KS-VG20001.0125U.55	125	22	5,50	40	784,14 €
KS-VG20001.0125U.60	125	22	6,00	40	813,96 €

Ø 160MM

Artikel-Nr. Article-No.	Durchmesser	Bohrung	Stärke	Zähnezahl	Preis/Euro Price/Euro
KS-VG20001.0160U.10	160	32	1,00	80	417,27 €
KS-VG20001.0160U.12	160	32	1,20	80	416,15 €
KS-VG20001.0160U.15	160	32	1,50	80	434,03 €
KS-VG20001.0160U.16	160	32	1,60	80	442,99 €
KS-VG20001.0160U.20	160	32	2,00	64	566,30 €
KS-VG20001.0160U.25	160	32	2,50	64	645,96 €
KS-VG20001.0160U.30	160	32	3,00	64	695,50 €
KS-VG20001.0160U.40	160	32	4,00	48	911,38 €



KS-VG20001 VHM-KREISSÄGEBLATT, GROBVERZAHNT

Ø 200MM

Artikel-Nr. Article-No.	Durchmesser	Bohrung	Stärke	Zähnezahl	Preis/Euro Price/Euro
KS-VG20001.0200U.15	200	32	1,50	80	822,93 €
KS-VG20001.0200U.16	200	32	1,60	80	837,06 €
KS-VG20001.0200U.20	200	32	2,00	80	1.009,55 €
KS-VG20001.0200U.25	200	32	2,50	80	1.168,20 €
KS-VG20001.0200U.30	200	32	3,00	64	1.325,02 €
KS-VG2F10001.0200U.40	200	32	4,00	64	1.654,96 €





KS-VG20001

VHM-KREISSÄGEBLATT, GROBVERZAHNT

MATERIALBESCHREIBUNG

		Vc m/min von/bis		fz mm/Z	
				Start- und Max-Werte untere Grenze	
P.1	<500N/mm	150	250	0,010	0,030
P.2	<650N/mm	120	180	0,005	0,025
P.3	<800N/mm	100	180	0,005	0,025
P.4	<1000N/mm	60	120	0,003	0,015
P.5	<1400N/mm	30	60	0,002	0,010
P.6	Einsatz-ST <1000N/mm	70	120	0,004	0,015
P.7	Nitrier-ST <1000N/mm	70	120	0,004	0,015
P.8	Vergütung-ST 850N/mm	110	180	0,004	0,015
P.9	Werkzeug-ST 1000N/mm	70	120	0,004	0,015
M.1	VA <750N/mm	70	150	0,005	0,015
M.2	VA >750N/mm	60	120	0,005	0,015
K.1	Gusseisen <200HB	100	150	0,005	0,012
K.2	Temperguss	100	150	0,005	0,012
K.3	Gusseisen mit Kugelgrafit				
N.1	AL <5%	450	1800	0,015	0,040
N.2	AL <10%	400	1000	0,015	0,040
N.3	AL >10%	300	600	0,010	0,035
N.4	Ms, Cu, Bronze, Rotguss	250	600	0,015	0,035
N.5	Duro-Thermoplast	400	600	0,030	0,050
N.6	Grafit, GFK				
S.1	Titan				
S.2	Nickel				
H.1	45-52 HRC				
H.2	52-60 HRC				
H.3	60-65 HRC				



KS-HF10001

HSS-KREISSÄGEBLATT, FEINVERZAHNT

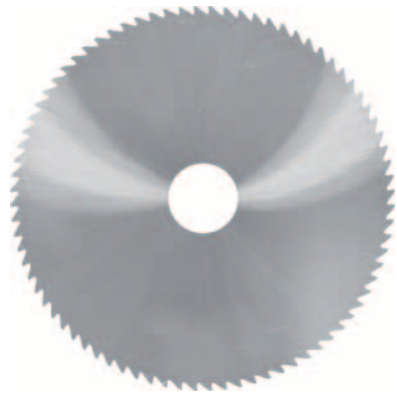

Ø 20MM

Artikel-Nr. Article-No.	Durchmesser	Bohrung	Stärke	Zähnezahl	Preis/Euro Price/Euro
KS-HF10001.0020U.02	20	5	0,20	80	15,10 €
KS-HF10001.0020U.025	20	5	0,25	64	15,10 €
KS-HF10001.0020U.03	20	5	0,30	64	13,49 €
KS-HF10001.0020U.04	20	5	0,40	64	13,49 €
KS-HF10001.0020U.05	20	5	0,50	48	13,07 €
KS-HF10001.0020U.06	20	5	0,60	48	13,07 €
KS-HF10001.0020U.08	20	5	0,80	48	12,75 €
KS-HF10001.0020U.10	20	5	1,00	40	12,75 €
KS-HF10001.0020U.12	20	5	1,20	40	14,73 €
KS-HF10001.0020U.16	20	5	1,60	40	16,15 €
KS-HF10001.0020U.20	20	5	2,00	32	16,47 €
KS-HF10001.0020U.25	20	5	2,50	32	17,55 €
KS-HF10001.0020U.30	20	5	3,00	32	19,04 €
KS-HF10001.0020U.40	20	5	4,00	24	25,16 €
KS-HF10001.0020U.50	20	5	5,00	24	29,48 €
KS-HF10001.0020U.60	20	5	6,00	24	33,61 €



KS-HF10001

HSS-KREISSÄGEBLATT, FEINVERZAHNT

Ø 25MM

Artikel-Nr. Article-No.	Durchmesser	Bohrung	Stärke	Zähnezahl	Preis/Euro Price/Euro
KS-HF10001.0025U.02	25	8	0,20	80	15,52 €
KS-HF10001.0025U.025	25	8	0,25	80	15,52 €
KS-HF10001.0025U.03	25	8	0,30	80	14,31 €
KS-HF10001.0025U.04	25	8	0,40	64	14,31 €
KS-HF10001.0025U.05	25	8	0,50	64	13,70 €
KS-HF10001.0025U.06	25	8	0,60	64	13,70 €
KS-HF10001.0025U.08	25	8	0,80	48	13,25 €
KS-HF10001.0025U.10	25	8	1,00	48	13,25 €
KS-HF10001.0025U.12	25	8	1,20	48	15,20 €
KS-HF10001.0025U.16	25	8	1,60	40	16,23 €
KS-HF10001.0025U.20	25	8	2,00	40	17,39 €
KS-HF10001.0025U.25	25	8	2,50	40	18,88 €
KS-HF10001.0025U.30	25	8	3,00	32	22,12 €
KS-HF10001.0025U.40	25	8	4,00	32	26,74 €
KS-HF10001.0025U.50	25	8	5,00	32	31,26 €
KS-HF10001.0025U.60	25	8	6,00	24	35,01 €

Ø 32MM

Artikel-Nr. Article-No.	Durchmesser	Bohrung	Stärke	Zähnezahl	Preis/Euro Price/Euro
KS-HF10001.0032U.02	32	8	0,20	100	16,23 €
KS-HF10001.0032U.025	32	8	0,25	100	16,23 €
KS-HF10001.0032U.03	32	8	0,30	80	14,73 €
KS-HF10001.0032U.04	32	8	0,40	80	14,73 €
KS-HF10001.0032U.05	32	8	0,50	80	14,25 €
KS-HF10001.0032U.06	32	8	0,60	64	14,25 €
KS-HF10001.0032U.08	32	8	0,80	64	13,86 €
KS-HF10001.0032U.10	32	8	1,00	64	13,86 €
KS-HF10001.0032U.12	32	8	1,20	48	15,91 €
KS-HF10001.0032U.16	32	8	1,60	48	16,76 €
KS-HF10001.0032U.20	32	8	2,00	48	18,18 €
KS-HF10001.0032U.25	32	8	2,50	40	21,49 €
KS-HF10001.0032U.30	32	8	3,00	40	24,31 €
KS-HF10001.0032U.40	32	8	4,00	40	28,60 €
KS-HF10001.0032U.50	32	8	5,00	32	34,45 €
KS-HF10001.0032U.60	32	8	6,00	32	36,75 €



KS-HF10001

HSS-KREISSÄGEBLATT, FEINVERZAHNT

Ø 40MM

Artikel-Nr. Article-No.	Durchmesser	Bohrung	Stärke	Zähnezahl	Preis/Euro Price/Euro
KS-HF10001.0040U.02	40	10	0,20	128	17,97 €
KS-HF10001.0040U.025	40	10	0,25	100	17,97 €
KS-HF10001.0040U.03	40	10	0,30	100	17,22 €
KS-HF10001.0040U.04	40	10	0,40	100	17,22 €
KS-HF10001.0040U.05	40	10	0,50	80	16,06 €
KS-HF10001.0040U.06	40	10	0,60	80	16,06 €
KS-HF10001.0040U.08	40	10	0,80	80	15,23 €
KS-HF10001.0040U.10	40	10	1,00	64	15,23 €
KS-HF10001.0040U.12	40	10	1,20	64	16,68 €
KS-HF10001.0040U.16	40	10	1,60	64	17,64 €
KS-HF10001.0040U.20	40	10	2,00	48	19,13 €
KS-HF10001.0040U.25	40	10	2,50	48	22,97 €
KS-HF10001.0040U.30	40	10	3,00	48	26,74 €
KS-HF10001.0040U.40	40	10	4,00	40	31,68 €
KS-HF10001.0040U.50	40	10	5,00	40	38,06 €
KS-HF10001.0040U.60	40	10	6,00	40	43,02 €

Ø 50MM

Artikel-Nr. Article-No.	Durchmesser	Bohrung	Stärke	Zähnezahl	Preis/Euro Price/Euro
KS-HF10001.0050U.02	50	10	0,20	128	21,15 €
KS-HF10001.0050U.025	50	10	0,25	128	21,15 €
KS-HF10001.0050U.03	50	10	0,30	128	18,96 €
KS-HF10001.0050U.04	50	10	0,40	100	18,96 €
KS-HF10001.0050U.05	50	10	0,50	100	17,64 €
KS-HF10001.0050U.06	50	10	0,60	100	17,64 €
KS-HF10001.0050U.08	50	10	0,80	80	17,09 €
KS-HF10001.0050U.10	50	10	1,00	80	17,09 €
KS-HF10001.0050U.12	50	10	1,20	80	18,33 €
KS-HF10001.0050U.16	50	10	1,60	64	19,92 €
KS-HF10001.0050U.20	50	10	2,00	64	21,49 €
KS-HF10001.0050U.25	50	10	2,50	64	23,36 €
KS-HF10001.0050U.30	50	10	3,00	48	27,57 €
KS-HF10001.0050U.40	50	10	4,00	48	32,37 €
KS-HF10001.0050U.50	50	10	5,00	48	43,38 €
KS-HF10001.0050U.60	50	10	6,00	40	48,28 €

KS-HF10001

HSS-KREISSÄGEBLATT, FEINVERZAHNT

Ø 63MM

Artikel-Nr. Article-No.	Durchmesser	Bohrung	Stärke	Zähnezahl	Preis/Euro Price/Euro
KS-HF10001.0063U.025	63	16	0,25	160	22,65 €
KS-HF10001.0063U.03	63	16	0,30	128	21,49 €
KS-HF10001.0063U.04	63	16	0,40	128	21,49 €
KS-HF10001.0063U.05	63	16	0,50	128	20,20 €
KS-HF10001.0063U.06	63	16	0,60	100	20,20 €
KS-HF10001.0063U.08	63	16	0,80	100	19,28 €
KS-HF10001.0063U.10	63	16	1,00	100	19,46 €
KS-HF10001.0063U.12	63	16	1,20	80	20,12 €
KS-HF10001.0063U.16	63	16	1,60	80	22,23 €
KS-HF10001.0063U.20	63	16	2,00	80	23,91 €
KS-HF10001.0063U.25	63	16	2,50	64	25,34 €
KS-HF10001.0063U.30	63	16	3,00	64	28,36 €
KS-HF10001.0063U.40	63	16	4,00	64	34,95 €
KS-HF10001.0063U.50	63	16	5,00	48	43,80 €
KS-HF10001.0063U.60	63	16	6,00	48	49,04 €

Ø 80MM

Artikel-Nr. Article-No.	Durchmesser	Bohrung	Stärke	Zähnezahl	Preis/Euro Price/Euro
KS-HF10001.0080U.03	80	22	0,30	160	24,66 €
KS-HF10001.0080U.04	80	22	0,40	160	24,66 €
KS-HF10001.0080U.05	80	22	0,50	128	23,50 €
KS-HF10001.0080U.06	80	22	0,60	128	23,50 €
KS-HF10001.0080U.08	80	22	0,80	128	22,65 €
KS-HF10001.0080U.10	80	22	1,00	100	22,65 €
KS-HF10001.0080U.12	80	22	1,20	100	23,42 €
KS-HF10001.0080U.16	80	22	1,60	100	24,84 €
KS-HF10001.0080U.20	80	22	2,00	80	27,29 €
KS-HF10001.0080U.25	80	22	2,50	80	32,43 €
KS-HF10001.0080U.30	80	22	3,00	80	34,95 €
KS-HF10001.0080U.40	80	22	4,00	64	43,27 €
KS-HF10001.0080U.50	80	22	5,00	64	52,70 €
KS-HF10001.0080U.60	80	22	6,00	64	59,14 €



KS-HF10001

HSS-KREISSÄGEBLATT, FEINVERZAHNT

Ø 100MM

Artikel-Nr. Article-No.	Durchmesser	Bohrung	Stärke	Zähnezahl	Preis/Euro Price/Euro
KS-HF10001.0100U.05	100	22	0,50	160	27,40 €
KS-HF10001.0100U.06	100	22	0,60	160	27,40 €
KS-HF10001.0100U.08	100	22	0,80	128	26,40 €
KS-HF10001.0100U.10	100	22	1,00	128	26,40 €
KS-HF10001.0100U.12	100	22	1,20	128	27,40 €
KS-HF10001.0100U.16	100	22	1,60	100	32,69 €
KS-HF10001.0100U.20	100	22	2,00	100	36,33 €
KS-HF10001.0100U.25	100	22	2,50	100	40,90 €
KS-HF10001.0100U.30	100	22	3,00	80	44,20 €
KS-HF10001.0100U.40	100	22	4,00	80	59,14 €
KS-HF10001.0100U.50	100	22	5,00	80	66,06 €
KS-HF10001.0100U.60	100	22	6,00	64	77,18 €

Ø 125MM

Artikel-Nr. Article-No.	Durchmesser	Bohrung	Stärke	Zähnezahl	Preis/Euro Price/Euro
KS-HF10001.0125U.06	125	22	0,60	160	40,90 €
KS-HF10001.0125U.08	125	22	0,80	160	39,04 €
KS-HF10001.0125U.10	125	22	1,00	160	39,04 €
KS-HF10001.0125U.12	125	22	1,20	128	39,41 €
KS-HF10001.0125U.16	125	22	1,60	128	40,77 €
KS-HF10001.0125U.20	125	22	2,00	128	43,56 €
KS-HF10001.0125U.25	125	22	2,50	100	46,17 €
KS-HF10001.0125U.30	125	22	3,00	100	54,34 €
KS-HF10001.0125U.40	125	22	4,00	100	80,66 €
KS-HF10001.0125U.50	125	22	5,00	80	95,67 €
KS-HF10001.0125U.60	125	22	6,00	80	108,05 €

Ø 160MM

Artikel-Nr. Article-No.	Durchmesser	Bohrung	Stärke	Zähnezahl	Preis/Euro Price/Euro
KS-HF10001.0160U.10	160	32	1,00	160	67,25 €
KS-HF10001.0160U.12	160	32	1,20	160	68,07 €
KS-HF10001.0160U.16	160	32	1,60	160	68,90 €
KS-HF10001.0160U.20	160	32	2,00	128	71,36 €
KS-HF10001.0160U.25	160	32	2,50	128	77,50 €
KS-HF10001.0160U.30	160	32	3,00	128	88,18 €
KS-HF10001.0160U.40	160	32	4,00	100	124,06 €
KS-HF10001.0160U.50	160	32	5,00	100	147,63 €
KS-HF10001.0160U.60	160	32	6,00	100	168,34 €



KS-HF10001

HSS-KREISSÄGEBLATT, FEINVERZAHNT

Ø 200MM

Artikel-Nr. Article-No.	Durchmesser	Bohrung	Stärke	Zähnezahl	Preis/Euro Price/Euro
KS-HF10001.0200U.10	200	32	1,00	200	87,55 €
KS-HF10001.0200U.12	200	32	1,20	200	88,56 €
KS-HF10001.0200U.16	200	32	1,60	160	94,53 €
KS-HF10001.0200U.20	200	32	2,00	160	99,93 €
KS-HF10001.0200U.25	200	32	2,50	160	112,57 €
KS-HF10001.0200U.30	200	32	3,00	128	124,67 €
KS-HF10001.0200U.40	200	32	4,00	128	176,76 €
KS-HF10001.0200U.50	200	32	5,00	128	212,04 €
KS-HF10001.0200U.60	200	32	6,00	100	245,77 €

Ø 250MM

Artikel-Nr. Article-No.	Durchmesser	Bohrung	Stärke	Zähnezahl	Preis/Euro Price/Euro
KS-HF10001.0250U.16	250	32	1,60	200	109,70 €
KS-HF10001.0250U.20	250	32	2,00	200	119,55 €
KS-HF10001.0250U.25	250	32	2,50	160	136,65 €
KS-HF10001.0250U.30	250	32	3,00	160	150,71 €
KS-HF10001.0250U.40	250	32	4,00	160	218,59 €
KS-HF10001.0250U.50	250	32	5,00	128	260,61 €
KS-HF10001.0250U.60	250	32	6,00	128	308,79 €

Ø 315MM

Artikel-Nr. Article-No.	Durchmesser	Bohrung	Stärke	Zähnezahl	Preis/Euro Price/Euro
KS-HF10001.0315U.25	315	40	2,50	200	209,96 €
KS-HF10001.0315U.30	315	40	3,00	200	235,69 €
KS-HF10001.0315U.40	315	40	4,00	160	304,46 €
KS-HF10001.0315U.50	315	40	5,00	160	372,69 €
KS-HF10001.0315U.60	315	40	6,00	160	440,85 €



KS-HF10001

HSS-KREISSÄGEBLATT, FEINVERZAHNT

MATERIALBESCHREIBUNG

				fz mm/Z	
		Vc m/min von/bis		Start- und Max-Werte untere Grenze	
P.1	<500N/mm	40	60	0,02	0,04
P.2	<650N/mm	30	40	0,02	0,04
P.3	<800N/mm	25	35	0,02	0,03
P.4	<1000N/mm	20	30	0,01	0,02
P.5	<1400N/mm	15	25	0,01	0,02
P.6	Einsatz-ST <1000N/mm	20	30	0,01	0,02
P.7	Nitrier-ST <1000N/mm	20	30	0,01	0,02
P.8	Vergütung-ST 850N/mm	25	35	0,01	0,02
P.9	Werkzeug-ST 1000N/mm	15	25	0,01	0,02
M.1	VA <750N/mm				
M.2	VA >750N/mm				
K.1	Gusseisen <200HB	20	30	0,02	0,05
K.2	Temperguss	30	40	0,02	0,05
K.3	Gusseisen mit Kugelgrafit				
N.1	AL <5%	400	700	0,03	0,07
N.2	AL <10%	200	500	0,03	0,07
N.3	AL >10%	150	250	0,02	0,06
N.4	Ms, Cu, Bronze, Rotguss	200	300	0,02	0,05
N.5	Duro-Thermoplast	100	300	0,02	0,06
N.6	Grafit, GFK				
S.1	Titan				
S.2	Nickel				
H.1	45-52 HRC				
H.2	52-60 HRC				
H.3	60-65 HRC				



KS-HG20001

HSS-KREISSÄGEBLATT, GROBVERZAHNT



Ø 50MM

Artikel-Nr. Article-No.	Durchmesser	Bohrung	Stärke	Zähnezahl	Preis/Euro Price/Euro
KS-HG20001.0050U.05	50	10	0,50	48	17,64 €
KS-HG20001.0050U.06	50	10	0,60	48	17,64 €
KS-HG20001.0050U.08	50	10	0,80	40	17,09 €
KS-HG20001.0050U.10	50	10	1,00	40	17,09 €
KS-HG20001.0050U.12	50	10	1,20	40	18,33 €
KS-HG20001.0050U.16	50	10	1,60	32	19,92 €
KS-HG20001.0050U.20	50	10	2,00	32	21,49 €
KS-HG20001.0050U.25	50	10	2,50	32	23,36 €
KS-HG20001.0050U.30	50	10	3,00	24	27,57 €
KS-HG20001.0050U.40	50	10	4,00	24	32,37 €
KS-HG20001.0050U.50	50	10	5,00	24	43,38 €
KS-HG20001.0050U.60	50	10	6,00	20	48,28 €

Ø 63MM

Artikel-Nr. Article-No.	Durchmesser	Bohrung	Stärke	Zähnezahl	Preis/Euro Price/Euro
KS-HG20001.0063U.05	63	16	0,50	64	20,20 €
KS-HG20001.0063U.06	63	16	0,60	48	20,20 €
KS-HG20001.0063U.08	63	16	0,80	48	19,28 €
KS-HG20001.0063U.10	63	16	1,00	48	19,46 €
KS-HG20001.0063U.12	63	16	1,20	40	20,12 €
KS-HG20001.0063U.16	63	16	1,60	40	22,23 €
KS-HG20001.0063U.20	63	16	2,00	40	23,91 €
KS-HG20001.0063U.25	63	16	2,50	32	25,34 €
KS-HG20001.0063U.30	63	16	3,00	32	28,36 €
KS-HG20001.0063U.40	63	16	4,00	32	34,95 €
KS-HG20001.0063U.50	63	16	5,00	24	43,80 €
KS-HG20001.0063U.60	63	16	6,00	24	49,04 €



KS-HG20001

HSS-KREISSÄGEBLATT, GROBVERZAHNT

Ø 80MM

Artikel-Nr. Article-No.	Durchmesser	Bohrung	Stärke	Zähnezahl	Preis/Euro Price/Euro
KS-HG20001.0080U.05	80	22	0,50	64	23,50 €
KS-HG20001.0080U.06	80	22	0,60	64	23,50 €
KS-HG20001.0080U.08	80	22	0,80	64	22,65 €
KS-HG20001.0080U.10	80	22	1,00	48	22,65 €
KS-HG20001.0080U.12	80	22	1,20	48	23,42 €
KS-HG20001.0080U.16	80	22	1,60	48	24,84 €
KS-HG20001.0080U.20	80	22	2,00	40	27,29 €
KS-HG20001.0080U.25	80	22	2,50	40	32,43 €
KS-HG20001.0080U.30	80	22	3,00	40	34,95 €
KS-HG20001.0080U.40	80	22	4,00	32	43,27 €
KS-HG20001.0080U.50	80	22	5,00	32	52,70 €
KS-HG20001.0080U.60	80	22	6,00	32	59,14 €

Ø 100MM

Artikel-Nr. Article-No.	Durchmesser	Bohrung	Stärke	Zähnezahl	Preis/Euro Price/Euro
KS-HG20001.0100U.05	100	22	0,50	80	27,40 €
KS-HG20001.0100U.06	100	22	0,60	80	27,40 €
KS-HG20001.0100U.08	100	22	0,80	64	26,40 €
KS-HG20001.0100U.10	100	22	1,00	64	26,40 €
KS-HG20001.0100U.12	100	22	1,20	64	27,40 €
KS-HG20001.0100U.16	100	22	1,60	48	32,69 €
KS-HG20001.0100U.20	100	22	2,00	48	36,33 €
KS-HG20001.0100U.25	100	22	2,50	48	40,90 €
KS-HG20001.0100U.30	100	22	3,00	40	44,20 €
KS-HG20001.0100U.40	100	22	4,00	40	59,14 €
KS-HG20001.0100U.50	100	22	5,00	40	66,06 €
KS-HG20001.0100U.60	100	22	6,00	32	77,18 €



KS-HG20001 HSS-KREISSÄGEBLATT, GROBVERZAHNT

Ø 125MM

Artikel-Nr. Article-No.	Durchmesser	Bohrung	Stärke	Zähnezahl	Preis/Euro Price/Euro
KS-HG20001.0125U.06	125	22	0,60	80	40,90 €
KS-HG20001.0125U.08	125	22	0,80	80	39,04 €
KS-HG20001.0125U.10	125	22	1,00	80	39,04 €
KS-HG20001.0125U.12	125	22	1,20	64	39,41 €
KS-HG20001.0125U.16	125	22	1,60	64	40,77 €
KS-HG20001.0125U.20	125	22	2,00	64	43,56 €
KS-HG20001.0125U.25	125	22	2,50	48	46,17 €
KS-HG20001.0125U.30	125	22	3,00	48	54,34 €
KS-HG20001.0125U.40	125	22	4,00	48	80,66 €
KS-HG20001.0125U.50	125	22	5,00	40	95,67 €
KS-HG20001.0125U.60	125	22	6,00	40	108,05 €

Ø160MM

Artikel-Nr. Article-No.	Durchmesser	Bohrung	Stärke	Zähnezahl	Preis/Euro Price/Euro
KS-HG20001.0160U.10	160	32	1,00	80	67,25 €
KS-HG20001.0160U.12	160	32	1,20	80	68,07 €
KS-HG20001.0160U.16	160	32	1,60	80	68,90 €
KS-HG20001.0160U.20	160	32	2,00	64	71,36 €
KS-HG20001.0160U.25	160	32	2,50	64	77,50 €
KS-HG20001.0160U.30	160	32	3,00	64	88,18 €
KS-HG20001.0160U.40	160	32	4,00	48	124,06 €
KS-HG20001.0160U.50	160	32	5,00	48	147,63 €
KS-HG20001.0160U.60	160	32	6,00	48	168,34 €



KS-HG20001

HSS-KREISSÄGEBLATT, GROBVERZAHNT

Ø 200MM

Artikel-Nr. Article-No.	Durchmesser	Bohrung	Stärke	Zähnezahl	Preis/Euro Price/Euro
KS-HG20001.0200U.10	200	32	1,00	100	87,55 €
KS-HG20001.0200U.12	200	32	1,20	100	88,56 €
KS-HG20001.0200U.16	200	32	1,60	80	94,53 €
KS-HG20001.0200U.20	200	32	2,00	80	99,93 €
KS-HG20001.0200U.25	200	32	2,50	80	112,57 €
KS-HG20001.0200U.30	200	32	3,00	64	124,67 €
KS-HG20001.0200U.40	200	32	4,00	64	176,76 €
KS-HG20001.0200U.50	200	32	5,00	64	212,04 €
KS-HG20001.0200U.60	200	32	6,00	48	245,77 €

Ø 250MM

Artikel-Nr. Article-No.	Durchmesser	Bohrung	Stärke	Zähnezahl	Preis/Euro Price/Euro
KS-HG20001.0250U.16	250	32	1,60	100	109,70 €
KS-HG20001.0250U.20	250	32	2,00	100	119,55 €
KS-HG20001.0250U.25	250	32	2,50	80	136,65 €
KS-HG20001.0250U.30	250	32	3,00	80	150,71 €
KS-HG20001.0250U.40	250	32	4,00	80	218,59 €
KS-HG20001.0250U.50	250	32	5,00	64	260,61 €
KS-HG20001.0250U.60	250	32	6,00	64	308,79 €

Ø 315MM

Artikel-Nr. Article-No.	Durchmesser	Bohrung	Stärke	Zähnezahl	Preis/Euro Price/Euro
KS-HG20001.0315U.25	315	40	2,50	100	209,96 €
KS-HG20001.0315U.30	315	40	3,00	100	235,69 €
KS-HG20001.0315U.40	315	40	4,00	80	304,46 €
KS-HG20001.0315U.50	315	40	5,00	80	372,69 €
KS-HG20001.0315U.60	315	40	6,00	80	440,85 €



KS-HG20001 HSS-KREISSÄGEBLATT, GROBVERZAHNT

MATERIALBESCHREIBUNG

		Vc m/min von/bis		fz mm/Z Start- und Max-Werte untere Grenze	
P.1	<500N/mm	40	60	0,02	0,04
P.2	<650N/mm	30	40	0,02	0,04
P.3	<800N/mm	25	35	0,02	0,03
P.4	<1000N/mm	20	30	0,01	0,02
P.5	<1400N/mm	15	25	0,01	0,02
P.6	Einsatz-ST <1000N/mm	20	30	0,01	0,02
P.7	Nitrier-ST <1000N/mm	20	30	0,01	0,02
P.8	Vergütung-ST 850N/mm	25	35	0,01	0,02
P.9	Werkzeug-ST 1000N/mm	15	25	0,01	0,02
M.1	VA <750N/mm				
M.2	VA >750N/mm				
K.1	Gusseisen <200HB	20	30	0,02	0,05
K.2	Temperguss	30	40	0,02	0,05
K.3	Gusseisen mit Kugelgrafit				
N.1	AL <5%	400	700	0,03	0,07
N.2	AL <10%	200	500	0,03	0,07
N.3	AL >10%	150	250	0,02	0,06
N.4	Ms, Cu, Bronze, Rotguss	200	300	0,02	0,05
N.5	Duro-Thermoplast	100	300	0,02	0,06
N.6	Grafit, GFK				
S.1	Titan				
S.2	Nickel				
H.1	45-52 HRC				
H.2	52-60 HRC				
H.3	60-65 HRC				



KS-HG30001

HSS-KREISSÄGEBLATT, GROBVERZAHNT FORM C



Ø 50MM

Artikel-Nr. Article-No.	Durchmesser	Bohrung	Stärke	Zähnezahl	Preis/Euro Price/Euro
KS-HG30001.0050U.10	50	10	1,00	40	22,05 €
KS-HG30001.0050U.12	50	10	1,20	40	23,13 €
KS-HG30001.0050U.16	50	10	1,60	32	25,23 €
KS-HG30001.0050U.20	50	10	2,00	32	26,16 €
KS-HG30001.0050U.25	50	10	2,50	32	27,81 €
KS-HG30001.0050U.30	50	10	3,00	24	30,11 €
KS-HG30001.0050U.40	50	10	4,00	24	38,96 €
KS-HG30001.0050U.50	50	10	5,00	24	48,51 €
KS-HG30001.0050U.60	50	10	6,00	20	52,94 €

Ø 63MM

Artikel-Nr. Article-No.	Durchmesser	Bohrung	Stärke	Zähnezahl	Preis/Euro Price/Euro
KS-HG30001.0063U.10	63	16	1,00	48	24,23 €
KS-HG30001.0063U.12	63	16	1,20	40	24,60 €
KS-HG30001.0063U.16	63	16	1,60	40	27,81 €
KS-HG30001.0063U.20	63	16	2,00	40	29,90 €
KS-HG30001.0063U.25	63	16	2,50	32	31,29 €
KS-HG30001.0063U.30	63	16	3,00	32	34,69 €
KS-HG30001.0063U.40	63	16	4,00	32	41,91 €
KS-HG30001.0063U.50	63	16	5,00	24	49,13 €
KS-HG30001.0063U.60	63	16	6,00	24	54,50 €



KS-HG30001

HSS-KREISSÄGEBLATT, GROBVERZAHNT FORM C

Ø 80MM

Artikel-Nr. Article-No.	Durchmesser	Bohrung	Stärke	Zähnezahl	Preis/Euro Price/Euro
KS-HG30001.0080U.10	80	22	1,00	48	26,95 €
KS-HG30001.0080U.12	80	22	1,20	48	27,89 €
KS-HG30001.0080U.16	80	22	1,60	48	29,82 €
KS-HG30001.0080U.20	80	22	2,00	40	30,87 €
KS-HG30001.0080U.25	80	22	2,50	40	37,11 €
KS-HG30001.0080U.30	80	22	3,00	40	40,51 €
KS-HG30001.0080U.40	80	22	4,00	32	49,46 €
KS-HG30001.0080U.50	80	22	5,00	32	59,02 €
KS-HG30001.0080U.60	80	22	6,00	32	68,48 €

Ø 100MM

Artikel-Nr. Article-No.	Durchmesser	Bohrung	Stärke	Zähnezahl	Preis/Euro Price/Euro
KS-HG30001.0100U.10	100	22	1,00	64	30,26 €
KS-HG30001.0100U.12	100	22	1,20	64	31,13 €
KS-HG30001.0100U.16	100	22	1,60	48	37,56 €
KS-HG30001.0100U.20	100	22	2,00	48	40,83 €
KS-HG30001.0100U.25	100	22	2,50	48	44,62 €
KS-HG30001.0100U.30	100	22	3,00	40	48,51 €
KS-HG30001.0100U.40	100	22	4,00	40	65,66 €
KS-HG30001.0100U.50	100	22	5,00	40	71,36 €
KS-HG30001.0100U.60	100	22	6,00	32	82,60 €

Ø 125MM

Artikel-Nr. Article-No.	Durchmesser	Bohrung	Stärke	Zähnezahl	Preis/Euro Price/Euro
KS-HG30001.0125U.10	125	22	1,00	80	46,02 €
KS-HG30001.0125U.12	125	22	1,20	64	46,02 €
KS-HG30001.0125U.16	125	22	1,60	64	47,97 €
KS-HG30001.0125U.20	125	22	2,00	64	49,04 €
KS-HG30001.0125U.25	125	22	2,50	48	49,76 €
KS-HG30001.0125U.30	125	22	3,00	48	58,44 €
KS-HG30001.0125U.40	125	22	4,00	48	93,83 €
KS-HG30001.0125U.50	125	22	5,00	40	106,84 €
KS-HG30001.0125U.60	125	22	6,00	40	118,61 €



KS-HG30001

HSS-KREISSÄGEBLATT, GROBVERZAHNT FORM C

Ø160MM

Artikel-Nr. Article-No.	Durchmesser	Bohrung	Stärke	Zähnezahl	Preis/Euro Price/Euro
KS-HG30001.0160U.10	200	32	1,00	100	96,69 €
KS-HG30001.0160U.12	200	32	1,20	100	97,61 €
KS-HG30001.0160U.16	200	32	1,60	80	104,07 €
KS-HG30001.0160U.20	200	32	2,00	80	108,46 €
KS-HG30001.0160U.25	200	32	2,50	80	122,42 €
KS-HG30001.0160U.30	200	32	3,00	64	138,52 €
KS-HG30001.0160U.40	200	32	4,00	64	196,54 €
KS-HG30001.0160U.50	200	32	5,00	64	233,98 €
KS-HG30001.0160U.60	200	32	6,00	48	269,33 €

Ø 200MM

Artikel-Nr. Article-No.	Durchmesser	Bohrung	Stärke	Zähnezahl	Preis/Euro Price/Euro
KS-HG30001.0200U.10	200	32	1,00	100	96,69 €
KS-HG30001.0200U.12	200	32	1,20	100	97,61 €
KS-HG30001.0200U.16	200	32	1,60	80	104,07 €
KS-HG30001.0200U.20	200	32	2,00	80	108,46 €
KS-HG30001.0200U.25	200	32	2,50	80	122,42 €
KS-HG30001.0200U.30	200	32	3,00	64	138,52 €
KS-HG30001.0200U.40	200	32	4,00	64	196,54 €
KS-HG30001.0200U.50	200	32	5,00	64	233,98 €
KS-HG30001.0200U.60	200	32	6,00	48	269,33 €

Ø 250MM

Artikel-Nr. Article-No.	Durchmesser	Bohrung	Stärke	Zähnezahl	Preis/Euro Price/Euro
KS-HG30001.0250U.16	250	32	1,60	100	116,06 €
KS-HG30001.0250U.20	250	32	2,00	100	127,54 €
KS-HG30001.0250U.25	250	32	2,50	80	146,19 €
KS-HG30001.0250U.30	250	32	3,00	80	163,10 €
KS-HG30001.0250U.40	250	32	4,00	80	230,53 €
KS-HG30001.0250U.50	250	32	5,00	64	274,81 €
KS-HG30001.0250U.60	250	32	6,00	64	324,98 €



KS-HG30001

HSS-KREISSÄGEBLATT, GROBVERZAHNT FORM C

Ø 315MM

Artikel-Nr. Article-No.	Durchmesser	Bohrung	Stärke	Zähnezahl	Preis/Euro Price/Euro
KS-HG30001.0315U.25	315	40	2,50	100	223,71 €
KS-HG30001.0315U.30	315	40	3,00	100	249,78 €
KS-HG30001.0315U.40	315	40	4,00	80	319,50 €
KS-HG30001.0315U.50	315	40	5,00	80	391,93 €
KS-HG30001.0315U.60	315	40	6,00	80	463,64 €

MATERIALBESCHREIBUNG

		Vc m/min von/bis		fz mm/Z	
				Start- und Max-Werte untere Grenze	
P.1	<500N/mm	40	60	0,02	0,04
P.2	<650N/mm	30	40	0,02	0,04
P.3	<800N/mm	25	35	0,02	0,03
P.4	<1000N/mm	20	30	0,01	0,02
P.5	<1400N/mm	15	25	0,01	0,02
P.6	Einsatz-ST <1000N/mm	20	30	0,01	0,02
P.7	Nitrier-ST <1000N/mm	20	30	0,01	0,02
P.8	Vergütung-ST 850N/mm	25	35	0,01	0,02
P.9	Werkzeug-ST 1000N/mm	15	25	0,01	0,02
M.1	VA <750N/mm				
M.2	VA >750N/mm				
K.1	Gusseisen <200HB	20	30	0,02	0,05
K.2	Temperguss	30	40	0,02	0,05
K.3	Gusseisen mit Kugelgrafit				
N.1	AL <5%	400	700	0,03	0,07
N.2	AL <10%	200	500	0,03	0,07
N.3	AL >10%	150	250	0,02	0,06
N.4	Ms, Cu, Bronze, Rotguss	200	300	0,02	0,05
N.5	Duro-Thermoplast	100	300	0,02	0,06
N.6	Grafit, GFK				
S.1	Titan				
S.2	Nickel				
H.1	45-52 HRC				
H.2	52-60 HRC				
H.3	60-65 HRC				

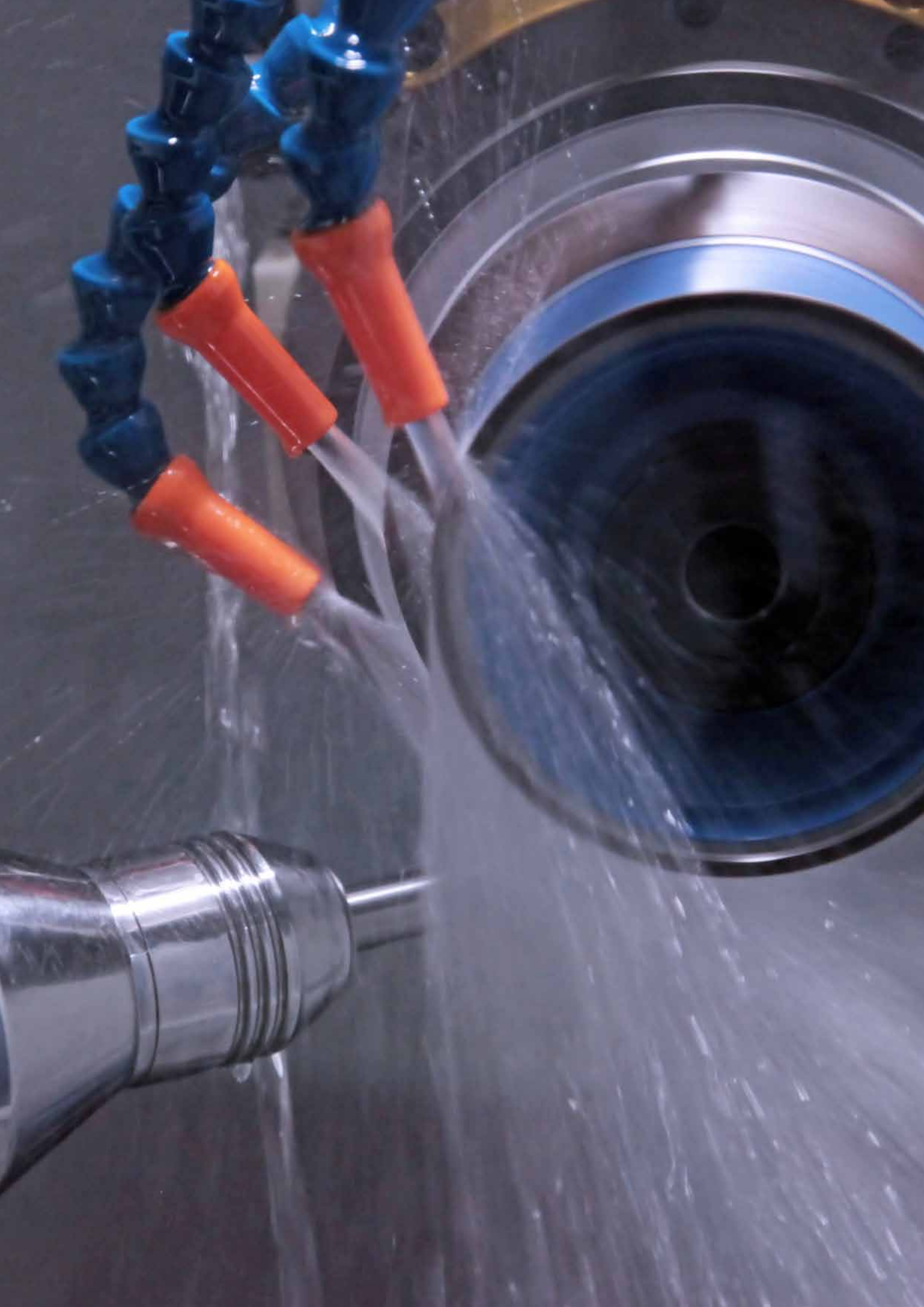

TECHNIK



HALLAS
TOOLS



PROBLEMLÖSUNGEN BOHREN

PROBLEM	URSACHE	LÖSUNGSMÖGLICHKEIT
Schneideckenausbrüche	Falscher Kernlochbohrer	Richtigen Kernlochbohrer einsetzen
	Vorschub zu hoch	Vorschub verringern
	Zu hoher Verschleiß des Gewindebohrers	Das Gesamtumfeld überprüfen
	Überschreitung Verschleißmarkenbreite	Werkzeug rechtzeitig nachschärfen bzw. ersetzen
	Instabile Arbeitsverhältnisse	Spindelspiel beseitigen
	Instabile Werkstückspannung	Werkstückspannung überprüfen
	Zu viel Hinterschliff	Ordnungsgemäß nachschärfen
Schlechte Oberflächenqualität der Bohrung	Ungenauere Positionsgenauigkeit	Bohrung vorab anzentrieren
	Vorschub zu niedrig	Vorschub erhöhen
Riss im Kern	Ausspitzung zu stark	Ordnungsgemäß nachschärfen
	Schlag auf die Querschneide	Schlag auf die Querschneide vermeiden
	Vorschub zu hoch	Vorschub reduzieren
	Zu wenig Hinterschliff	Ordnungsgemäß nachschärfen
Bohrung zu groß	Spanstau	Richtiges Werkzeug einsetzen
	Anschliff nicht korrekt	Anschliff überprüfen
	Vorschub zu hoch	Vorschub reduzieren
	Rundlauffehler des eingesetzten Bohrers	Rundlauffehler bestmöglich reduzieren
Bohrung zu klein	Kernlochbohrer mit zu geringem Durchmesser	Kernlochbohrer an die richtige Werkstoffgruppe anpassen
	Schnittgeschwindigkeit zu hoch	Schnittgeschwindigkeit reduzieren
Bildung von Aufbauschneiden	Kühlschmiermittelzusammensetzung nicht korrekt	Für korrekte Kühlschmiermittelzusammensetzung sorgen
	Kühlschmiermittelzufuhr nicht ausreichend	Für ausreichende Kühlschmiermittelzufuhr sorgen
	Unbeschichtetes Werkzeug	Beschichtetes Werkzeug einsetzen
	Schnittgeschwindigkeit zu niedrig	Schnittgeschwindigkeit erhöhen
Standlänge zu gering	Instabile Werkstückspannung	Für stabile Werkstückspannung sorgen
	Falsche Schnittdaten	Schnittdaten an Bearbeitung anpassen
	Kühlschmiermittelzusammensetzung nicht korrekt	Für korrekte Kühlschmiermittelzusammensetzung sorgen
	Kühlschmiermittelzufuhr nicht ausreichend	Für ausreichende Kühlschmiermittelzufuhr sorgen



PROBLEMLÖSUNGEN BOHREN

PROBLEM	URSACHE	LÖSUNGSMÖGLICHKEIT
Grat am Bohrungsaustritt	Vorschub zu hoch	Vorschub verringern
	Überschreitung Verschleißmarkenbreite	Werkzeug rechtzeitig nachschärfen bzw. ersetzen
Vibrationen	Instabile Werkstückspannung	Für stabile Werkstückspannung sorgen
	Zu großer Rundlauffehler des Kernlochbohrers	Rundlauffehler minimieren
	Vorschub zu niedrig	Vorschub erhöhen
	Schnittgeschwindigkeit zu hoch	Schnittgeschwindigkeit reduzieren
Bruch des Nutenauslaufs	Bohrer im Spannfutter nicht stabil	Bohrer korrekt ins Spannfutter einsetzen
	Schlechte Spanabfuhr	Früher entspanen
Führungsfasenverschleiß	Kühlschmiermittelzusammensetzung nicht korrekt	Für korrekte Kühlschmiermittelzusammensetzung sorgen
	Kühlschmiermittelzufuhr nicht ausreichend	Für ausreichende Kühlschmiermittelzufuhr sorgen
	Schnittgeschwindigkeit zu hoch	Schnittgeschwindigkeit reduzieren
	Zu großer Rundlauffehler des Kernlochbohrers	Rundlauffehler minimieren
	Verjüngung am Werkzeug zu gering	Werkzeug mit größerer Verjüngung verwenden
Freiflächenverschleiß	Freiwinkel zu klein	Freiwinkel erhöhen
	Schnittgeschwindigkeit zu hoch	Schnittgeschwindigkeit reduzieren
	Vorschub zu niedrig	Vorschub erhöhen
Querschneidenverschleiß	Kühlschmiermittelzusammensetzung nicht korrekt	Für korrekte Kühlschmiermittelzusammensetzung sorgen
	Kühlschmiermittelzufuhr nicht ausreichend	Für ausreichende Kühlschmiermittelzufuhr sorgen
	Schnittgeschwindigkeit zu niedrig	Schnittgeschwindigkeit erhöhen
	Vorschub zu hoch	Vorschub reduzieren
Eckenverschleiß	Überhöhte Geschwindigkeit	Auf ideale Geschwindigkeit verringern evtl. Vorschub erhöhen



PROBLEMLÖSUNGEN GEWINDEBOHRER

PROBLEM	URSACHE	LÖSUNGSMÖGLICHKEIT
Gewindebohrerbruch	Spanstau bzw.-verklemmung	Gewindebohrerwahl an den Bearbeitungsfall anpassen
	Werkzeuggeometrie für den Bearbeitungsfall ungeeignet	Das richtige Gewindewerkzeug wählen
	Zu hoher Verschleiß des Gewindebohrers	Das Gesamtumfeld überprüfen
	Drehmoment zu hoch	Gewindeschneidvorrichtung mit Überlastungskupplung verwenden
	Gewindekernloch zu eng	Schnittwerte und Kernlochbohrung überprüfen (Kernlochbohrertabelle)
Gewinde zu eng	Falsches Gewindewerkzeug	Gewindebohrer an die richtige Werkstoffgruppe anpassen
	Falsche Toleranz	Die Toleranz des Gewindebohrers überprüfen ggf. Werkzeug anpassen
	Zu kleine Kernlochbohrung	Für die richtige Kernlochbohrung sorgen (Kernlochbohrertabelle, Schnittwerte überprüfen)
	Zu enges Gewinde	Für die richtige Werkzeuggeometrie sorgen
Gewinde zu groß	Falsches Gewindewerkzeug	Gewindebohrer an das Material anpassen
	Falsche Toleranz	Die Toleranz des Gewindebohrers überprüfen ggf. Werkzeug austauschen
	Gewindebohrer arbeitet nicht zentrisch	Die Werkzeughalterung überprüfen und das Zentrum des Gewindebohrers über dem Loch positionieren
	Schnittgeschwindigkeit zu hoch	Schnittgeschwindigkeit anpassen
	Kühlschmiermittelzufuhr nicht ausreichend	Für gute Kühlschmiermittelzufuhr sorgen
	Zu kleine Kernlochbohrung	Für die richtige Kernlochbohrung sorgen (siehe Kernlochbohrertabelle)
	Spanstau	Die richtige Werkzeuggeometrie einsetzen
	Falschen Axialvorschub gewählt	Vorschub um 5-10% verringern bzw. Anpressdruck der Gewindeschneidvorrichtung überprüfen
	Zu hoher Verschleiß	Falsches Gewindewerkzeug
	Kühlschmiermittelzufuhr nicht ausreichend	Für gute Kühlschmiermittelzufuhr sorgen
	Kühlschmiermittelszusammensetzung nicht korrekt	Für korrekte Kühlschmiermittelszusammensetzung sorgen
	Schnittgeschwindigkeit zu hoch	Schnittgeschwindigkeit anpassen

PROBLEMLÖSUNGEN GEWINDEBOHRER

PROBLEM	URSACHE	LÖSUNGSMÖGLICHKEIT
Unsaubere Gewindeoberflächen	Spanstau	Für richtige Werkzeuggeometrie sorgen
	Kaltschweißungen an Gewindebohrerflanken	Kaltschweißungen entfernen bzw. neues Werkzeug einsetzen
	Werkzeuggeometrie falsch gewählt	Für richtige Wahl des Gewindewerkzeuges sorgen
	Schnittgeschwindigkeit zu hoch	Schnittgeschwindigkeit reduzieren
	Kühlschmiermittelzufuhr nicht ausreichend	Für gute Kühlschmiermittelzufuhr sorgen
	Kühlschmiermittelzusammensetzung nicht korrekt	Für korrekte Kühlschmiermittelzusammensetzung sorgen
	Falschen Axialvorschub gewählt	Vorschub um 5-10% verringern bzw. Anpressdruck der Gewindeschneidvorrichtung überprüfen
Überhitzung des Gewindebohrers	Kühlschmiermittelzufuhr nicht ausreichend	Kühlschmiermittelzufuhr überprüfen
	Kühlschmiermittelzusammensetzung nicht korrekt	Für korrekte Kühlschmiermittelzusammensetzung sorgen
	Gewindebohrer ist verschlissen	Den Gewindebohrer rechtzeitig austauschen
	Linksspiralige Gewindebohrer erhalten zu geringen Anschnittsdruck	Den Gewindebohrer in Druckbereich des Gewindeschneidfutters halten. Stärkeres axiales Andrücken beim Anschneiden
	Stark rechtsspiralige Gewindebohrer werden mit zu starkem Anschnittsdruck eingesetzt	Nur minimales Andrücken beim Anschneiden
Ausbrüche am Werkzeug	Falsches Gewindewerkzeug	Gewindebohrer an das richtige Material anpassen und richtige Geometrie wählen
	Oberflächenverhärtung	Geschwindigkeit reduzieren, beschichtetes Werkzeug anwenden
	Kernlochbohrung zu eng	Kühlschmiermittelzusammensetzung überprüfen
	Kühlschmiermittelzufuhr nicht ausreichend	Für richtige Kernlochbohrung sorgen (siehe Kernlochbohrertabelle)
	Kühlschmiermittelzusammensetzung nicht korrekt	Für korrekte Kühlschmiermittelzusammensetzung sorgen



PROBLEMLÖSUNGEN REIBEN

PROBLEM	URSACHE	LÖSUNGSMÖGLICHKEIT
Schlechte Oberflächenqualität	Werkzeugverschleiß	Werkzeug rechtzeitig nachschärfen bzw. ersetzen
	Kühlschmiermittelzufuhr nicht korrekt	Für korrekte Kühlschmiermittelzufuhr sorgen
	Kühlschmiermittelzusammensetzung nicht korrekt	Für korrekte Kühlschmiermittelzusammensetzung sorgen
	Falsche Werkzeuggeometrie	Die richtige Geometrie wählen
	Vorschub zu niedrig	Vorschub erhöhen
	Schneidenauslauf scharfkantig	Schneidenauslauf glätten und verrunden
	Schneiden sind im Eingriff ungleichmäßig	Führungsteil und Anschnitt gleichmäßig verjüngt oder rund schleifen
	Anschnitt minderwertig	Anschnitt läppen oder feinstschleifen, Übergang zum Führungsteil glätten oder verrunden
	Werkstück neigt zum Kleben (Aufbauschneide)	Die Werkzeugwahl auf Richtigkeit überprüfen
	Schnittgeschwindigkeit zu niedrig	Schnittgeschwindigkeit erhöhen
Rattermarken in der Bohrung	Werkstück instabil	Für stabiles Werkstück sorgen
	Werkstückspannung instabil	Für stabile Werkstückspannung sorgen
	Spanabnahme ungleichmäßig bzw. zu gering	Werkzeugaufmaß erhöhen
	Führung ungenügend	Pendelhalter bzw. Führungsreibahlen einsetzen
	Freiwinkel zu groß	Freiwinkel beim Nachschleifen am Anschnitt verkleinern
	Rundlauf nicht korrekt	Werkzeug und Spindelrundlauf überprüfen, zylindrisch spannen
	Schnittgeschwindigkeit zu hoch	Schnittgeschwindigkeit reduzieren
	Vorschub zu niedrig	Vorschub erhöhen
	Vorschub ungleichmäßig	Vorschub- und Drehbewegung gleichzeitig und gleichmäßig ausführen
Konische oder unrunde Bohrung	Sitz in der Maschinenspindel nicht korrekt	Spindel und deren Sitz überprüfen
	Rundlauf nicht korrekt	Werkzeug zentrisch spannen, Pendelhalter bzw. Führungsreibahle einsetzen
	Ausrichtungsfehler zwischen Werkzeug und Bohrung	Stirnschneidende Reibahle verwenden
	Freiwinkel zu groß	Freiwinkel beim Anschleifen anpassen
	Asymmetrischer Anschnittwinkel	Anschnittwinkel nachschleifen



PROBLEMLÖSUNGEN FRÄSEN

PROBLEM	URSACHE	LÖSUNGSMÖGLICHKEIT
Konische oder unrunde Bohrung	Führung ungenügend	Führungsreibahle verwenden, genauer führen
	Anschnitt unrund	Anschnitt gleichmäßig rund und scharf schleifen
Durchmesser zu eng	Vorschub zu niedrig	Vorschub erhöhen
	Anschnitt zu lang	Kürzeren Anschnitt wählen
	Werkzeug verschliffen	Werkzeug überprüfen, rechtzeitig austauschen
	Schnittgeschwindigkeit zu niedrig	Schnittgeschwindigkeit erhöhen
	Werkstoff hat unnachgiebige Struktur bzw. hohe Dichte	Reibahlundurchmesser vergrößern
	Geringe Spanabnahme	Bearbeitungsaufmaß anpassen
	Reibahle mit zu geringem Aufmaß	Größeres Aufmaß verwenden
	Werkzeughdurchmesser zu klein	Richtigen Durchmesser einsetzen
Durchmesser zu groß	Übermäßige Hitzeentwicklung beim Reiben Bohrung zieht sich zusammen	Kühlschmiermittelzufuhr erhöhen
	Vorschub zu hoch	Verschub verringern
	Anschnitt ungleichmäßig bzw. zu kurz	Anschnittwinkel verkleinern bzw. Anschnitt verlängern
	Schnittgeschwindigkeit zu hoch	Schnittgeschwindigkeit reduzieren
	Durch nachgiebige Struktur bzw. niedrige Dichte weitet sich Werkstoff	Reibahlundurchmesser verringern
	Maschinenspindelrundlauf oder Werkzeug nicht korrekt	Pendelhalter einsetzen, Reibahle führen bzw. zentrisch spannen
	Kühlschmiermittelzusammensetzung nicht korrekt	Für korrekte Kühlschmiermittelzusammensetzung sorgen
Kühlschmiermittelzufuhr nicht ausreichend	Für korrekte Kühlschmiermittelzufuhr sorgen	
Abgebrochene oder verformte Mitnehmer	Falscher Sitz zwischen Schaft und Spannmittel	Schaft und Spannmittel unbeschädigt und sauber halten
Unterweite am Lochausgang	Vorschub beim Austreten des Werkzeugs aus der Bohrung zu groß	Vorschub kurz vor Durchgang reduzieren bzw. gleichmäßigen Vorschub wählen
Werkzeug bricht oder klemmt	Halslänge zu kurz	Das richtige Fräswerkzeug wählen
	Bohrung zu eng Werkzeugverschleiß	Werkzeug rechtzeitig nachschärfen bzw. ersetzen
	Fasenbreite zu groß	Das richtige Fräswerkzeug wählen
Starker Verschleiß	Zu geringes Aufmaß	Durchmesser vergrößern



PROBLEMLÖSUNGEN FRÄSEN

PROBLEM	URSACHE	LÖSUNGSMÖGLICHKEIT
Schlechte Oberflächenqualität	Kühlschmiermittelzufuhr nicht korrekt	Für korrekte Kühlschmiermittelzufuhr sorgen
	Bildung einer Aufbauschneide	Werkzeug mit höherem Drallwinkel verwenden Schnittigeres Werkzeug wählen
	Spangröße zu groß	Zerspanungsquerschnitt verringern
	Spanabfuhr nicht korrekt	Kühlschmiermittelzufuhr anpassen Die Werkzeugauswahl auf Richtigkeit überprüfen
	Vorschub zu hoch	Vorschub reduzieren
	Drehzahl zu niedrig	Drehzahl erhöhen
	Werkzeugverschleiß	Werkzeug rechtzeitig nachschärfen bzw. ersetzen
	Falsche Fräserwahl	Fräser an Material anpassen
Längsmarkierungen an der Oberfläche	Ausbrüche an Mantelschneiden	Werkzeug ersetzen
Rattermarken an der Oberfläche	Werkzeugspannung labil	Spannmittel überprüfen, ggf. ersetzen
	Werkzeug nicht stabil	Werkzeug mit größerem Schaft verwenden
	Werkzeuggrundlauffehler	Rundlauffehler minimieren
Werkzeugbruch	Vorschub zu hoch	Vorschub verringern
	Zu großer Zerspanungsquerschnitt	Vorschub pro Zahn anpassen
	Werkzeu glänge zu lang	Wenn möglich kürzeste Ausführung verwenden
Zu hoher Verschleiß	Falscher Fräser	Fräser an Material anpassen
	Falscher Drallwinkel	Werkzeug mit richtigem Drallwinkel wählen
	Falsche Schnittdaten	Schnittdaten an Bearbeitung anpassen
	Gegenlaufräsen	Werkzeug im Gleichlauf einsetzen
Extremer Kolkverschleiß	Zu hohe Zerspanungstemperatur	Schnittgeschwindigkeit reduzieren
	Schnittdruck zu hoch	Vorschub reduzieren
Schneidkanten- ausbrüche	Werkstückstabilität	Spannmittel überprüfen, ggf. anpassen
	Werkzeugstabilität	Wenn möglich kürzeste Ausführung wählen
	Gegenlaufräsen	Werkzeug im Gleichlauf einsetzen



PROBLEMLÖSUNGEN FRÄSEN

PROBLEM	URSACHE	LÖSUNGSMÖGLICHKEIT
Schneidkanten- ausbrüche	Schneidstoff zu spröde	Fräser aus höherwertigem Schneidstoff verwenden
	Falsche Fräser	Fräser an Material anpassen
	Vorschub zu hoch	Vorschub verringern
	Vibrationen	Drehzahl verringern
Schneidenbruch	Werkstückstabilität	Spannmittel überprüfen, ggf. anpassen
	Werkzeugstabilität	Wenn möglich kürzeste Ausführung wählen
	Gegenlaufräsen	Im Gleichlauf fräsen
	Falsche Schnittdaten	Schnittdaten an Bearbeitung anpassen
	Werkzeugverschleiß	Werkzeug rechtzeitig nachschärfen bzw. ersetzen
	Vibrationen	Drehzahl verringern
Extremer Flächenverschleiß	Falsche Schneidstoffwahl	Werkzeug aus geeignetem Schneidstoff wählen
	Zerspanungstemperatur zu hoch	Schnittgeschwindigkeit reduzieren
Zu kurze Standzeit	Fräser falsch hinterschleifen	Fräser richtig nachschleifen bzw. schärfen
	Falsche Fräser	Fräser an Material anpassen
	Spanwinkel nicht korrekt	Fräser mit richtigem Spanwinkel wählen
	Reibung zu stark	Beschichtetes Werkzeug einsetzen
Gefräste Nut zu klein	Werkzeugverschleiß zu hoch	Werkzeug rechtzeitig nachschärfen bzw. ersetzen
Gefräste Nut zu groß	Werkzeuggrundlauffehler	Rundlauffehler minimieren
Vibration am Werkstück	Instabile Werkstückspannung	Für stabile Werkstückspannung sorgen
Vibration am Fräser	Nutenlänge zu groß	Wenn möglich kürzeste Ausführung wählen
	Werkzeug zu lang	Wenn möglich kürzeste Ausführung wählen
	Werkzeug zu labil	Stärkeren Schaft verwenden
	Vorschub zu niedrig	Vorschub erhöhen
	Schnittgeschwindigkeit zu niedrig	Schnittgeschwindigkeit erhöhen
	Instabile Werkzeugspannung	Für stabile Werkzeugspannung sorgen Spannmittel überprüfen bzw. austauschen



PROBLEMLÖSUNGEN SÄGEN

PROBLEM	URSACHE	LÖSUNGSMÖGLICHKEIT
Verkleben und Verkleben am Sägeblatt	Kühlschmiermittelzusammensetzung nicht korrekt	Für korrekte Kühlschmiermittelzusammensetzung sorgen
	Kühlschmiermittelzufuhr nicht ausreichend	Für ausreichende Kühlschmiermittezufuhr sorgen
	Falscher Vorschub	Vorschub an Material anpassen
Zähne brechen aus	Instabile Werkstückspannung	Für stabile Werkstückspannung sorgen
	Schlechte Spanräumung	Grobere Zahnteilung wählen
	Zähne verhaken im Material	Feinere Zahnteilung wählen
Kreissägeblattbruch	Falscher Ansatz beim Anschnitt	Kreissägeblatt muss bereits vor Materialkontakt laufen
	Stumpfes Kreissägeblatt	Werkzeug rechtzeitig nachschleifen bzw. ersetzen
Zu hoher Verschleiß	Kühlschmiermittelzusammensetzung nicht korrekt	Für korrekte Kühlschmiermittelzusammensetzung sorgen
	Kühlschmiermittelzufuhr nicht ausreichend	Für ausreichende Kühlschmiermittelzufuhr sorgen
	Schnitt unsauber	Feinere Zahnteilung wählen und Schnittdruck verringern
	Zähne setzen sich zu, Spanüberfüllung am Spangrund	Grobere Zahnteilung wählen



KERNLOCHTABELLEN

M

M	STEIGUNG	GEWINDEBOHRER	GEWINDEFORMER
1	0,25	0,75	0,9
1,1	0,25	0,85	1
1,2	0,25	0,95	1,1
1,4	0,3	1,1	1,25
1,6	0,35	1,25	1,65
1,8	0,35	1,45	1,65
2	0,4	1,6	1,85
2,2	0,45	1,75	2
2,5	0,45	2,05	2,3
3	0,5	2,5	2,8
3,5	0,6	2,9	3,25
4	0,7	3,3	3,7
4,5	0,75	3,7	
5	0,8	4,2	4,65
6	1	5	5,55
7	1	6	
8	1,25	6,8	7,4
9	1,25	7,8	
10	1,5	8,5	9,3
11	1,5	9,5	
12	1,75	10,2	11,2
14	2	12	13,1
16	2	14	15,1
18	2,5	15,5	16,9
20	2,5	17,5	18,9
22	2,5	19,5	
24	3	21	
27	3	24	
30	3,5	26,5	
33	3,5	29,5	
36	4	32	
39	4	35	
42	4,5	37,5	
45	4,5	40,5	
48	5	43	
52	5	47	
56	5,5	50,5	
60	5,5	54,5	
64	6	58	
68	6	62	

MF

MF	STEIGUNG	GEWINDEBOHRER	GEWINDEFORMER
2	0,25	1,75	
2,2	0,25	1,95	
2,3	0,25	2,05	
2,5	0,35	2,15	
2,6	0,35	2,2	
3	0,35	2,65	
3,5	0,35	3,15	
4	0,35	3,65	
4	0,5	3,5	3,8
5	0,5	4,5	4,8
6	0,5	5,5	5,8
6	0,75	5,2	5,65
7	0,75	6,2	
8	0,5	7,5	
8	0,75	7,2	7,65
8	1	7	7,55
9	0,75	8,2	
9	1	8	
10	0,5	9,5	
10	0,75	9,2	
10	1	9	9,55
10	1,25	8,8	
11	1	1	
12	0,75	11,2	
12	1	11	11,55
12	1,25	10,8	
12	1,5	10,5	11,35
13	1	12	
14	1	13	
14	1,25	12,8	
14	1,5	12,5	13,35
15	1	14	
15	1,5	13,5	
16	1	15	15,55
16	1,5	14,5	15,35
18	1	17	17,55
18	1,5	16,5	17,35
18	2	16	
20	1	19	19,55
20	1,5	18,5	19,35
20	2	18	
22	1	21	
22	1,5	20,5	21,35
22	2	20	
24	1	23	
24	1,5	22,5	23,35
24	2	22	
25	1,5	23,5	
26	1,5	24,5	25,35
27	1,5	25,5	
27	2	24	



KERNLOCHTABELLEN

MF

MF	STEIGUNG	GEWINDEBOHRER	GEWINDEFORMER
28	1,5	26,5	27,35
28	2	26	
30	1	29	
30	1,5	28,5	29,35
30	2	28	
32	1,5	30,5	
33	1,5	31,5	
33	2	31	
34	1,5	32,5	
34	1,5	32,5	
35	1,5	33,5	
36	1,5	34,5	
36	2	34	
36	3	33	

G

G	STEIGUNG	GEWINDEBOHRER	GEWINDEFORMER
0.12	28	8,8	9,25
0.25	19	11,8	12,55
0.38	19	15,25	16,05
0.50	14	19	20,05
0.62	14	21	
0.75	14	24,5	
0.88	14	28,25	
1.00	11	30,75	
1.12	11	35,5	
1.25	11	39,5	
1.75	11		
1.50	11	45,25	
1.75	11	51	
2.00	11	57	
2.25	11	63,1	
2.50	11	72,6	
2.75	11	78,9	
3.00	11	85,3	
3.25	11	91,5	
3.50	11	97,7	
3.75	11	104	
4	11	110,4	

UNC

UNC	STEIGUNG	GEWINDEBOHRER	GEWINDEFORMER
1 bis 64	1,55	1 1/2 bis 6	34
2 bis 56	1,85	1 3/4 bis 5	39,5
3 bis 48	2,1	2 bis 4 1/2	45
4 bis 40	2,35	2 1/4 bis 4 1/2	51,5
5 bis 40	2,65	2 1/2 bis 4	57,25
6 bis 32	2,85	2 3/4 bis 4	63,5
8 bis 32	3,5	3 bis 4	70
10 bis 24	3,9	3 1/4 bis 4	76,2
12 bis 24	4,5	3 1/2 bis 4	82,6
1/4 bis 20	5,1	3 3/4 bis 4	88,9
5/16 bis 18	6,6	4 bis 4	95,25
3/8 bis 16	8		
7/16 bis 14	9,4		
1/2 bis 13	10,8		
9/16 bis 12	12,2		
5/8 bis 11	13,5		
3/4 bis 10	16,5		
7/8 bis 9	19,5		
1 bis 8	22,25		
1 1/8 bis 7	25		
1 1/4 bis 7	28		
1 3/8 bis 6	30,75		

UNF

UNF	GEWINDEBOHRER
0-80	1,25
1 bis 72	1,55
2 bis 64	1,85
3 bis 56	2,15
4 bis 48	2,4
5 bis 44	2,7
6 bis 40	2,95
8 bis 36	3,5
10 bis 32	4,1
12 bis 28	4,6
1/4 bis 28	5,5
5/16 bis 24	6,9
3/8 bis 24	8,5
7/16 bis 20	9,9
1/2 bis 20	11,5
9/16 bis 18	12,9
5/8 bis 18	14,5
3/4 bis 16	17,5
7/8 bis 14	20,4
1 bis 12	23,25
1 1/8 bis 12	26,5
1 1/4 bis 12	29,5
1 1/3 bis 12	32,75
1 1/2 bis 12	36



PASSUNG NACH DURCHMESSER

Ø	PASSUNGEN										
0,95	ZB8	ZB9									
0,96	Z10	ZA7									
0,97	X8	X9	Z7	Z8							
0,98	K8	S6	S7	U7							
0,99	M8	N6	N7	N8	P6	P7	P8	K8			
1,00	H5	H6	J6	J7	J8	JS7	JS8	JS9			
1,01	F7	F8	G7	H8							
1,02	D7	E7	E8	EF8	F9	H10					
1,03	D8	E9									
1,04	CD7	CD7	D10	H11							
1,06	D11	H12									
1,07	C8	C9									
1,08	C10	D12									
1,09	H13										
1,10	C11										
1,95	ZB8	ZB9									
1,96	Z10	ZA7									
1,97	X8	X9	Z7	Z8							
1,98	S6	DS7	U6	U7							
1,99	K8	K8	M8N6	N7	N8	P6	P7	P8			
2,00	H5	H6	J6	J7	J8	JS7	JS8	JS9			
2,01	F7	F8	G7	H8							
2,02	D7	E7	E8	EF8	F9	H10					
2,03	D8	E9									
2,04	CD7	D10	H10								
2,06	D11	H12									
2,07	C8	C9									
2,08	C10	D12									
2,09	H13										
2,10	C11										
2,95	ZB8	ZB9									
2,96	Z10	ZA7									
2,97	X8	X9	Z7	Z8							
2,98	S6	S7	U6	U7							
2,99	K8	M8	N6	N7	N8	P6	P7	P8			
3,00	H5	H6	J6	J7	J8	JS7	JS8	JS9			
3,01	F7	F8	G7	G8							
3,02	D7	E7	E8	EF8	F9	H10					
3,03	D8	E9									
3,04	CD7	D10	H11								
3,06	D11	H12									
3,07	C8	C9									
3,08	C10	D12									
3,09	H13										
3,10	C11										
3,94	ZB8	ZB9									
3,95	Z9	Z10									
3,96	X9	Z7	Z8	ZA7							
3,97	X7										
3,98	P8	S6	S7								
3,99	M6	M8	N6	N7	N8						



PASSUNG NACH DURCHMESSER

Ø	PASSUNGEN											
4,00	H5	H6	J6	J7	J8	JS7	JS8	JS9	K6	K7	K8	
4,01	G6	G7	H8									
4,02	F8	H9										
4,03	D8	EF8	F9	H10								
4,04	D7	D8	E9	F10								
4,05	CD7	D9	H11									
4,06	D10											
4,08	C8	D11	H12									
4,09	C9											
4,10	D12											
4,94	ZB8	ZB9										
4,95	Z9	Z10										
4,96	X9	Z7	Z8	ZA7								
4,97	X7											
4,98	P8	S6	S7									
4,99	M6	M8	N6	N7	N8							
5,00	H5	H6	J6	J7	J8	JS7	JS8	JS9	K6	K7	K8	
5,01	G6	G7	H8									
5,02	F8	H9										
5,03	E8	EF8	F9	H10								
5,04	D7	D8	E9	F10								
5,05	CD7	D9	H11									
5,06	D10											
5,08	C8	D11	H12									
5,09	C9											
5,10	D12											
5,94	ZB8	ZB9										
5,95	Z9	ZB9										
5,96	X9	Z7	Z8	ZA7								
5,97	X7											
5,98	P8	S6	S7									
5,99	M6	M8	N6	N7	N8							
6,00	H5	H6	J6	J7	J8	JS7	JS8	JS9	K6	K7	K8	
6,01	G6	G7	H8									
6,02	F8	H9										
6,03	E8	EF8	F9	H10								
6,04	D7	D8	E9	F10								
6,05	CD7	D9	H11									
6,06	D10											
6,08	C8	D11	H12									
6,09	C9											
6,10	D12											
6,92	ZB9											
6,94	Z10	ZA7	ZA8									
6,95	X9	Z7	Z8									
6,96	X8											
6,97	U6	U7										
6,98	R6	R7										
6,99	M6	M7	M8	N7	N8							
7,00	H5	H6	J6	J7	J8	JS7	JS8	K7	K8			
7,01	G6	G7	H7	H8								



PASSUNG NACH DURCHMESSER

Ø	PASSUNGEN										
7,02	F7	H9									
7,03	E7	EF8	F8								
7,04	E8	H10									
7,05	D7	D8	E9	F10							
7,06	CD7	D9	H11								
7,08	D10										
7,09	C8										
7,10	C9	D11	H12								
7,92	ZB9										
7,94	Z10	ZA7	ZA8								
7,95	X9	Z7	Z8								
7,96	X8										
7,97	U6	U7									
7,98	R6	R7									
7,99	M6	M7	M8	N7	N8						
8,00	H5	H6	J6	J7	J8	JS7	JS8	K7	K8		
8,01	G6	G7	H7	H8							
8,02	F7	H9									
8,03	E7	EF8	F8								
8,04	E8	H10									
8,05	D7	D8	E9	F10							
8,06	CD7	D9	H11								
8,07											
8,08	D10										
8,09	C8										
8,10	C9	D11	H12								
8,92	ZB9										
8,94	Z10	ZA7	ZA8								
8,95	X9	Z7	Z8								
8,96	X8	U6	U7								
8,97	U6	U7									
8,98	R6	R7									
8,99	M6	M7	M8	N7	N8						
9,00	H5	H6	J6	J7	J8	JS7	JS8	K7	K8		
9,01	G6	G7	H7	H8							
9,02	D10	F7	H9								
9,03	E7	EF8	F8								
9,04	E8	H10									
9,05	D7	D8	E9	F10							
9,06	CD7	D9	H11								
9,07											
9,08											
9,09	C8										
9,10	C9	D11	H12								
9,92	ZB9										
9,94	Z10	ZA7	ZA8								
9,95	X9	Z7	Z8								
9,96	U6										
9,97	U6	U7									
9,98	R6	R7									
9,99	M6	M7	M8	N7	N8						



PASSUNG NACH DURCHMESSER

Ø	PASSUNGEN										
11,00	H5	H6	J6	J7	J8	JS7	JS8	K7	K8		
11,01	G6	G7	H7								
11,02	F7	H8	H9								
11,03	E7	EF8	F8								
11,04	E8	H10									
11,05	D7	D8	E9	F10							
11,06	CD7	D9	H11								
11,07											
11,08	D10										
11,09	C8										
11,10	C9	D10	H12								
11,90	ZB8	ZB9									
11,93	Z10	ZA8									
11,94	Z8										
11,95	X8	Z7									
11,96	X7										
11,97	P8	S6	S7								
11,98	P6	P7									
11,99	M6	M7	M8	N7	N8						
11,00	H5	J6	J7	J8	JS7	JS8	K7	K8			
11,01	G6	H7									
11,02	H8										
11,03	F8	H9									
11,04	E7	F9									
11,05	E8	H10									
11,06	D7	E9	F10								
11,07	H11										
11,08	D9										
11,09											
11,10	D10										
11,90	ZB8	ZB9									
11,93	Z10	ZA8									
11,94	Z8										
11,95	X8	Z7									
11,96	X7										
11,97	P8	S6	S7								
11,98	P6	P7									
11,99	M6	M8	N7	N8							



PASSUNG FORTLAUFEND

C8	C9	C10	C11	CD7	D7	D8	D9	D10	D11	D12	E7	E8	E9	EF8	F7	F8	F9	F10
1,07	1,07	1,09	1,10	1,04	1,02	1,03		1,04	1,06	1,08	1,02	1,02	1,03	1,02	1,01	1,01	1,02	
2,07	2,07	2,08	2,10	2,04	2,02	2,03		2,04	2,06	2,08	2,02	2,02	2,03	2,02	2,01	2,01	2,02	
3,07	3,07	3,08	3,10	3,04	3,02	3,03		3,04	3,06	3,08	3,02	3,02	3,03	3,02	3,01	3,01	3,02	
4,08	4,09			4,05	4,04	4,04	4,05	4,06	4,08	4,10		4,03	4,04	4,03		4,02	4,03	4,04
5,08	5,09			5,05	5,04	5,04	5,05	5,06	5,08	5,10		5,03	5,04	5,03		5,02	5,03	5,04
6,08	6,09			6,05	6,04	6,04	6,05	6,06	6,08	6,10		6,03	6,04	6,03		6,02	6,03	6,04
7,09	7,10			7,06	7,05	7,05	7,06	7,08	7,10		7,03	7,04	7,05	7,03	7,02	7,03		7,05
8,09	8,10			8,06	8,05	8,05	8,06	8,08	8,10		8,03	8,04	8,05	8,03	8,02	8,03		8,05
9,09	9,10			9,06	9,05	9,05	9,06	9,02	9,10		9,03	9,04	9,05	9,03	9,02	9,03		9,05
10,09	10,10			10,06	10,05	10,05	10,06	10,08	10,10		10,03	10,04	10,05	10,03	10,02	10,03		10,05
					11,06		11,08	11,10			11,04	11,05	11,06			10,03	11,04	11,06
					12,06		12,08	12,10			12,04	12,05	12,06			12,03	12,04	12,06

G6	G7	H5	H6	H7	H8	H9	H10	H11	H12	H13	J6	J7	J8	JS7	JS8	JS9	K6	K7
	1,01	1,00	1,00		1,01		1,02	1,04	1,06	1,09	1,00	1,00	1,00	1,00	1,00	1,00		
	2,01	2,00	2,00		2,01		2,02	2,04	2,06	2,09	2,00	2,00	2,00	2,00	2,00	2,00		
	3,01	3,00	3,00		3,01		3,02	3,04	3,06	3,09	3,00	3,00	3,00	3,00	3,00	3,00		
4,01	4,01	4,00	4,00		4,01	4,02	4,03	4,05	4,08		4,00	4,00	4,00	4,00	4,00	4,00	4,00	4,00
5,01	5,01	5,00	5,00		5,01	5,02	5,03	5,05	5,08		5,00	5,00	5,00	5,00	5,00	5,00	5,00	5,00
6,01	6,01	6,00	6,00		6,01	6,02	6,03	6,05	6,08		6,00	6,00	6,00	6,00	6,00	6,00	6,00	6,00
7,01	7,01	7,00	7,00	7,01	7,01	7,02	7,04	7,06	7,10		7,00	7,00	7,00	7,00	7,00			7,00
8,01	8,01	8,00	8,00	8,01	8,01	8,02	8,04	8,06	8,10		8,00	8,00	8,00	8,00	8,00			8,00
9,01	9,01	9,00	9,00	9,01	9,01	9,02	9,04	9,06	9,10		9,00	9,00	9,00	9,00	9,00			9,00
10,01	10,01	10,00	10,00	10,01	10,02	10,02	10,04	10,06	10,10		10,00	10,00	10,00	10,00	10,00			10,00
11,01		11,00		11,01	11,02	11,03	11,05	11,07			11,00	11,00	11,00	11,00	11,00			11,00
12,01		12,00		12,01	12,02	12,03	12,05	12,07			12,00	12,00	12,00	12,00	12,00			12,00





PASSUNG FORTLAUFEND

K8	M6	M7	M8	N6	N7	N8	P6	P7	P8	R6	R7	S6	S7	U6	U7	X7	X8	X9
0,99			0,99	0,99	0,99	0,99	0,99	0,99	0,99			0,98	0,98	0,98	0,98		0,97	0,97
1,99			1,99	1,99	1,99	1,99	1,99	1,99	1,99			1,98	1,98	1,98	1,98		1,97	1,97
2,99			2,99	2,99	2,99	2,99	2,99	2,99	2,99			2,98	2,98	2,98	2,98		2,97	2,97
4	3,99		3,99	3,99	3,99	3,99			3,98			3,98	3,98			3,97		3,96
5	4,99		4,99	4,99	4,99	4,99			4,98			4,98	4,98			4,97		4,96
6	5,99		5,99	5,99	5,99	5,99			5,98			5,99	5,99			5,97		5,96
7	6,99	6,99	6,99		6,99	6,99				6,98	6,98			6,97	6,97		6,96	6,95
8	7,99	7,99	7,99		7,99	7,99				7,98	7,98			7,97	7,97		7,96	7,95
9	8,99	8,99	8,99		8,99	8,99				8,98	8,98			8,97	8,97		8,96	8,95
10	9,99	9,99	9,99		9,99	9,99				9,98	9,98			9,97	9,97		9,96	9,95
11	10,99	10,99	10,99		10,99	10,99	10,98	10,98	10,97			10,97	10,97			10,96	10,95	
12	11,99		11,99		11,99	11,99	11,98	11,98	11,97			10,97	10,97			11,96	11,95	

Z7	Z8	Z9	Z10	ZA7	ZA8	ZA9	ZB8	ZB9										
0,97	0,97		0,96	0,96			0,95	0,95										
1,97	1,97		1,96	1,96			1,95	1,95										
2,97	2,97		2,96	2,96			2,95	2,95										
3,96	3,96	3,95	3,95	3,95			3,94	3,94										
4,96	4,96	4,95	4,95	4,95			4,94	4,94										
5,96	5,96	5,95	5,95	5,95			5,94	5,94										
6,96	6,95		6,94	6,94	6,94			6,92										
7,95	7,95		7,94	7,94	7,94			7,92										
8,95	8,95		8,94	8,94	8,94			8,92										
9,95	9,95		9,94	9,94	9,94			9,92										
10,95	10,94		10,93		10,93			10,9	10,9									
11,95	11,94		11,93		11,93			11,9	11,9									





UMRECHNUNGSTABELLE HÄRTE

ZUGFESTIGKEIT	VICKERSHÄRTE	BRINELLHÄRTE	ROCKWELLHÄRTE							
			HRB	HRF	HRC	HRA	HRD	HR15N	HR30N	HR45N
255	80	76								
270	85	80,7								
285	90	85,5								
305	95	90,2								
320	100	95								
335	105	99,8								
350	110	105								
370	115	109								
385	120	114								
400	1225	119								
415	130	124								
430	135	128								
450	140	133								
465	145	138								
480	150	143								
495	155	147								
510	160	152								
530	165	156								
545	170	162								
560	175	166								
575	180	171								
595	185	176								
610	190	181								
625	195	185								
640	200	190	91,5	110,1						
660	205	195	92,5							
675	210	199	93,5	111,3						
690	215	204	95	112,4						
705	220	209	95	112,4						
720	225	214	96							
740	230	219	96,7	113,4						
755	235	223								
770	240	228	98,1	114,3	20,3	60,7	40,3	63,6	41,7	19,9
785	245	233			21,3	61,2	41,1	70,1	42,5	21,1
800	250	238	99,5	115,1	22,2	61,6	41,7	70,6	43,4	22,2
820	255	242			23,1	62	42,2	71,1	44,2	23,2
835	260	247	101		24	62,4	43,1	71,6	45	24,3
850	265	252			24,8	62,7	43,7	72,1	45,7	25,2
865	270	257	102		25,6	63,1	44,3	72,6	46,4	26,2
880	275	261			26,4	63,5	44,9	73	47,2	27,1
900	280	266	104		27,1	63,8	45,3	73,4	47,8	27,9
915	285	271			27,8	64,2	46	73,8	48,4	28,7
930	290	276	105		28,5	64,5	46,5	74,2	49	29,5
950	295	280			29,2	64,8	47,1	74,6	49,7	30,4
965	300	285			29,8	65,2	47,5	74,9	50,2	31,1
995	310	295			31	65,8	48,4	75,6	51,3	32,5
1030	320	304			32,2	66,4	49,4	76,2	52,3	33,9
1060	330	314			33,3	67	50,2	76,8	53,6	35,2
1095	340	323			34,4	67,6	51,1	77,4	54,4	36,5
1125	350	333			35,5	68,1	51,9	78	55,4	36,5



UMRECHNUNGSTABELLE HÄRTE

ZUGFESTIGKEIT	VICKERSHÄRTE	BRINELLHÄRTE	ROCKWELLHÄRTE							
			HRB	HRF	HRC	HRA	HRD	HR15N	HR30N	HR45N
1155	360	342			36,6	68,7	52,8	76,6	56,4	39,1
1190	370	352			37,7	69,2	53,6	79,2	57,4	40,4
1220	380	361			38,8	69,8	54,4	79,8	58,4	41,7
1255	390	371			39,8	70,3	55,3	80,3	59,3	42,9
1290	400	380			40,8	70,8	56	80,8	60,2	44,1
1320	410	390			41,8	71,4	56,8	81,4	61,1	45,3
1350	420	399			42,7	71,8	57,5	81,8	61,9	46,4
1385	430	409			43,6	72,3	58,2	82,3	63,7	47,4
1420	440	418			44,5	72,8	58,8	82,8	63,5	49,4
1485	460	437			46,1	73,6	60,1	83,6	64,9	50,4
1520	470	447			46,9	74,1	60,7	83,9	65,7	51,3
1555	480	456			47,7	74,5	61,3	84,3	66,4	52,2
1595	490	466			48,4	74,9	61,6	84,7	67,1	53,1
1630	500	475			49,1	75,3	62,2	85	67,7	53,9
1665	510	485			49,8	75,7	62,9	85,4	68,3	54,7
1700	520	494			50,5	76,1	63,5	85,7	69	55,6
1740	530	504			51,1	76,7	64,4	86,3	70	57
1810	550	523			52,3	77	64,8	86,6	70,5	57,8
1845	560	532			53	77,4	65,4	86,9	71,2	58,6
1880	570	542			53,6	77,8	65,8	87,2	71,7	59,3
1920	580	551			54,1	78	66,2	87,5	72,1	59,9
1955	590	561			54,7	78,4	66,7	87,8	72,7	60,5
1995	600	570			55,2	78,6	67	88	73,2	61,2
2030	610	580			55,7	78,9	67,5	88,2	73,7	61,7
2070	620	589			56,3	79,2	67,9	88,5	74,2	62,4
2105	630	599			56,8	79,5	68,3	88,8	74,6	63
2145	640	608			57,3	79,8	68,7	89	75,1	63,5
2189	650	619			57,8	80	69	89,2	75,5	64,1
	660				58,3	80,3	69,4	89,5	75,9	64,7
	670				58,8	80,6	69,8	89,7	76,4	65,3
	680				59,2	80,8	70	89,8	76,8	65,7
	690				59,7	81,1	70,5	90,1	77,2	66,2
	700				60,1	81,3	70,8	90,3	77,6	66,7
	720				61	81,8	71,5	90,7	78,4	67,7
	740				61,8	82,2	72,1	91	79,1	68,6
	760				62,5	82,6	72,6	91,2	79,7	69,4
	780				63,3	83	73,3	91,5	80,4	70,2
	800				64	83,4	73,8	91,8	81,1	71
	820				64,7	83,8	74,3	92,1	81,7	71,8
	840				65,3	84,1	74,8	92,3	82,2	72,2
	860				65,9	84,4	75,3	92,5	82,7	73,1
	880				66,4	84,7	75,7	92,7	83,1	73,6
	900				67	85	76,1	92,9	83,6	74,2



HALLAS TOOLS



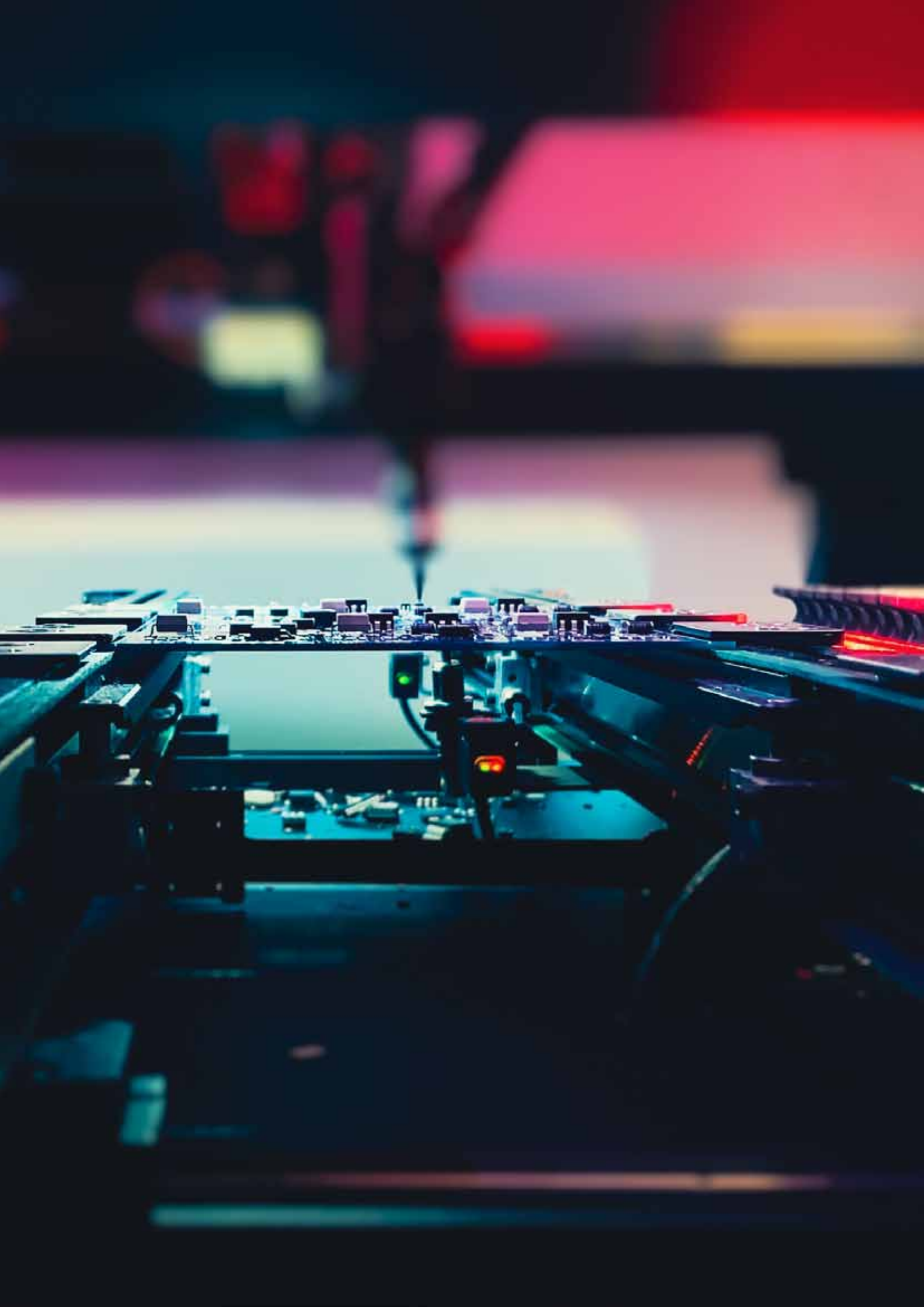



ALLGEMEINE GESCHÄFTS- UND LIEFERBEDINGUNGEN

§ 1 Allgemeines

(1) Für alle Lieferungen und sonstigen Leistungen gelten ausschließlich die nachstehenden Verkaufs- und Lieferbedingungen; sie gelten nur gegenüber Unternehmern im Sinne von § 310 Abs. 1 i.V.m. § 14 Bürgerliches Gesetzbuch. Sie gelten für alle zukünftigen Verträge und Aufträge als vereinbart, ohne dass bei späteren Vertragsabschlüssen ausdrückliche Hinweise erforderlich wären. Dies gilt insbesondere für Auslieferungen, Reparaturen telefonisch, schriftlich oder elektronisch erteilte Aufträge.

(2) Abweichende Bedingungen des Käufers, die der Verkäufer nicht ausdrücklich anerkennt, sind unverbindlich, auch wenn der Verkäufer ihnen nicht ausdrücklich widerspricht.

(3) Einbeziehung und Auslegung dieser Verkaufs- und Lieferbedingungen regeln sich ebenso wie Abschluss und Auslegung der Rechtsgeschäfte mit dem Käufer selbst ausschließlich nach dem Recht der Bundesrepublik Deutschland. Die Anwendung des einheitlichen Gesetzes über den Abschluss von internationalen Kaufverträgen über bewegliche Sachen, des einheitlichen Gesetzes über den internationalen Kauf beweglicher Sachen des UN-Kaufrechts sind ausgeschlossen.

(4) Die Unwirksamkeit einzelner Bestimmungen dieses Vertrags oder seiner Bestandteile lässt die Wirksamkeit der übrigen Regelungen unberührt. Die Vertragspartner sind im Rahmen des Zumutbaren nach Treu und Glauben verpflichtet, eine unwirksame Bestimmung durch eine ihrem wirtschaftlichen Erfolg gleichkommende wirksame Regelung zu ersetzen, sofern dadurch keine wesentliche Änderung des Vertragsinhaltes herbeigeführt wird; das Gleiche gilt, falls ein regelungsbedürftiger Sachverhalt nicht ausdrücklich geregelt ist.

(5) Erfüllungsort für alle sich mittelbar oder unmittelbar aus diesem Vertragsverhältnis ergebenden Verpflichtungen, einschließlich der Zahlungspflicht, ist der Sitz des Verkäufers.

(6) Gerichtsstand ist der für den Firmensitz des Verkäufers zuständige Gerichtsort (Amtsgericht / Landgericht Ingolstadt), soweit der Käufer Kaufmann ist. Der Verkäufer ist auch berechtigt, vor einem Gericht zu klagen, welches für den Sitz oder eine Niederlassung des Käufers zuständig ist.

§ 2 Angebote, Leistungsumfang und Vertragsabschluss

(1) Vertragsangebote des Verkäufers sind freibleibend.

(2) Für den Umfang der vertraglich geschuldeten Leistung ist ausschließlich die Auftragsbestätigung des Verkäufers maßgebend. Erst mit dieser kommt ein Vertrag zustande.

(3) Änderungen der Konstruktion, der Werkstoffwahl, der Spezifikation und der Bauart behält sich der Verkäufer auch nach Absendung einer Auftragsbestätigung vor, sofern diese Änderungen weder der Auftragsbestätigung noch der Spezifikation des Käufers widersprechen. Der Käufer wird sich darüber hinaus mit darüber hinausgehenden Änderungsvorschlägen des Verkäufers einverstanden erklären, soweit diese für den Käufer zumutbar sind.

(4) Teillieferungen sind zulässig.

(5) Die dem Angebot oder der Auftragsbestätigung zugrunde liegenden Unterlagen wie Abbildungen, Zeichnungen, Maß- und Gewichtsangaben sind in der Regel nur als Annäherungswerte zu verstehen, sofern sie nicht ausdrücklich als verbindlich bezeichnet werden.

§ 3 Preise und Zahlungsbedingungen

(1) Die Preise gelten ab Werk ausschließlich Verpackung und sonstiger Versand- und Transportspesen. Die Verpackung wird zu Selbstkosten berechnet und nur zurückgenommen, wenn der Verkäufer kraft zwingender gesetzlicher Regelung hierzu verpflichtet ist.

(2) Berücksichtigt der Verkäufer Änderungswünsche des Käufers, so werden die hierdurch entstehenden Mehrkosten dem Käufer in Rechnung gestellt.

(3) Bei schuldhafter Überschreitung der Zahlungsfrist werden unter Vorbehalt der Geltendmachung weitergehender Ansprüche Zinsen in Höhe von 8 % über dem jeweils geltenden Basiszinssatz verlangt.

§ 4 Aufrechnung und Zurückhaltung

Aufrechnung und Zurückhaltung sind ausgeschlossen, es sei denn, dass die Aufrechnungsforderung unbestritten oder rechtskräftig festgestellt ist.

§ 5 Lieferfrist

Die Angabe eines Lieferzeitpunktes erfolgt nach bestem Ermessen und verlängert sich angemessen, wenn der Käufer seinerseits erforderliche oder vereinbarte Mitwirkungshandlungen verzögert oder unterlässt oder Zusatzaufträge erteilt. Das Gleiche gilt bei Maßnahmen im Rahmen von Arbeitskämpfen, insbesondere Streik und Aussperrung sowie beim Eintritt unvorhergesehener Hindernisse, die außerhalb des Willens des Verkäufers liegen, z.B. Lieferverzögerung eines Vorlieferanten, Verkehrs- und Betriebsstörungen, Werkstoffoder Energiemangel etc. Auch vom Käufer veranlasste Änderungen der gelieferten Waren führen zu einer angemessenen Verlängerung der Lieferfrist.

§ 6 Gefahrübergang

Die Gefahr geht auf den Käufer über, sobald der Verkäufer die Ware einem Transportunternehmen übergeben hat. Alle Sendungen, auch Rücksendungen reisen ausnahmslos auf Risiko der Käufers.

§ 7 Eigentumsvorbehalt

(1) Der Verkäufer behält sich das Eigentum an den gelieferten Waren bis zur vollständigen Bezahlung vor. Der Eigentumsvorbehalt gilt auch, bis sämtliche, auch künftige und bedingte Forderungen aus der Geschäftsverbindung, zwischen Käufer und Verkäufer erfüllt sind.

(2) Der Käufer ist zur Sicherungsübereignung oder Verpfändung der Ware nicht befugt, jedoch zur weiteren Veräußerung der Vorbehaltsware im geordneten Geschäftsgang berechtigt. Die hieraus gegenüber seinen Geschäftspartnern entstehenden Forderungen tritt er hiermit dem Verkäufer bereits ab und teilt dies dem Verkäufer auf dessen Verlangen auch mit.

(3) Wird die Ware vom Käufer be- oder verarbeitet, erstreckt sich der Eigentumsvorbehalt auch auf die gesamte neue Sache. Der Käufer erwirbt Miteigentum zu dem Bruchteil, der dem Verhältnis des Wertes seiner Ware zu dem der vom Verkäufer gelieferten Ware entspricht.

(4) Übersteigt der Wert sämtlicher für den Verkäufer bestehenden Sicherheiten die bestehenden Forderungen nachhaltig um mehr als 10 %, so wird der Verkäufer auf Verlangen des Käufers Sicherheiten nach Wahl des Verkäufers freigeben.

(5) Der Verkäufer ist berechtigt, die Eigentumsvorbehaltsrechte geltend zu machen, ohne vom Vertrag zurückzutreten.

§ 8 Mängelansprüche

(1) Ist der Kauf für beide Teile ein Handelsgeschäft, so hat der Käufer die Ware unverzüglich nach Erhalt, soweit dies nach ordnungsgemäßem Geschäftsgang tunlich ist, zu untersuchen, und, wenn sich ein Mangel zeigt, dem Verkäufer unverzüglich Anzeige zu machen. Unterlässt der Käufer diese Anzeige, so gilt die Ware als genehmigt, es sei denn, dass es sich um einen Mangel handelt, der bei der Untersuchung nicht erkennbar war. Im Übrigen gelten die §§ 377 ff. HGB.

(2) Die Mängelansprüche sind auf Nacherfüllung beschränkt. Bei Fehlschlagen der Nacherfüllung hat der Käufer das Recht, nach seiner Wahl Herabsetzung der Vergütung oder Rückgängigmachung des Vertrages zu verlangen.

(3) Weitergehende Ansprüche des Käufers, soweit diese nicht aus einer Garantieübernahme resultieren, sind ausgeschlossen. Dies gilt nicht bei Vorsatz, grober Fahrlässigkeit oder Verletzung wesentlicher Vertragspflichten des Verkäufers.

(4) Die Mängelansprüche verjähren in einem Jahr seit Lieferung der Kaufsache und sind bei Lieferung gebrauchter Sachen ausgeschlossen.

§ 9 Haftung

Schadensersatzansprüche des Käufers sind ausgeschlossen. Dies gilt nicht bei Vorsatz, grober Fahrlässigkeit, Verletzung wesentlicher Vertragspflichten des Verkäufers oder Garantieübernahmen.



**HALLAS TOOLS GMBH
LINSENÄCKER 18
WERK 2
72379 HECHINGEN**

**TELEFON 07471/9429530
MOBIL 0170/3441726**

**EMAIL MH@HALLAS-TOOLS.DE
WWW.HALLAS-TOOLS.DE**